



# BEVERAGE-AIR

3779 Champion Blvd., Winston-Salem, NC 27105  
1-888-845-9800 Fax# 1-336-245-6453  
<http://www.Beverage-Air.com>

## Commercial Refrigeration Equipment General Specification

### 3 Year Parts/Labor Warranty Additional 2 Year Compressor Warranty

#### WTR SERIES WORKTOP UNITS

Versatile, compact (29" deep) models with stainless steel work tops and refrigerated storage of food products. Working height is 35 1/2."

#### CABINET CONSTRUCTION

Heavy duty construction includes stainless steel on front, sides, door(s) and grille. Stainless steel 2 1/2" thick worktop with 4" high removable backsplash. Cabinet back and bottom are galvanized steel. Interior liner is made of aluminum for longer lasting corrosion protection. Interior thermometer is standard.

Cabinets are insulated with foamed-in-place polyurethane insulation of 2" minimum thickness. Doors are mounted to cabinet on self-closing, cartridge style hinges with 120° stay open feature. A plug-in type vinyl magnetic gasket is attached to each door for positive seal. Convenient, contoured, pull handle is made of black anodized aluminum. Interior arrangement includes 2 steel wire epoxy coated shelves behind each door, adjustable in 1/2 inch increments. Interior light with manual switch is provided with glass door models.

#### REFRIGERATION

Refrigeration system utilizes R134a refrigerant metered by a capillary tube system. Automatic (non-electric) condensate evaporator is standard. Interior forced air system, with high humidity evaporator coils, provides the ideal environment for food preservation.

#### ELECTRICAL

Units wired at factory and ready for connection to a 115/60/1 phase, 15 amp dedicated outlet. 8' long cord and plug set included.

#### SPECIAL FEATURES

- WTR27A & WTR48A have earned the ENERGY STAR®.
- Cartridge style door hinges provides positive seal & eliminates door sagging issues (excludes glass door and some special units).
- 6" casters, two with brakes standard.
- Optional 6" legs or 3" casters available

**\*Note:** Overall heights of casters may vary with different types of casters depending upon caster manufacturer designations.

Item No. \_\_\_\_\_  
Quantity \_\_\_\_\_

## WORK TOP REFRIGERATORS 29" BASE MODEL SERIES

**MODELS:**  
WTR27A  
WTR48A  
WTR60A  
WTR72A



WTR27



WTR48



WTR60

#### ELECTRICAL CONNECTION

Units pre-wired at factory and include 8' long cord and plug



115/60/1  
NEMA-5-15P

Available From:



**\*Note:** Not all markings may apply to all model variations.

Model Specified \_\_\_\_\_

Store# \_\_\_\_\_

Location \_\_\_\_\_

Quantity \_\_\_\_\_



**BEVERAGE-AIR**

**Standard Worktop Refrigerator Cabinets**

Models: WTR27A, WTR48A, WTR60A, WTR72A

MODEL	WTR27A	WTR48A	WTR60A	WTR72A
<b>EXTERNAL DIMENSIONAL DATA</b>				
Length Overall (inches)	27"	48"	60"	72"
Length Overall (mm)	686	1219	1524	1829
Depth Overall (inches) - Less handle	29 1/4"	29 1/4"	29 1/4"	29 1/4"
Depth Overall (mm) - Less handle	743	743	743	743
Height Overall—on 6" casters (inches)*	39 1/2"	39 1/2"	39 1/2"	39 1/2"
Height Overall—on 6" casters (mm)*	1003	1003	1003	1003
Depth with Door Open 90°	55 1/4"	52 1/4"	53 13/16"	52 1/8"
Clear Door Opening (inches)	22 1/2" x 23 1/4"	19 1/2" x 21 1/2"	22 1/2" x 21 3/8"	19 1/2" x 21 1/2"
Number of doors	1	2	2	3
<b>INTERNAL DIMENSIONAL DATA</b>				
NET Capacity (cubic ft.)	7.3	13.9	17.1	21.5
NET Capacity (Liters)	207	394	484	609
Internal Length Overall (inches)	23"	44"	56"	68"
Internal Length Overall (mm)	584	1118	1422	1727
Internal Depth Overall (inches)	20"	20"	24 7/8"	19 3/4"
Internal Depth Overall (mm)	508	508	632	502
Internal Height Overall (inches)	23"	23"	23"	22 3/4"
Internal Height Overall (mm)	584	584	584	578
Number of shelves	2	4	4	6
<b>ELECTRICAL DATA</b>				
Full Load Amperes 115/60/1	4.0	3.3	8.2	8.2
<b>ENERGY CONSUMPTION (KWH)</b>				
	2.88	2.37	3.76	3.38
<b>REFRIGERATION DATA</b>				
Horsepower	1/6	1/5	1/4	1/4
<b>WEIGHT DATA</b>				
Gross Weight (Crated lbs)	161	235	265	305
Gross Weight (Crated kg)	73	107	120	138

\*Note: Overall heights of casters may vary with different types of casters depending upon caster manufacturer designations.

**PLAN VIEWS**

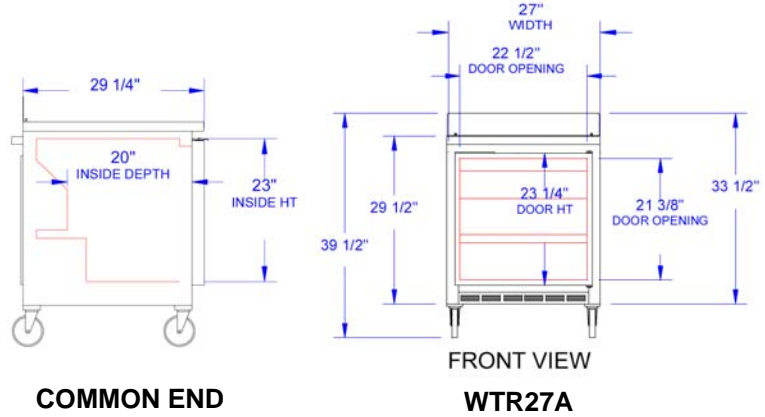

**COMMON END**

**WTR27A**

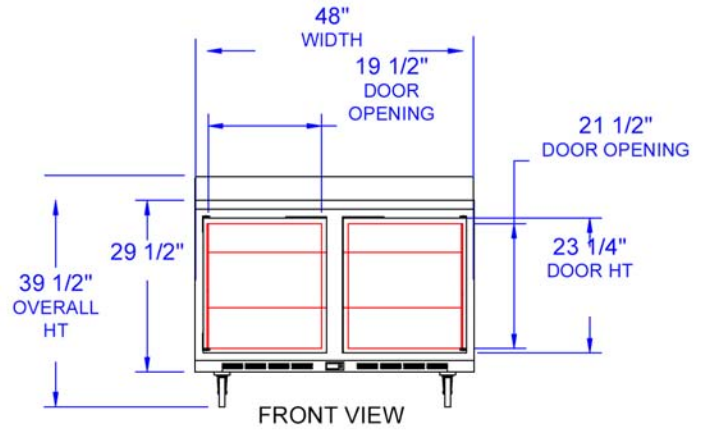

**WTR48A**

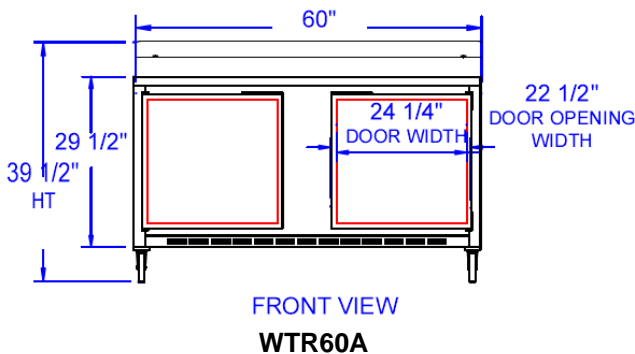

**FRONT VIEW**  
**WTR60A**

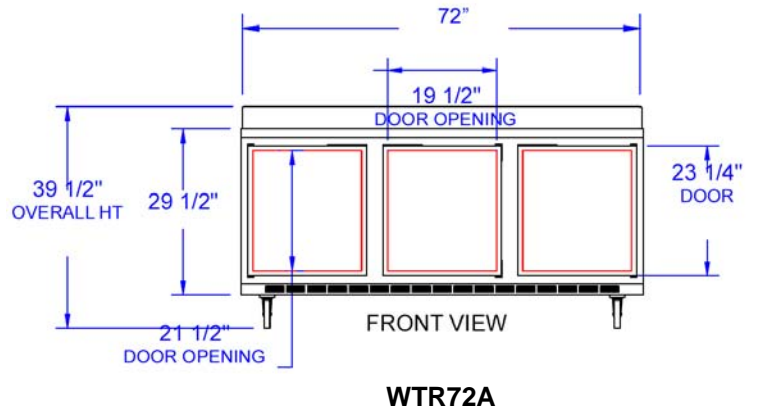

**FRONT VIEW**  
**WTR72A**

**BEVERAGE-AIR® CORPORATION**

3779 Champion Blvd. • Winston-Salem, NC 27105 USA • (336) 245-6400 • Fax (336) 245-6453 • (888) 845-9800 • www.beverage-air.com

Specifications are subject to change without prior notice. 06/13