



BEVERAGE-AIR

3779 Champion Blvd., Winston-Salem, NC 27105
1-888-845-9800 Fax# 1-336-245-6453
<http://www.Beverage-Air.com>

Item No. _____
Quantity _____

WORK TOP REFRIGERATOR FOOD PREPARATION SERIES

MODELS:
WTR36A

Commercial Refrigeration Equipment General Specification

3 Year Parts/Labor Warranty Additional 2 Year Compressor Warranty

WTR SERIES WORKTOP UNITS

Versatile, compact model with stainless steel work tops and refrigerated storage of food products. Working height is 35 5/8".

CABINET CONSTRUCTION

Heavy duty construction includes stainless steel on front, sides, doors and grille. Stainless steel 2 1/2" thick worktop with 4" high removable backsplash. Cabinet back and bottom are galvanized steel. Interior liner is made of aluminum for longer lasting corrosion protection. Interior thermometer is standard.

Cabinet is insulated with foamed-in-place polyurethane insulation of 2" minimum thickness. Doors are mounted to cabinet on self-closing, cartridge style hinges with 120° stay open feature. A plug-in type vinyl magnetic gasket is attached to each door for positive seal. Convenient, contoured, pull handle is made of black anodized aluminum. Interior arrangement includes 2 steel wire epoxy coated shelves behind each door, adjustable in 1/2 inch increments.

REFRIGERATION

Refrigeration system utilizes R134a refrigerant metered by a capillary tube system. Automatic (non-electric) condensate evaporator is standard. Interior forced air system, with high humidity evaporator coils, provides the ideal environment for food preservation.

ELECTRICAL

Units wired at factory and ready for connection to a 115/60/1 phase, 15 amp dedicated outlet. 8' long cord and plug set included.

SPECIAL FEATURES

- Cartridge style door hinges provides positive seal & eliminates door sagging issues (excludes glass door and some special units).
- 6" casters, two with brakes standard.
- Optional 6" legs or 3" casters available

***Note:** Overall heights of casters may vary with different types of casters depending upon caster manufacturer designations.



WTR36A

ELECTRICAL CONNECTION

Units pre-wired at factory and include 8' long cord and plug set.



Available From:



***Note:** Not all markings may apply to all model variations.

Model Specified _____

Store# _____

Location _____

Quantity _____



BEVERAGE-AIR

**Standard Worktop
Refrigerator Cabinets
Models: WTR36A**

MODEL	WTR36A
EXTERNAL DIMENSIONAL DATA	
Length Overall (inches)	36"
Length Overall (mm)	914
Depth Overall (inches) - Less handle	29 1/4"
Depth Overall (mm) - Less handle	743
Height Overall— on 6" casters (inches)*	39 1/2"
Height Overall—on 6" casters (mm)*	1003
Depth with Door Open 90 °	46 1/4"
Clear Door Opening (inches)	13 9/16" x 21 5/8"
Number of doors	2
INTERNAL DIMENSIONAL DATA	
NET Capacity (cubic ft.)	8.5
NET Capacity (Liters)	241
Internal Length Overall (inches)	32"
Internal Length Overall (mm)	813
Internal Depth Overall (inches)	20"
Internal Depth Overall (mm)	508
Internal Height Overall (inches)	23"
Internal Height Overall (mm)	584
Number of shelves	4
ELECTRICAL DATA	
Full Load Amperes 115/60/1	3.3
ENERGY CONSUMPTION (KWH)	
	N/A*
REFRIGERATION DATA	
Horsepower	1/5
WEIGHT DATA	
Gross Weight (Crated lbs)	210
Gross Weight (Crated kg)	95

PLAN VIEWS

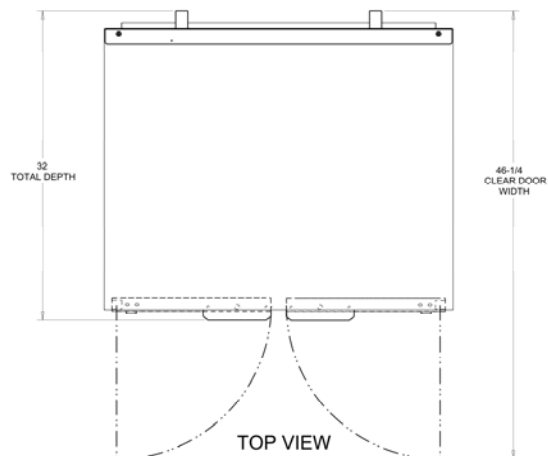
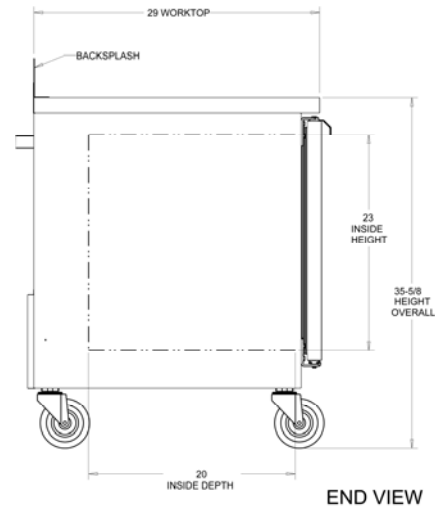
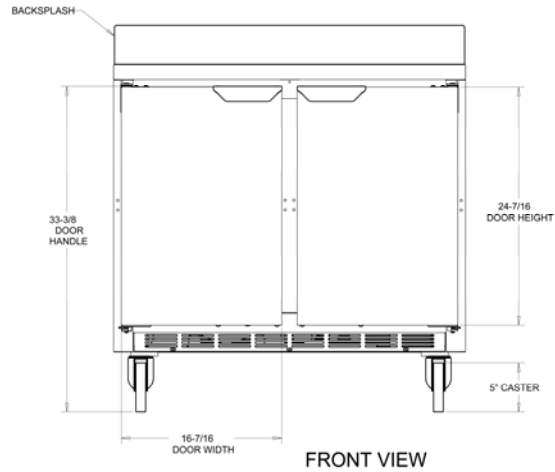

*Note: Overall heights of casters may vary with different types of casters depending upon caster manufacturer designations.



BEVERAGE-AIR® CORPORATION

3779 Champion Blvd. • Winston-Salem, NC 27105 USA • (336) 245-6400 • Fax (336) 245-6453 • (888) 845-9800 • www.beverage-air.com

Specifications are subject to change without prior notice. 06/13