



BCT-101E

BCT-101E

Single Electric
Combination-Oven/Steamer with
Touchscreen Control



Project _____

Item No. _____

Quantity _____

- Standard rack with 3.35" (85mm) spacing holds eight 12" x 20" x 2-1/2" deep North American hotel pans
- Optional rack with 2.56" (65mm) spacing holds ten 12" x 20" x 2" deep Gastronorm pans

Refer to operator manual specification chart for listed model names.

CONSTRUCTION

- 304 stainless steel exterior and interior
- Dual pane tempered viewing window with hinged inner glass for easy cleaning
- 2" (50mm) fixed drain in the bottom center of cavity
- Door mounted drip tray reduces the risk of wet, slippery floors
- Automatic door stops in positions of 110° and 180°
- Left hinge door is field convertible to the right side (with the purchase of conversion kit)
- Two step safety door latch. The first step stops the fan.

OPERATION

- Built in steam generator produces pure, dry steam
- Automatic boiler flushing system
- Easy to use touchscreen control
- Multiple cooking modes include hot air, CombiSmart, CombiOptima, retherm, steaming, low-temperature steaming, forced steaming, proofing, preheating
- Stores up to 500 recipes with up to 15 steps each
- Manual or automatic cooling
- Automatic humidity pulsing
- External core temperature probe
- Rack timing allows for setting individual timers for each rack
- Reversible 9 speed fan for optimum baking and roasting results
- USB port for data and recipe transfer
- HACCP recording and documentation
- Automated CombiWash, closed circuit cleaning system features very low water and detergent consumption and no contact with chemicals. No proprietary chemicals required, see owner's manual for detergent guidelines.
- Semi automatic deliming system

STANDARD FEATURES

- External core temperature probe with multiple measuring points
- 21-1/2" tall stainless steel stand with runners & adjustable feet
- Bright halogen lights for superior visibility
- Built in hand shower
- Removeable cleaning chemical bottle shelf
- Start-up inspection service by factory authorized service agent
- One year parts and labor oven warranty*

* For all international markets, contact your local distributor.



OPTIONS AND ACCESSORIES

(AT ADDITIONAL CHARGE)

■ Legs and Stands

- 21-1/2" tall stainless steel stand with runners & casters
- Adjustable feet for table top installation

■ Banqueting Accessories

- Pan cassette with 2.56" (65mm) spacing
- Pan cassette with 3.35" (85mm) spacing
- Plate cassette with 2.56" (65mm) spacing holds 20 plates
- Plate cassette with 3.35" (85mm) spacing holds 15 plates
- Cassette support platform
- Transport trolley, to move the cassette
- Insulated thermal blanket with vent

- Wire oven rack
- Right hinge door
- Extra year warranty

OPTIONS AND ACCESSORIES

(AT NO CHARGE)

- Optional rack with 2.56" (65mm) spacing

BLODGETT OVEN COMPANY

www.blodgett.com • 44 Lakeside Avenue, Burlington, VT 05401 • Phone: (802) 658-6600 • Fax: (802) 864-0183



BCT-101E

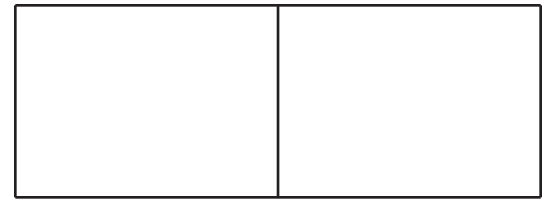

APPROVAL/STAMP

DIMENSIONS ARE IN INCHES (MM)

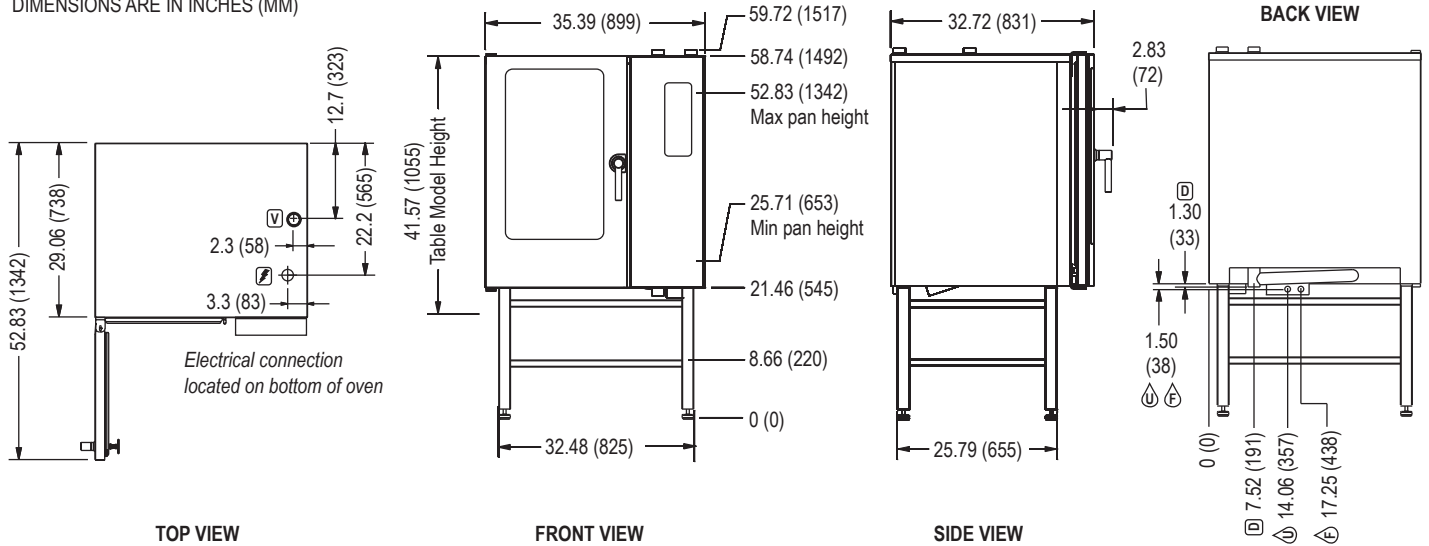

SHORT FORM SPECIFICATIONS: Provide Blodgett Combi model BCT-101E combination-oven/steamer. The BCT-101E has a 2 piece rack system with 3.35" (85mm) rack spacing that holds eight 12" x 20" x 2-1/2" deep North American hotel pans. The optional 2 piece rack system with 2.5" (65mm) spacing holds ten 12" x 20" x 2" deep Gastronorm pans. Unit shall have 304 stainless steel exterior and interior. Oven door shall have dual pane tempered viewing window with hinged inner glass for easy cleaning. Unit shall have the ability to cook with pressureless steam, hot air, or combination of steam and hot air. Steam generator shall be separate from the cooking compartment and shall drain and flush automatically. Multiple modes include hot air, combi with CombiOptima, retherming, steaming, low-temperature steaming, forced steaming, proofing, cooling, and preheating. Unit shall have bright halogen lights for superior visibility. Touchscreen control stores 500 recipes with 15 stages each, in addition to pre-programmed recipes. External core temperature probe, rack timing allows for setting individual timers for each rack, HACCP quality control, USB connectivity, automatic service diagnosis. The reversible 9 speed fan provides optimum baking and roasting results. Automated CombiWash, closed circuit cleaning system features very low water and detergent consumption and no contact with chemicals. Semi automatic delimiting system. One-year parts and labor warranty. Provide start-up inspection service by a factory authorized service agent. Provide options and accessories as indicated.

DIMENSIONS:

Floor space:	35.39" x 32.72" (899 x 831mm)
Unit height:	
Oven on stand	58.74" (1492mm)
Table model	41.57" (1055mm)

OVEN CLEARANCES:

From combustible and non-combustible construction

Right	4" (102mm)
Left	0" (0mm)
Back	2" (50mm)

Blodgett recommends and 12" (305mm) be maintained on the control side for servicing.

MINIMUM ENTRY CLEARANCE:

Uncrated	29.06" (738mm)
Crated	38" (965mm)

POWER SUPPLY:

Voltage	KW	Phase	Amperage
208 VAC	18	3	50
240 VAC	18	3	44
480 VAC	18	3	22

Other voltages available, contact factory

WATER SUPPLY & DRAIN:

Water Supply: Good quality water feed is the responsibility of the owner. Water quality must be within the following general guidelines.

TDS: < 100 ppm	Hardness: 80-120 ppm	pH: 7.0 - 8.0
Chlorides: < 30 ppm	Pressure: 40(min)-50(max) PSI	Chlorine: 0 ppm

3/4" hose cold water connection

The best defense against poor water quality is a water filter system designed to meet your water quality conditions. Blodgett offers optional water filters from Everpure and Terry Corp. for this unit.

Drain:

2" drain connection Maximum drain temperature 140°F (60°C)

Appliance is to be installed with backflow protection in accordance with Federal, State or Local codes.

SHIPPING INFORMATION:

Approx. weight: 545 lbs. (247 kg)

Crate size:

Oven	40" H x 47" W x 38" D (1016 x 1194 x 965 mm)
Stand	36" H x 42" W x 35" D (914 x 1067 x 889 mm)

NOTE: The company reserves the right to make substitutions of components without prior notice

BLODGETT OVEN COMPANY

www.blodgett.com • 44 Lakeside Avenue, Burlington, VT 05401 • Phone: (802) 658-6600 • Fax: (802) 864-0183