



BCX-14E

Single or Double Electric Combination-Oven/Steamer



Shown with optional casters

OPTIONS AND ACCESSORIES

(AT ADDITIONAL CHARGE)

- **Legs & Casters**
 - 6" (152.4mm) adjustable legs
 - 6" (152.4mm) seismic legs
 - 25" (635mm) adjustable legs
 - Stand mount casters
- MenuSelect control can hold multi-stage programming for up to 99 products, includes Cook & Hold, core probe cooking and USB port
- 480VAC, 3 phase
- Terry SM2 water filter
- Additional 4" core temperature probe
- Additional stainless steel wire shelves
- Chicken roasting rack
- Single source water manifold
- Water pressure regulator (1 per section)
- Extended warranty



Project _____

Item No. _____

Quantity _____

BCX-14E

All data is shown per oven section, unless otherwise indicated.
Refer to operator manual specification chart for listed model names.

EXTERIOR CONSTRUCTION

- Stainless steel top, front, sides and back
- Dual pane tempered viewing window with hinged inner glass for easy cleaning
- Door mounted condensate trough
- Top and bottom mount, easily adjustable door hinges
- Pivot out user interface panel for service access

INTERIOR CONSTRUCTION

- Fully welded stainless steel frame
- Fully insulated cooking chamber
- Fixed drain bottom center of cavity
- Easily removable stainless steel side rails
- Coved corner liner for ease of cleaning

OPERATION

- Standard control with function selection for steam, combi, hot air, and cool down
- Retherm band on control
- Steam on demand feature
- Thermostat control to 500F
- Multiple speed reversing fan for even bake
- Dual stage door latch to vent steam before fully opening door
- Cavity vent control provides ability to release steam at the push of a switch
- Integral door switch
- Open vented system. Condenses steam and drains away by-products of the cooking process, eliminates flavor transfer
- Self contained, self-flushing steam generator separate from cooking compartment for instant steam recovery when switching modes
- Control prompts user to delime when steam generator requires deliming

CAPACITY

- Fourteen 12" x 20" x 2-1/2" deep pans at 3-1/4" spacing
- Seven 18" x 26" deep pans at 3-1/4" spacing

STANDARD FEATURES

- Five (5) stainless steel wire shelves per section (capacity for 7)
- Hinged pressure panel for cleanability
- Halogen lights for superior cavity illumination
- Retractable hose reel (excluding top sections)
- Stacking kit and casters for double stack ovens
- Semi-auto delime system
- Deliming bottle and pump assembly
- Pressure spray bottle for oven cleaning
- 4" core temperature probe
- Floor stand with rack supports
- Start-up inspection service by factory authorized service agent
- One year parts and labor oven warranty*

* For all international markets, contact your local distributor.

BLODGETT COMBI

www.blodgett.com • 44 Lakeside Avenue, Burlington, VT 05401 • Phone: (802) 658-6600 • Fax: (802) 864-0183



BCX-14E



APPROVAL/STAMP

DIMENSIONS ARE IN INCHES (MM)

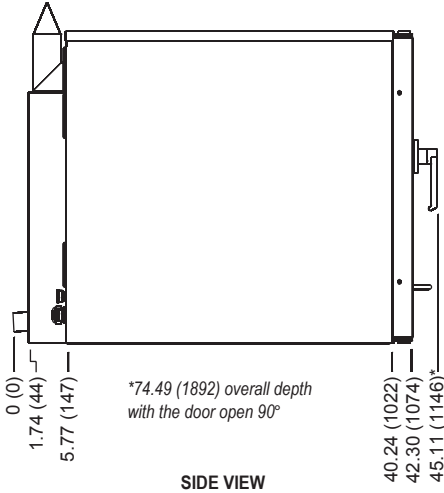

SIDE VIEW

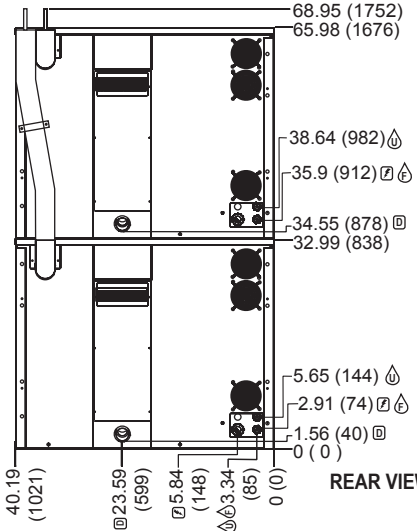

REAR VIEW

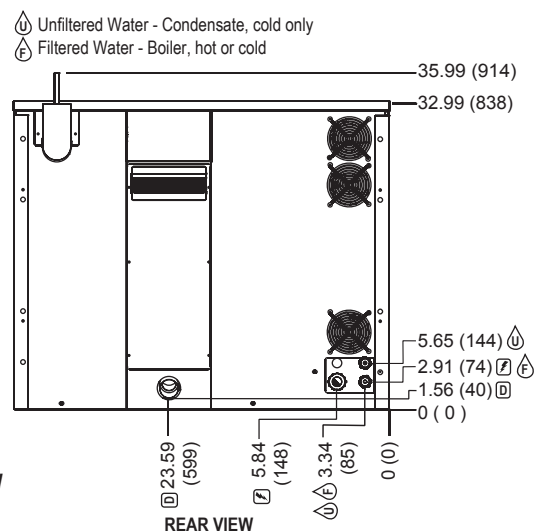

FRONT VIEW

SHORT FORM SPECIFICATIONS: Provide Blodgett Combi model BCX-14E single, electric combination-oven/steamer. Unit shall have the ability to cook with pressureless steam (212F), hot air, or combination of steam and hot air (with an operating range 140F to 500F), vario-steaming (operating range 140F to 212F), low temperature cooking and holding, rethermalizing, cool down mode and our Exclusive Steam on Demand steam injection system. Oven capacity to accept 7ea 18x26 bake pans or 14ea 12x20x2.5" full size steam table pans with 3-1/4" spacing. Front access service user interface control panel and service diagnosis system. Unit shall be constructed with a fully welded stainless steel frame. Cooking chamber shall be constructed with 304 series with bright-annealed stainless steel finish and coved corners. Retractable hose reel (excluding top sections) to include front water shut off valve. Oven cavity shall be open to the atmosphere with a thermostatically controlled quench box with a flow rate of less than 8 gallons per hour (total water consumption not to exceed 15 gallons per hour). Unit shall include a four speed, bi-directional fan with vent switch to control humidity in the cooking chamber. Dual pane thermal glass window with 180 degree door swing, two-step safety door-latch with adjustable door hinges, door mounted drip pan. Unit to include a detachable 4" core temperature probe and halogen lights. Supply with exclusive time to delime indicator with adjustable settings of 30, 60 or 90 hours of run time, semi-automatic deliming system. Where applicable, quantities in this spec are doubled for stacked units. A start-up inspection service will be performed by our factory-authorized agent at no cost to the operator. One-year parts and labor warranty, standard.

DIMENSIONS:

- Floor space:** 42.30" x 40.19" (1074 x 1021mm)
- Unit Height:**
 - Single 35.99" (914mm)
 - Double 68.98" (1752mm) without caster/legs

Additional Height:

- 6" adjustable legs 6.88" - 8" (174.6-203.2mm)
- 6" adjustable seismic legs 6.63" - 8" (168.3-203.2mm)
- 25" adjustable legs 25.25" - 26.38" (641.4-670mm)
- Low profile caster 4" (101.6mm)
- Stand w/rack supports 22.5" - 23.63" (571.5-600.1mm)
- Stand w/rack supports on casters 22.63" (574.7mm)

OVEN CLEARANCES:

- Right Side 2" (50.8mm)
- Left Side 2" (50.8mm)
- Rear 3" (76.2mm)

MINIMUM ENTRY CLEARANCE:

- Uncrated 33" (838mm)
- Crated 42" (1066.8mm)

NOTE: The company reserves the right to make substitutions of components without prior notice

POWER SUPPLY (per section):

- 208VAC 19.0 kW 3 phase (53 amp)
- 240VAC 19.0 kW 3 phase (46 amp)
- 480VAC 19.0 kW 3 phase (23 amp)

WATER SUPPLY & DRAIN:

Water Supply: Good quality water feed is the responsibility of the owner. Water quality must be within the following general guidelines.
TDS: < 100 ppm **Hardness:** 80-120 ppm **pH:** 7.0 - 8.0
Chlorides: < 30 ppm **Pressure:** 40(min)-50(max) PSI **Chlorine:** 0 ppm
 3/4" hose cold water connection
 The best defense against poor water quality is a water treatment system designed to meet your water quality conditions. Blodgett offers optional systems from Everpure and Terry Corp. for this unit.

Drain:

2" drain connection Maximum drain temperature 140°F (60°C)
 Appliance is to be installed with backflow protection in accordance with Federal, State or Local codes.

SHIPPING INFORMATION:

- Approx. Weight:**
 - Single section 615 lbs. (279 kg)
 - Double stack 1260 lbs. (571 kg)
 - Stand w/guides 140 lbs. (64 kg)

Crate size (per section):

44.5" H x 42" W x 54.5" D (1130 x 1067 x 1384mm)

BLODGETT

www.blodgett.com • 44 Lakeside Avenue, Burlington, VT 05401 • Phone: (802) 658-6600 • Fax: (802) 864-0183