



BLCP-102E
Single Electric
Boilerless Combination-Oven/Steamer
with Programmable Control



Shown on optional stand with shelf and adjustable feet

OPTIONS AND ACCESSORIES

(AT ADDITIONAL CHARGE)

- **Stands**
 - 21-1/2" tall stainless steel stand with wire shelf & adjustable feet
 - 21-1/2" tall stainless steel stand with wire shelf & casters
 - 21-1/2" tall stainless steel stand with runners & casters
- **Banquetting Accessories**
 - Pan cassette with 2.56" (65mm) spacing
 - Pan cassette with 3.35" (85mm) spacing
 - Plate cassette with 2.56" (65mm) spacing holds 63 plates
 - Plate cassette with 3.35" (85mm) spacing holds 51 plates
 - Transport trolley, to move the cassette
 - Insulated thermal blanket with vent
- CombiNet for monitoring and remote-controlling the oven via computer or internet. Functions include recipe management, HACCP, service diagnosis and software updating.
- Wire oven rack
- Right hinge door
- Extra year warranty

OPTIONS AND ACCESSORIES

(AT NO ADDITIONAL CHARGE)

- Optional rack with 2.56" (65mm) spacing

Project _____

Item No. _____

Quantity _____

- Standard rack with 3.35" (85mm) spacing holds eight full size sheet pans or sixteen 12" x 20" x 2-1/2" deep North American hotel pans
- Optional rack with 2.56" (65mm) spacing holds ten full size sheet pans or twenty 12" x 20" x 2" deep Gastronorm pans

Refer to operator manual specification chart for listed model names.

CONSTRUCTION

- 304 stainless steel exterior and interior
- Dual pane tempered viewing window with hinged inner glass for easy cleaning
- 2" (50mm) fixed drain in the bottom center of cavity
- Door mounted drip tray reduces the risk of wet, slippery floors
- Automatic door stops in positions of 110° and 180°
- Left hinge door is field convertible to the right side (with the purchase of conversion kit)
- Two step safety door latch. The first step stops the fan.

OPERATION

- Injection steam system - water is injected onto the heating elements, the resulting steam is distributed in the oven chamber by the fan wheel.
- Multiple cooking modes include hot air, CombiOptima, retherm, steaming, low-temperature steaming, forced steaming, proofing, cooling, and preheating
- CombiOptima automatically measures and controls the humidity level in the oven, helping to retain the appearance and juiciness of the product.
- Automated CombiWash, closed circuit cleaning system features very low water and detergent consumption and no contact with chemicals. No proprietary chemicals required, see owner's manual for detergent guidelines.
- Crystal clear TFT display with touch pad control
- Stores up to 200 recipe programs with 10 cooking stages each. Recipes can be grouped into fifteen categories (beef, chicken, cookies, etc.) for easy retrieval.
- Ability to run 2 core probes simultaneously
- Low temperature roast & hold and Delta-T cooking
- Reversible 9 speed fan for optimum baking and roasting results
- USB port for data and recipe transfer
- HACCP recording and documentation
- Programmable time delay start
- 85°-480°F (30°-250°C) temperature range, 575°F (300°C) preheating
- Automatic service diagnosis
- Low water indicator

STANDARD FEATURES

- External core temperature probe with multiple measuring points
- 21-1/2" tall stainless steel stand with runners & adjustable feet
- Bright halogen lights for superior visibility
- Built in hand shower
- Removeable cleaning chemical bottle shelf
- Start-up inspection service by factory authorized service agent
- One year parts and labor oven warranty*

* For all international markets, excluding Canada, contact your local distributor.



Intertek

BLODGETT COMBI

www.blodgett.com 44 Lakeside Avenue, Burlington, VT 05401
Phone: (802) 658-6600 • Fax: (802) 864-0183

BLCP-102E



BLCP-102E

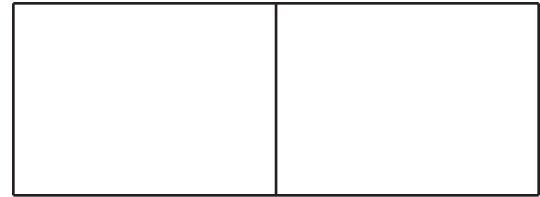

APPROVAL/STAMP

DIMENSIONS ARE IN INCHES (MM)

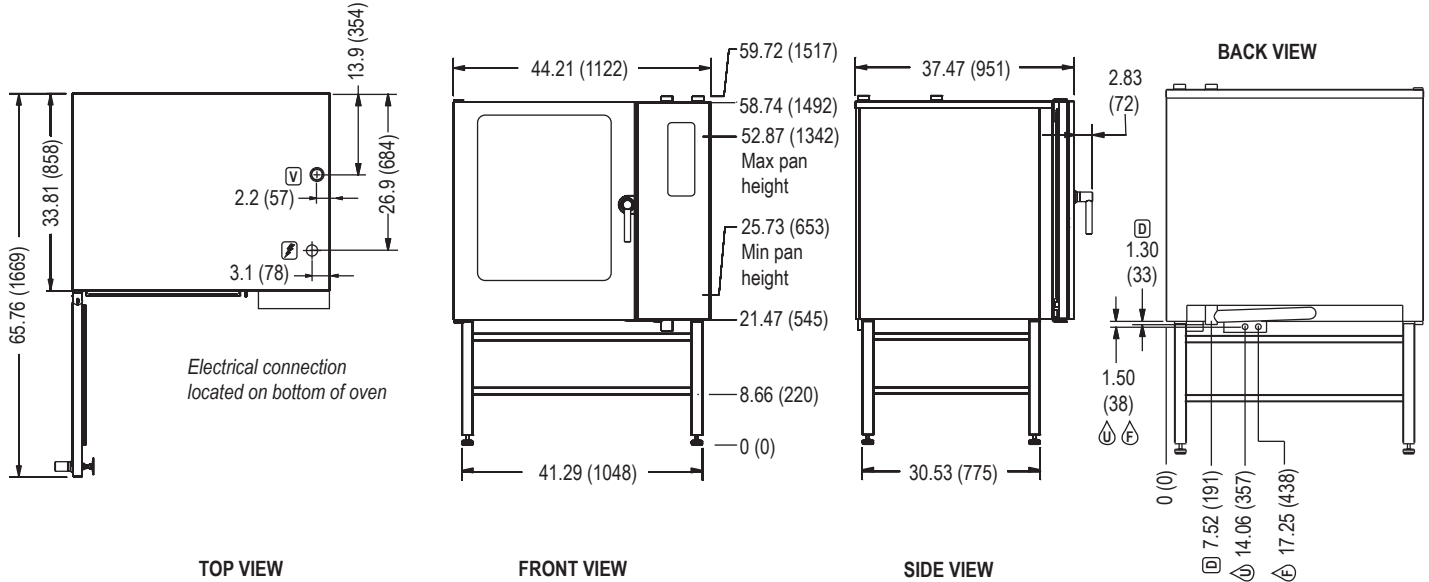

SHORT FORM SPECIFICATIONS: Provide Blodgett Combi model BLCP-102E boilerless combination-oven/steamer. The BLCP-102E rack with 3.35" (85mm) rack spacing holds eight full size sheet pans or sixteen 12" x 20" x 2-1/2" deep North American hotel pans. The optional rack with 2.5" (65mm) spacing holds ten full size sheet pans or twenty 12" x 20" x 2" deep Gastronorm pans. Unit shall have 304 stainless steel exterior and interior. Oven door shall have dual pane tempered viewing window with hinged inner glass for easy cleaning. Unit shall have the ability to cook with pressureless steam, hot air, or combination of steam and hot air. Unit shall have steam injection system. Multiple modes include hot air, combi with CombiOptima, retherming, steaming, low-temperature steaming, forced steaming, proofing, cooling, and preheating. Unit shall have bright halogen lights for superior visibility. Programmable control features crystal clear TFT display, ability to store up to 200 recipe programs with 10 cooking stages per program, recipes can be stored under categories for easy retrieval. Control also features programmable time delay start, delta-T cooking, USB connection to upload and download product recipes and CombiOptima automatic humidity control. HACCP quality control enables you to control and document production, data includes: production time, production duration, preparation temperature, and core temperature. The reversible 9 speed fan provides optimum baking and roasting results. Automated CombiWash, closed circuit cleaning system features very low water and detergent consumption and no contact with chemicals. One-year parts and labor warranty. Provide start-up inspection service by a factory authorized service agent. Provide options and accessories as indicated.

DIMENSIONS:

Floor space: 44.21" x 37.47" (1122 x 951mm)
Unit height:
 Oven on any stand w/feet 59.72" (1517mm)
 Oven on any stand w/casters 59.72" (1517mm)

OVEN CLEARANCES:

From combustible and non-combustible construction
 Right 4" (102mm)
 Left 0" (0mm)
 Back 2" (50mm)
 Blodgett recommends and 12" (305mm) be maintained on the control side for servicing.

MINIMUM ENTRY CLEARANCE:

Uncrated 37.47" (951mm)
 Crated 38" (965mm)

POWER SUPPLY:

Voltage	KW	Phase	Amperage
208 VAC	27	3	80
240 VAC	27	3	80
480 VAC	27	3	36

Other voltages available, contact factory

WATER SUPPLY & DRAIN:

Water Supply: Good quality water feed is the responsibility of the owner. Water quality must be within the following general guidelines.

TDS: < 100 ppm **Hardness:** 80-120 ppm **pH:** 7.0 - 8.0
Chlorides: < 30 ppm **Pressure:** 40(min)-50(max) PSI **Chlorine:** 0 ppm
 3/4" hose cold water connection

The best defense against poor water quality is a water filter system designed to meet your water quality conditions. Blodgett offers an optional water filters from Everpure and Terry Corp. for this unit.

Drain:

2" drain connection Maximum drain temperature 140°F (60°C)
 Appliance is to be installed with backflow protection in accordance with Federal, State or Local codes.

SHIPPING INFORMATION:

Approx. weight:

Oven only 569 lbs. (258 kg)
 Oven with stand 580 lbs. (263 kg)

Crate size:

81" H x 38" W x 39" D (2057 x 991 x 991mm)

NOTE: The company reserves the right to make substitutions of components without prior notice

BLODGETT COMBI

www.blodgett.com 44 Lakeside Avenue, Burlington, VT 05401 • Toll Free: (800) 331-5842 • Phone: (802) 860-3700 • Fax: (802) 864-0183