



BLCT-62G

**BLCT-62G**  
Full Size Single Gas  
Boilerless Combination-Oven/Steamer  
with Touchscreen Control



Shown on optional stand with wire rack and adjustable feet

Project \_\_\_\_\_

Item No. \_\_\_\_\_

Quantity \_\_\_\_\_

- Standard pan cassette with 3.35" (85mm) spacing holds five full size sheet pans or ten 12" x 20" x 2-1/2" deep North American hotel pans
- Optional pan cassette with 2.56" (65mm) spacing holds six full size sheet pans or twelve 12" x 20" x 2" deep Gastronorm pans

Refer to operator manual specification chart for listed model names.

**CONSTRUCTION**

- 304 stainless steel exterior and interior
- Dual pane tempered viewing window with hinged inner glass for easy cleaning
- 2" (50mm) fixed drain in the bottom center of cavity
- Door mounted drip tray reduces the risk of wet, slippery floors
- Automatic door stops in positions 110° and 180° for ease of loading and unloading and improved safety.
- Left hinge door is field convertible to the right side (with the purchase of conversion kit)
- Two step safety door latch. The first step stops the fan.

**OPERATION**

- Easy to use touchscreen control
- Multiple cooking modes include hot air, CombiSmart, CombiOptima, retherm, steaming, low-temperature steaming, forced steaming, proofing, preheating
- Stores up to 500 recipes with up to 15 steps each
- Manual or automatic cooling
- Automatic humidity pulsing
- External core temperature probe
- Rack timing allows for setting individual timers for each rack
- Reversible 9 speed fan for optimum baking and roasting results
- USB port for data and recipe transfer
- HACCP recording and documentation
- Automated CombiWash, closed circuit cleaning system features very low water and detergent consumption and no contact with chemicals. No proprietary chemicals required, see owner's manual for detergent guidelines.
- Semi automatic deliming system

**STANDARD FEATURES**

- Cassette support platform
- External core temperature probe with multiple measuring points. User-friendly location reduces strain on the probe
- 31-1/2" tall stainless steel stand with runners & adjustable feetBright halogen lights for superior visibility
- Built in hand shower
- Removeable cleaning chemical bottle shelf
- Start-up inspection service by factory authorized service agent
- One year parts and labor oven warranty\*

\* For all international markets, contact your local distributor.



**OPTIONS AND ACCESSORIES**

(AT ADDITIONAL CHARGE)

■ **Legs and Stands**

- 31-1/2" tall stainless steel stand with runners & casters
- Adjustable feet for table top installation

■ **Banqueting Accessories**

- Pan cassette with 2.56" (65mm) spacing
- Pan cassette with 3.35" (85mm) spacing
- Plate cassette with 2.56" (65mm) spacing holds 39 plates
- Plate cassette with 3.35" (85mm) spacing holds 33 plates
- Transport trolley, to move the cassette
- Insulated thermal blanket with vent

- Wire oven rack
- Right hinge door
- Extra year warranty

**OPTIONS AND ACCESSORIES**

(AT NO CHARGE)

- Optional pan cassette with 2.56" (65mm) spacing

**BLODGETT OVEN COMPANY**

www.blodgett.com • 44 Lakeside Avenue, Burlington, VT 05401 • Phone: (802) 658-6600 • Fax: (802) 864-0183



# BLCT-62G



APPROVAL/STAMP

DIMENSIONS ARE IN INCHES (MM)

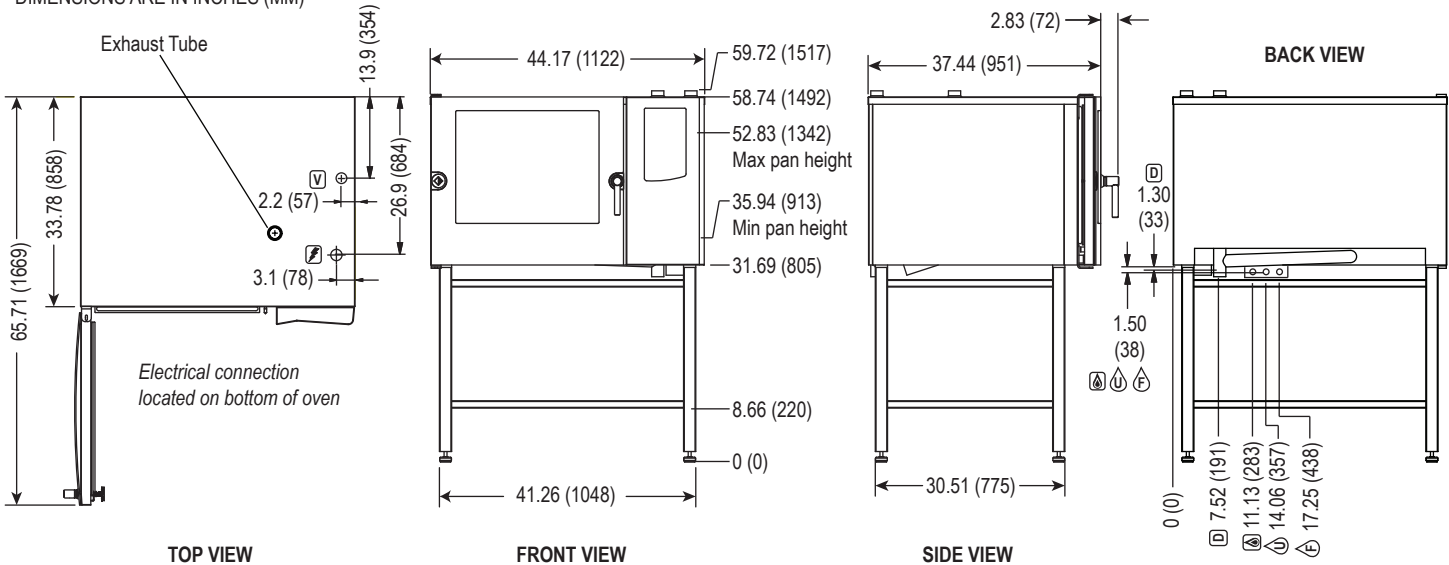

**SHORT FORM SPECIFICATIONS:** Provide Blodgett Combi model BLCT-62G combination-oven/steamer. The BLCT-62G has a pan cassette with 3.35" (85mm) spacing that holds five full size sheet pans or ten 12" x 20" x 2-1/2" deep North American hotel pans. The optional pan cassette with 2.5" (65mm) spacing holds six full size sheet pans or twelve 12" x 20" x 2" deep Gastronorm pans. Unit shall have 304 stainless steel exterior and interior. Oven door shall have dual pane tempered viewing window with hinged inner glass for easy cleaning. Unit shall have the ability to cook with pressureless steam, hot air, or combination of steam and hot air. Unit shall have steam injection system. Multiple modes include hot air, combi with CombiOptima, retherming, steaming, low-temperature steaming, forced steaming, proofing, cooling, and preheating. Unit shall have bright halogen lights for superior visibility. Touchscreen control stores 500 recipes with 15 stages each, in addition to pre-programmed recipes. External core temperature probe, rack timing allows for setting individual timers for each rack, HACCP quality control, USB connectivity, automatic service diagnosis. The reversible 9 speed fan provides optimum baking and roasting results. Automated CombiWash, closed circuit cleaning system features very low water and detergent consumption and no contact with chemicals. One-year parts and labor warranty. Provide start-up inspection service by a factory authorized service agent. Provide options and accessories as indicated.

## DIMENSIONS:

**Floor space:** 44.17" x 37.44" (1122 x 951mm)  
**Unit height:**  
 Oven on stand 58.74" (1492mm)  
 Table model 31.30" (795mm)

## OVEN CLEARANCES:

*From combustible and non-combustible construction*

Right 4" (102mm)  
 Left 0" (0mm)  
 Back 2" (50mm)

Blodgett recommends and 12" (305mm) be maintained on the control side for servicing.

## MINIMUM ENTRY CLEARANCE:

Uncrated 33.78" (858mm)  
 Crated 38" (965mm)

## GAS SUPPLY (per section):

3/4" NPT

### Inlet Pressure:

Natural 8.0" W.C. static to unit  
 Propane 14.0" W.C. static to unit

### Maximum Input:

81,800 BTU/hr

## POWER SUPPLY:

115 VAC, 1 phase, 9 amps

**Blodgett recommends a Pass & Seymour, model 2095, GFCI for this oven model due to the use of a variable frequency drive.**

## WATER SUPPLY & DRAIN:

**Water Supply:** Good quality water feed is the responsibility of the owner. Water quality must be within the following general guidelines.

TDS < 100 ppm      Alkalinity 80-120 ppm      pH 7.0 - 8.0      Sulfates <40 ppm  
 Chlorides < 30 ppm      Chlorine/Chloramine 0 ppm      Silica <13 ppm

*The best defense against poor water quality is a water filter system designed to meet your conditions. Blodgett offers optional water filters from Everpure and Terry Corp. for this unit.*

**Water Pressure:** 40(min)-50(max) PSI

**Water Connection:** 3/4" hose, cold water

### Drain:

2" drain connection      Maximum drain temperature 140°F (60°C)

Appliance is to be installed with backflow protection in accordance with Federal, State or Local codes.

## SHIPPING INFORMATION:

**Approx. weight:** 540 lbs. (245 kg)

**NOTE:** The company reserves the right to make substitutions of components without prior notice

## BLODGETT OVEN COMPANY

www.blodgett.com • 44 Lakeside Avenue, Burlington, VT 05401 • Phone: (802) 658-6600 • Fax: (802) 864-0183