



MRS 100/225/225CC Reverse Osmosis System

Configurable system that delivers reverse osmosis or blended water for multiple foodservice applications



- | | |
|------------------|-----------|
| MRS-100 System | EV9970-07 |
| MRS-225 System | EV9970-08 |
| MRS-225CC System | EV9970-09 |
| PRE-FILTER KIT | EV9795-81 |
| 6TO-BW Cartridge | EV9607-41 |
| MR-100 Cartridge | EV9627-11 |
| MR-225 Cartridge | EV9627-03 |
| 7CC-BW Cartridge | EV9627-05 |

BENEFITS

- Improves equipment life and performance by removing at least 90%+ of all dissolved solids that cause scale build-up
- Protects against taste and odor causing contaminants while removing dirt, particulates and dissolved minerals
- Less frequent deliming of equipment means reduced maintenance and service costs
- Sanitary cartridge replacement is simple, quick and clean. Internal filter parts are never exposed to handling or contamination
- Wall mount design allows flexible installation
- Reduces chlorine taste and odor and other offensive contaminants that can adversely affect taste of water and beverages
- Reduces limescale build-up that can cause excessive machine downtime and increased maintenance costs. Plus, scale reduction reduces energy costs

INSTALLATION TIPS

- Choose a mounting location suitable to support the full weight of the system when operating
- Deliming of equipment prior to application is recommended
- Never use saddle valve for connection
- Use 3/8" (min.) water line
- The water inlet must supply a minimum of 0.5 gpm
- Install vertically with cartridge hanging down and allow 2 inches above and below unit for cover removal and service access.
- Allow clearance to right of unit for optional pre-filter
- Refer to Installation, Operation & Maintenance Manual for cartridge flushing and RO start-up

OPERATION TIPS

- Change filter cartridges on a regular 6 month preventative maintenance program
- Change RO cartridges on a regular 2 year preventative maintenance program
- Change cartridges when capacity is reached
- Always flush the filter cartridge at time of installation and cartridge change

APPLICATION/SIZING

- Mineral Reduction System for foodservice applications
- Ideal for: Flash steamers, conventional steamers, cheese melters, combi-ovens and coffee/espresso machines
- Output capacity dependant on membrane selected:
 - 100 gallons per day (379 lpd)
 - 225 gallons per day (852 lpd)
- For use in coffee, steam, reconstitution, ice and multiple applications.

MRS 100/225/225CC

SPECIFICATIONS

Overall Dimensions:
30"H (34"-CC Model) x 15"W (20.5"
with Prefilter) x 8"D

Inlet and outlet connection:
3/8" OD tube connection

Wastewater line connection:
1/4" OD tube connection

Service Flow Rate:
Dependant on water pressure in storage tank
and line size (s) to equipment

Pressure Requirements:
Operating:
25 - 80 psi (1.7 - 5.5 bar), non-shock
Maximum Static:
100 psi (6.9 bar), non-shock

Electrical connection required:
115 Volts AC, 60 Hertz, 1 Phase

Water Supply:
0.5 gpm (1.9L) @ 50-85 psi (280-595 Kpa)

Inlet Temperature:
40°F - 100°F (4-38°C)

Inlet TDS:
1,500 ppm max recommended

Operating Weight: 35 lbs.
(not including storage tanks)

The contaminants or other substances removed or reduced by this system are not necessarily in your water. Do not use with water that is microbiologically unsafe or of unknown quality without adequate disinfection before or after the system.

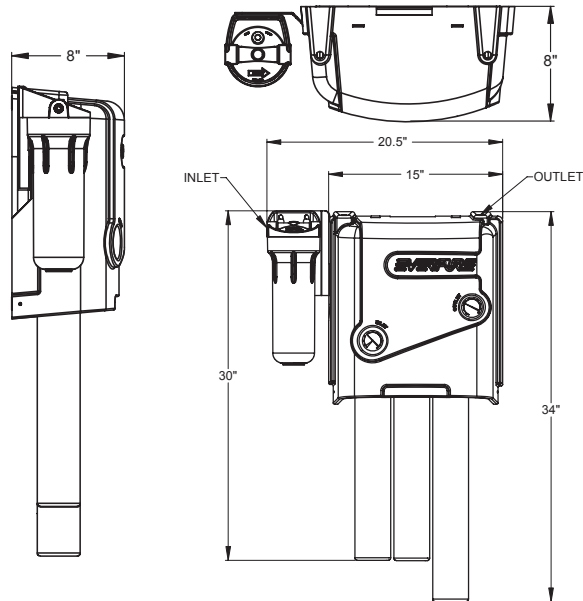

WARRANTY

MRS 100/225/225CC system (excluding replaceable elements) is covered by a limited warranty against defects in material and workmanship for a period of one year after the date of purchase. Everpure replaceable elements (filter cartridges and water treatment cartridges) are covered by a limited warranty against defects in material and workmanship for a period of one year after date of purchase. See printed warranty for details. Everpure will provide a copy of the warranty upon request.



Everpure offers a full line of water storage tanks. Contact your Everpure sales representative for more information.



EVERPURE, LLC
1040 Muirfield Drive
Hanover Park, Illinois 60133
Toll Free (800) 323-7873
Tel. (630) 307-3000
Fax (630) 307-3030
<http://www.everpure.com>

In Europe:
EVERPURE EUROPE B.V./B.A.
INDUSTRIEPARK WOLFSTEE
TOEKOMSTLAAN 30
B-2200 HERENTALS
BELGIUM
TEL 32-14-283500
FAX 32-14-283505

In Japan:
EVERPURE JAPAN LLC
HASHIMOTO MN BLDG. 7F
3-25-1 HASHIMOTO SAGAMIHARA-SHI
KANAGAWA 229-1103
JAPAN
TEL 81-(0)42-775-3011
FAX 81-(0)42-775-3015

Everpure
1040 Muirfield Drive
Hanover Park, IL 60133
Phone: 630-307-3000 Fax: 630-307-3030