



Automatic Hot Water Dispenser

Manufactured to the highest standards, Bloomfield automatic water dispenser combines style, function, reliability and value for money with a pioneering new development in water boiler filtration. A water filter is essential, not only in hard water areas to reduce problematic scale build-up, but also to remove impurities that can leave an unpleasant taste. Until now, these filters have always been plumbed in as a separate unit. This is unattractive and adds cost. FilterFlow is ingeniously different. It revolutionizes water boiler design by incorporating the filter cartridge within the boiler casing.

Key Features

- Type: Electric
- Electronic control system
- Standby mode
- LCD information panel
- Supplied with removable drip tray and water feed hose
- Built-in filtration cartridge
- Adjustable temperature (158 – 205°F)
- Advanced diagnostics
- Non-drip tap

Construction

- Body: stainless steel grade 430
- Internal tank: stainless steel grade 304
- Trim: Black ABS Plastic

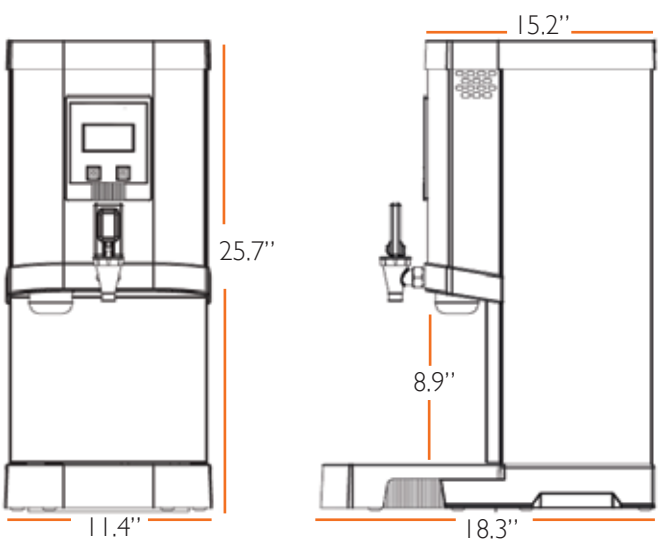

Specifications

H x W x D (in)	25.7 x 11.4 x 18.3
Power Rating (kW)	3.0
Standby power consumption (kW/hr)*	0.1
Output per hour	31 liters 55 pints 205 cups
Rapid draw off	9 liters 16 pints 60 cups
Recovery per minute	0.52 liters 0.92 pints
Boiling time**	26 minutes
Weight (lbs)	28.7

* The approximate power consumption when the boiler is full and to temperature. This is the typical consumption during periods of non-use, such as overnight.
 ** Boiling time is the time to heat to full capacity from empty.

