



Phoenix Heavy Duty Range with Charbroiler on a Cabinet Base



Shown with optional shelf and 24" riser

OPTIONS AND ACCESSORIES

(AT ADDITIONAL CHARGE)

- Flue riser
 - 12" high stainless steel short back riser
 - 24.5" high stainless steel high back riser
 - 30" high stainless steel high back riser
- Single-shelf (mounts on 24.5" flue riser)
 - Solid shelf
 - Tubed shelf
- Double-shelf (mounts on 36" flue riser)
 - Solid shelves
 - Tubed shelves
- Gas pressure regulator
 - 1"
 - 1-1/4"
- Interconnect gas line with quick disconnect
 - 36" long
 - 48" long
- Shelf for cabinet
- Cabinet door
- Common plate shelf
- Stainless steel dolly frame with casters
- Casters in lieu of adjustable legs
- Flanged feet with anchor bolts in lieu of adjustable legs
- Additional oven racks
- Michigan style shelf deflector

Project _____

Item No. _____

Quantity _____

- Model BP-18B** - one 18 wide charbroiler on a 18" wide cabinet base
- Model BP-24B** - one 24 wide charbroiler on a 24" wide cabinet base
- Model BP-36B** - one 36 wide charbroiler on a 36" wide cabinet base
- Model BP-48B** - one 48 wide charbroiler on a 48" wide cabinet base
- Model BP-60B** - one 60 wide charbroiler on a 60" wide cabinet base
- Model BP-72B** - one 72 wide charbroiler on a 72" wide cabinet base

SPECIFY

- | | | |
|----------------------------|---|---------------------------------------|
| Gas Type | <input type="checkbox"/> Natural Gas | <input type="checkbox"/> Propane |
| Front Manifold Cap & Cover | <input type="checkbox"/> Required | <input type="checkbox"/> Not Required |
| Rear Manifold* | <input type="checkbox"/> Rear (3/4") | <input type="checkbox"/> Rear (1") |
| Flue Riser Height | <input type="checkbox"/> 5" | <input type="checkbox"/> 12" (option) |
| | <input type="checkbox"/> 24.5" (option) | <input type="checkbox"/> 36" (option) |

Operating altitude (if above 2000 ft (700 meters)) _____

* 1-1/4" front manifold is provided on all units. 3/4" or 1" rear manifold connection is capped. Remove cap for rear manifold connection

STANDARD FEATURES (All models)

- One 15,000 BTU cast iron burner per 6" of charbroiler
- Heavy duty cast iron grates
- Built in grease guides channel away excess fat and reduce flaring
- Infinite control manual gas valves at each burner assure precise heat control
- Variable size multi-point gas connection
- Stainless steel gas tubing throughout
- One stainless steel pilot per burner
- 14 gauge welded body construction
- Stainless steel front, top, sides, bottom and flue riser
- 5" flue riser
- 6" stainless steel plate shelf
- Stainless steel tray bed for spill collection and easy cleaning
- 3/4" gas regulator shipped uninstalled (additional sizes available as options)
- Stainless steel cabinet interior and exterior
- 6" stainless steel adjustable legs
- Warranty: two year parts and one year labor warranty



PHOENIX HEAVY DUTY RANGE ON CABINET BASE

BLODGETT

www.blodgett.com

44 Lakeside Avenue, Burlington, VT 05401 • Phone: (802) 658-6600 • Fax: (802) 864-0183



PHOENIX CHARBROILER ON A CABINET BASE



APPROVAL/STAMP

36" WIDE UNITS SHOWN

Dimensions are in inches (mm)

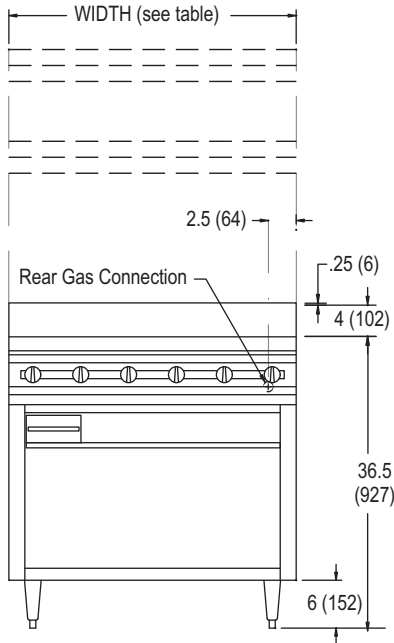

FRONT VIEW

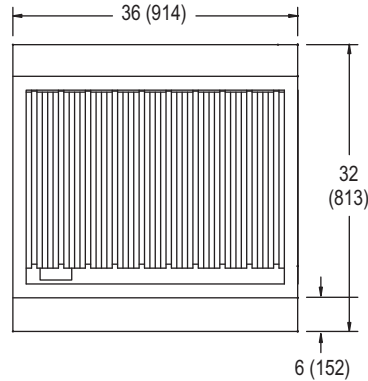

TOP VIEW

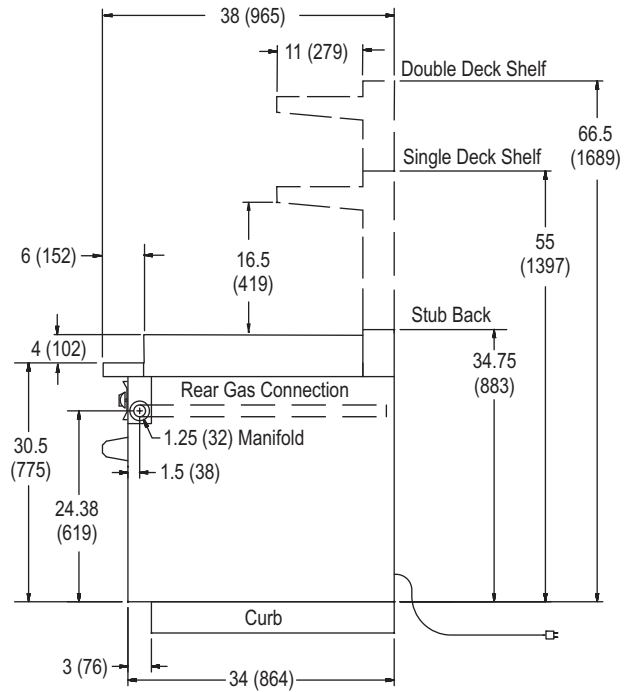

SIDE VIEW

MODEL	WIDTH	DEPTH	HEIGHT	SHIPPING WEIGHT
BP-18B	18"	38"	See drawing	300 lbs (136 kg)
BP-24B	24"			360 lbs (163 kg)
BP-36B	36"			475 lbs (215 kg)
BP-48B	48"			620 lbs (281 kg)
BP-60B	60"			750 lbs (340 kg)
BP-72B	72"			880 lbs (399 kg)

SHORT FORM SPECIFICATIONS

Provide Blodgett heavy duty charbroiler on a cabinet base. Top sections to consist of heavy duty cast iron grates, and built in grease guides channel away excess fat and reduce flaring. Unit shall have one 15,000 BTU/hr. cast iron burners per 6" of charbroiler controlled by infinite gas valves at each burner assure precise heat control. Unit shall have 14 gauge all welded body with stainless steel front and sides. All gas tubing to be stainless steel throughout with variable size, multipoint gas connection. 3/4" gas regulator provided. To be mounted on stainless steel cabinet base with 6" adjustable legs. Two year parts and one year labor warranty. Provide options and accessories as indicated.

UTILITY INFORMATION

MODEL	GAS RATING (BTU/hr)	OPERATING PRESSURE		GAS: Ranges are supplied with 1-1/4" front manifold connection and a 1" or 3/4" capped rear manifold connection. For rear manifold connection, remove cap. Ranges are supplied with 3/4" gas pressure regulator or 1-1/4" or 1" gas pressure regulator, see accessories. (Specify required front manifold cap and cover when ordering.) The unit must be connected with the gas regulator supplied. FLUE EXHAUST: Installation under a vented hood is recommended.
		Natural Gas	Propane	
BP-18B	45,000	5" W.C. min.	10 W.C. min. 14" W.C. max.	
BP-24B	60,000			
BP-36B	90,000			
BP-48B	120,000			
BP-60B	150,000			
BP-72B	180,000			

NOTE: The company reserves the right to make substitutions of components without prior notice

BLODGETT

www.blodgett.com 44 Lakeside Avenue, Burlington, VT 05401 • Phone: (802) 658-6600 • Fax: (802) 864-0183

Printed in U.S.A.

NOTE: FOR COMMERCIAL USE ONLY

P/N BR00063 Rev A (5/11)