



Synergy Steam

BTT-10E

Electric Countertop Tilting Braising Pan



10E-BTT BRAISING PAN

Project _____

Item No. _____

Quantity _____

- Model 10E-BTT (10 gallon electric tilting braising pan)

CONSTRUCTION

- 304 stainless steel
- Pan is heavy duty, 7" deep, one piece welded construction
- 3/8" thick stainless steel cooking surface prevents warping or distortion
- Electric heating elements are contained within the pan body to ensure efficient heat transfer across the entire cooking surface
- Trunnion located in the console and a left hand stabilizer.
- Polished pan interior for easy cleaning
- Thermostat, contractor, other electrical components and indicator light are mounted in a stainless steel, drip-proof console housing.

OPERATION

- Easy tilting manual tilt mechanism.
- Contoured front designed for maximum pouring control.
- Console mounted thermostat with indicator light

STANDARD FEATURES

- Etched markings (specify)
 - Gallons
 - Litres
- Standard voltage options (specify)
 - 208 VAC, 1 phase, 60 Hz
 - 208 VAC, 3 phase, 60 Hz
 - 240 VAC, 1 phase, 60 Hz
 - 240 VAC, 3 phase, 60 Hz
 - 480 VAC, 3 phase, 60 Hz
- One year parts and labor warranty*

* For all international markets, contact your local distributor.

OPTIONS AND ACCESSORIES
(AT ADDITIONAL CHARGE)

- Fill faucets with swing spout
- Lift off cover
- Stainless steel support stand





10E-BTT ELECTRIC COUNTERTOP TILTING BRAISING PAN



APPROVAL/STAMP

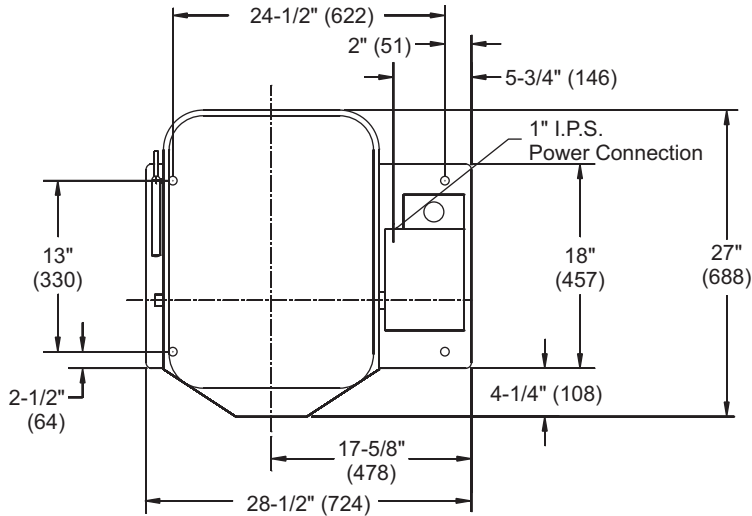

TOP VIEW

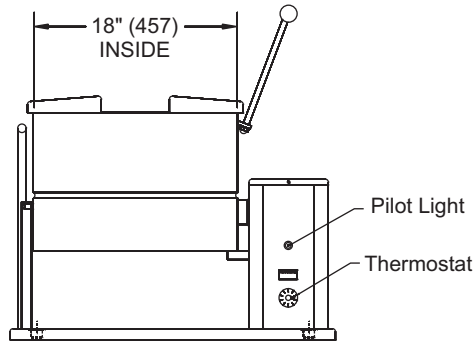

FRONT VIEW

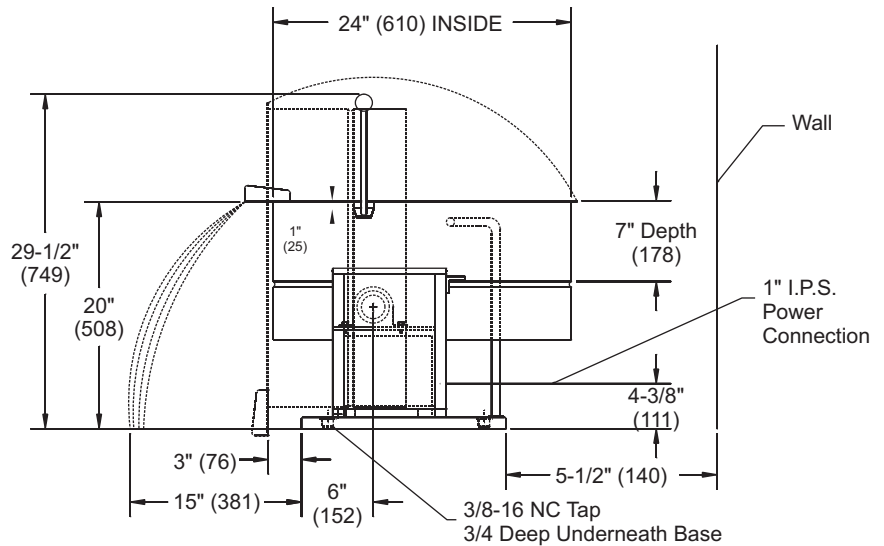

SIDE VIEW

SHORT FORM SPECIFICATIONS

Provide Blodgett model 10E-BTT, 10 gallon (38 litre) electric countertop braising pan. Unit shall be stainless steel, electric-heated, thermostatically controlled, trunnion mounted with pan dimensions of 18" x 24" x 7" (10 gallon liquid working capacity). Contoured front designed for maximum control in pouring. Pan returns to upright position when handle is released. Contractor, wiring and thermostat, all enclosed in stainless steel drip proof housing. Specify 208, 240 or 480 volts. 1 or 3 phase 60 cycle. Made in USA. One year parts and labor warranty. Provide options and accessories as indicated.

POWER CONNECTION:

Refer to data plate.

SHIPPING INFORMATION:

Approx. Weight:

10E-KTT 247 lbs. (112 kg)

VOLTS	PHASE	AMPS	KW
208	1	27.5	5.7
	3	16	
240	1	25	6
	3	14.5	
480	3	7.5	6

NOTE: The company reserves the right to make substitutions of components without prior notice.

BLODGETT

44 Lakeside Avenue, Burlington, VT 05401 Toll Free: (800) 331-5842 • Phone: (802) 860-3700 • Fax: (802) 864-0183