



Synergy Steam

G-SB

Convection Steamer on Gas Boiler Base

G-SB CONVECTION STEAMER



Project _____

Item No. _____

Quantity _____

- Model 6G-SB (6 pan convection steamer on a 24" gas boiler base)
- Model 10G-SB (10 pan convection steamer on a 24" gas boiler base)

CONSTRUCTION

- Stainless steel construction
- Stainless steel doors with strong continuous hinge and are field reversible for left or right swing
- Insulated doors have a one piece, replaceable seal
- Easy open handle and latch provide positive lock and seal when the door is pushed or slammed shut
- Hidden magnetic door switch cuts power to blower and steam flow to that cavity, when the door is opened
- Pan support racks shall be polished stainless steel and removable for easy cleaning
- Wide drip sink with condensate drain is positioned under cavity doors
- Gas heated, 24" wide cabinet base shall have stainless steel frame with all stainless steel top deck, hinged front access panel and removable side and rear panels
- Cabinet-mounted boiler is ASME Code-constructed and National Board registered for operation up to 15 PSI.
- Front and rear legs shall have adjustable bullet feet

OPERATION

- Steamer cavity controls are mounted on the front panel for easy access
- Separate ON-OFF/60 minute timer control with constant steam setting, for each steamer cavity.
- Gas boiler has a power-ON switch, RESET light, start switch, low water sensor, pop safety valve, water level sight glass and outside cabinet mounted pressure gauge.
- Unit will shut off if water level is low or unit builds too much pressure
- When power switch is turned "off", the boiler automatically drains to reduce sediment build-up, after the water has cooled to 140°F.
- Each steamer cavity shall have a powerful side mounted blower, which increases steam velocity and provides efficient steam distribution throughout cavity and between loaded pans.
- Twin gas-heated, cabinet-mounted pressure boiler to provide atmospheric steam to each chamber at a temperature of approximately 212° (F).
- Boiler delivers approximately 20,000 BTU/hr input per 2-1/2" deep steam pan capacity.
- Electronic ignition

CAPACITY

Pan Size	6G-SB	10G-SB
12" x 20" x 1"	12	20
12" x 20" x 2.5"	6	10
12" x 20" x 4"	4	6

STANDARD FEATURES

- 1/2" NPT power take-off valve for powering adjacent equipment (10 gallon model only)
- One year parts and labor warranty*

* For all international markets, contact your local distributor.

OPTIONS AND ACCESSORIES
(AT ADDITIONAL CHARGE)

- Flange mounting feet
- Second water connection for condensate spray



BLODGETT

44 Lakeside Avenue, Burlington, VT 05401 • Toll Free: (800) 331-5842 • Phone: (802) 658-6600 • Fax: (802) 864-0183



G-SB CONVECTION STEAMER



APPROVAL/STAMP

NOTES:

1. Drain connection: 1-1/4" NPT (includes automatic and manual boiler, steamers & condensate spray)
2. Cold water supply: 1/2" NPT (for boiler & condensate spray)
3. Optional separate condensate spray 3/8" NPT (add kit #MS102210)
4. Electrical connection: 7/8" dia hole (ref 1/2" conduit knock-out)
5. Gas connection 1/2" NPT
6. Steam power take-off 1/2" NPT
7. Minimum clearance required
8. Dimensions are in inches (mm).

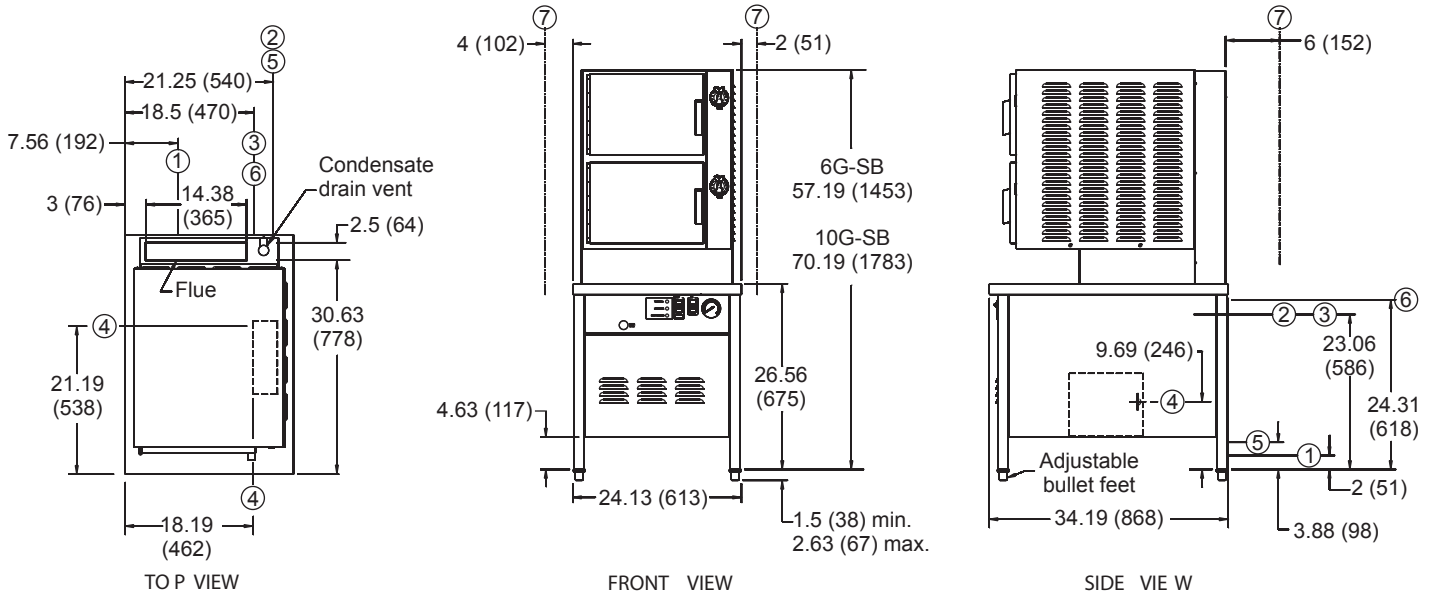
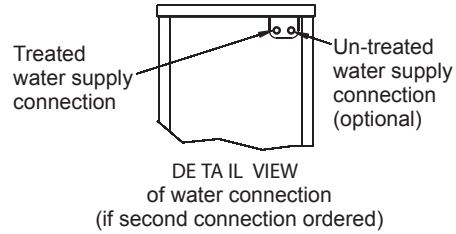

SHORT FORM SPECIFICATIONS

Provide Blodgett model 6G-SB (6 pan) or 10G-SB (10 pan) pressureless steamer with gas heated pressure boiler mounted in 24" wide cabinet base. All stainless steel construction with two independent steamer chambers, each with powerful blower to circulate steam within cavity and individual 60 minute timer, with constant steam setting. Insulated, field-reversible doors have easy open latch and hidden magnetic door switch. Drip sink with condensate drain is provided under cavity doors. Three 2-1/2" deep pan capacity per chamber. Cabinet base has stainless steel frame, all stainless steel exterior with removable lift-off panels and adjustable bullet feet. Generator ASME code-constructed for 15 PSI maximum, with 200,000 BTU firing rate, 120,000 BTU output and 3.7 boiler horsepower. Power takeoff to divert steam to adjacent equipment is standard, 10 gallon model only. AGA design-certified and standard with automatic boiler drain and electronic ignition. See back for water, drain, electric and gas connections. Provide options and accessories as indicated.

WATER SUPPLY:

Water quality is a major factor affecting the performance of your steamer. If you are unsure of water quality, consult a local water treatment specialist and have the water analyzed. Your water supply must be within these general guidelines:

Total dissolved solids: Less than 30 PPM	Total alkalinity: Less than 20 PPM
Silica: Less than 13 PPM	Chlorine: Less than 1.5 PPM
pH Factor: 7.0 - 9.0	

Water which fails to meet these standards should be treated by installation of a water conditioner. Failure or malfunction of this steamer due to poor water quality is not covered under warranty.

WATER & DRAIN CONNECTIONS:

Drain 1-1/4" NPT free venting drain
 Cold Water 1/2" NPT cold water supply line
 Appliance is to be installed with backflow protection in accordance with Federal, State or Local codes.

MAXIMUM INPUT:

200,000 BTU/hr

GAS SUPPLY:

1/2" NPT pipe or approved equivalent.

Minimum Inlet Pressure:

Natural 3.5" W.C. static to unit
 Propane 10.0" W.C. static to unit

POWER SUPPLY:

115 volt, single phase, 60 cycle 15 AMP electric service, 4 AMP maximum load

SHIPPING INFORMATION:

Approx. Weight:
 6G-SB 710 lbs. (332 kg)
 10G-SB 790 lbs. (359kg)

NOTE: The company reserves the right to make substitutions of components without prior notice.

BLODGETT

44 Lakeside Avenue, Burlington, VT 05401 • Toll Free: (800) 331-5842 • Phone: (802) 658-6600 • Fax: (802) 864-0183

Printed in U.S.A.

NOTE: FOR COMMERCIAL USE ONLY

P/N S00126 Rev D (11/13)