



G-SBC
Gas Boiler Free
Tabletop Convection Steamers



3G-SBC

OPTIONS AND ACCESSORIES

(AT ADDITIONAL CHARGE)

- Stainless steel support stand
- Pan racks for support stand
- Flanged foot kit for support stand
- Caster kit for support stand
- Heat shield kit
- 4" adjustable legs



Project _____

Item No. _____

Quantity _____

- Model 3G-SBC (3 pan gas boiler free steamer with plumbing connections)
- Model 5G-SBC (5 pan gas boiler free steamer with plumbing connections)

CONSTRUCTION

- Stainless steel construction
- Stainless steel doors with strong continuous hinge and are field reversible for left or right swing
- Insulated doors have a one piece, replaceable seal
- Easy open handle and latch provide positive lock and seal when the door is pushed or slammed shut
- Hidden magnetic door switch cuts power to blower and steam flow to that cavity, when the door is opened
- Pan support racks shall be polished stainless steel and removable for easy cleaning
- Gas connectionless steam reservoir is easy to clean through the cavity door.

OPERATION

- ON-OFF rocker switch
- Electronic timer with continuous steam setting
- Timed steam and stop buttons
- Ready light indicates when cavity is ready for steaming
- Unit shall come ready to steam in 15 minutes from a cold start, and provide warm cavity-instant steam capacity. Cavity is kept warm and ready for instant steam between loads.
- Each steamer cavity shall have a powerful side mounted blower, which increases steam velocity and provides efficient steam distribution throughout cavity and between loaded pans and no side vents for increased water/spray resistance.
- Steam generating reservoir provides atmospheric steam to the cavity at a temperature of approximately 212° F.
- Gas heater with infrared burners
- Steamer shall have a steam lid positioned over the steam generating reservoir to ensure that adding/removing food does not lower the cavity or water temperature.
- Automatic drain in steam reservoir

CAPACITY

Pan Size	3G-SBC	5G-SBC
12" x 20" x 1"	6 pans	10 pans
12" x 20" x 2.5"	3 pans	5 pans
12" x 20" x 4"	2 pans	3 pans

STANDARD FEATURES

- Front and rear legs shall have adjustable bullet feet
- One year parts and labor warranty*

* For all international markets, contact your local distributor.

G-SBC BOILER FREE CONVECTION STEAMERS

BLODGETT

44 Lakeside Avenue, Burlington, VT 05401 • Phone: (802) 658-6600 • Fax: (802) 864-0183



G-SBC BOILER FREE STEAMERS

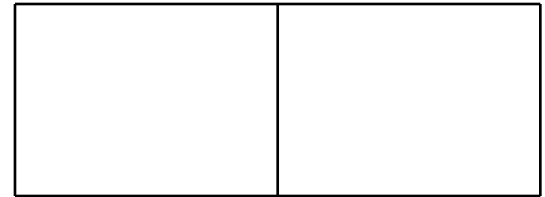

APPROVAL/STAMP

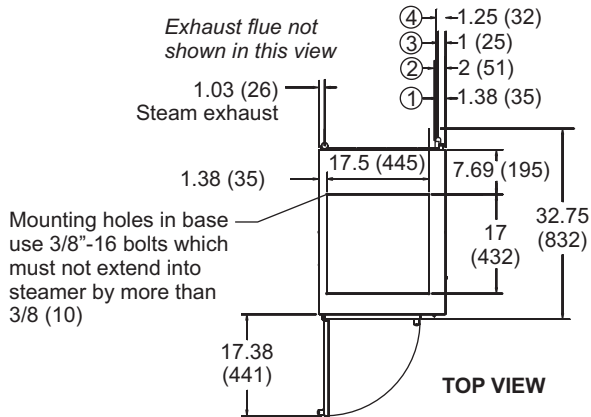

DIMENSIONS ARE IN INCHES (MM)

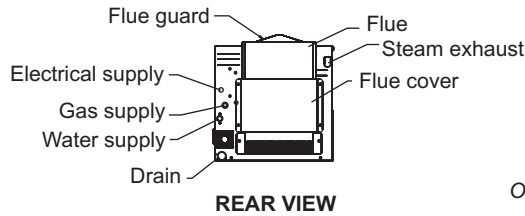
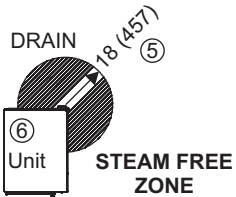
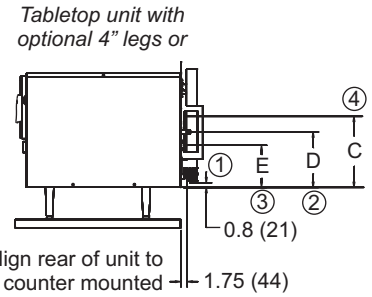
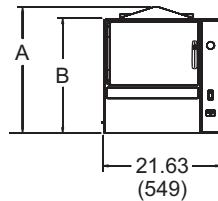

NOTES:

- Drain connection:** 1.5 (38) hose type (drain free venting). DO NOT connect directly to drain, allow 2" air gap.
- Gas connection:** 1/2" FPT
- Water supply:** 3/4" male hose connection. 30 to 60 PSIG with a flow rate of 0.75-1.50 GPM. Pressure regulation is required for water pressure over 60 PSI. DO NOT use treated water.
- Electrical connection:** conduit hose size = 13/16" hole.
- If the floor drain only services this steamer, then the drain may be located within the steam free zone. Steam free zone must be observed if other appliances cause steam at the floor drain.
- Do not install steamer directly above steam venting floor drains.

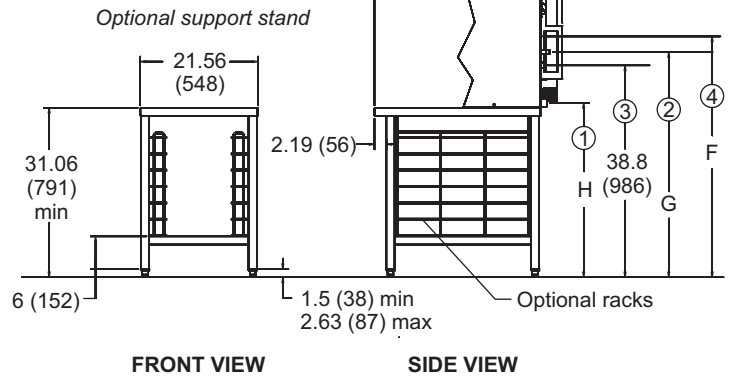

SHORT FORM SPECIFICATIONS

Provide Blodgett model 3G-SBC (3 pan) or 5G-SBC (5 pan) boilerfree steamer with with self-contained, atmospheric, gas heated steam generating reservoir. Construction shall be all stainless steel. Cavity shall have a powerful side-mounted blower to circulate steam. Standard operating controls shall include: an on-off rocker switch; electronic timer, with continuous steam, timed steam and stop buttons; READY light. Door shall be field-reversible and shall be equipped with an easy-open latch and hidden magnetic door switch. The atmospheric steam generating reservoir shall not require a pressure gauge or switches; shall have an automatic drain and shall have an infrared burner with heating capacity of 54,000 BTU/hr for 3G-SBC and 62,000 BTU/hr for 5G-SBC. Steamer shall come up to READY in 15 minutes from a cold start and shall provide warm cavity, instant steam capability. Provide options and accessories as indicated.

	3G-SBC	5G-SBC
A	23.06 (585)	28.88 (733)
B	21 (534)	27.56 (700)
C	13 (330)	15 (381)
D	10.13 (258)	11 (279)
E	7.69 (196)	7.75 (197)
F	44.13 (1121)	46.06 (1169)
G	41.25 (1048)	42.06 (1068)
H	31.94 (812)	31.88 (810)

MAXIMUM INPUT:

3G-SBC 54,000 BTU
5G-SBC 62,000 BTU

GAS SUPPLY:

Minimum Inlet Pressure:
Natural 4.3" W.C. static to unit
Propane 10.5" W.C. static to unit

MINIMUM REQUIRED CLEARANCES:

Left and right side 2" (51mm)
Rear 6" (152mm)

POWER SUPPLY:

115 volt, single phase, 60 cycle 15 AMP electric service, 4 AMP maximum load

SHIPPING INFORMATION:

3G-SBC 240 lbs. (109 kg)
5G-SBC 272 lbs. (124 kg)

NOTE: The company reserves the right to make substitutions of components without prior notice.

BLODGETT

44 Lakeside Avenue, Burlington, VT 05401 • Phone: (802) 658-6600 • Fax: (802) 864-0183