



Synergy Steam

DS-KPS

Direct Steam Pedestal Stationary Kettle



Project _____

Item No. _____

Quantity _____

- Model 20DS-KPS - 20 gallon (76 litres) direct steam pedestal stationary kettle
- Model 40DS-KPS - 40 gallon (151 litres) direct steam pedestal stationary kettle

CONSTRUCTION

- 316 stainless steel, one-piece welded construction
- 2/3 jacketed kettle
- All exposed surfaces shall be stainless steel
- Heavy, durable bar rim with a continuous seal weld on the underside to ensure maximum durability and sanitation.
- ASME shop inspected, stamped and registered with the National Board for operation up to a maximum working pressure of 25 PSI
- Stainless steel pedestal base, with the outer circumference of the pedestal flanged down vertically to ensure proper sealing to the floor or deck

STANDARD FEATURES

- Faucet bracket
- One-piece, hinged design dome cover
- 2" sanitary tangent drawoff
- Removable 1/4" perforates stainless steel strainer
- One year parts and labor warranty*

* For all international markets, contact your local distributor.



DS-KPS PEDESTAL STATIONARY KETTLE

OPTIONS AND ACCESSORIES

(AT ADDITIONAL CHARGE)

- Etched markings
 - Gallons
 - Litres
- Faucets
 - Single pantry faucet
 - Double pantry faucet
- Strainer
 - 1/8" perforated disc strainer
 - 1/4" perforated disk strainer
 - Solid disc strainer
- Basket inserts
- Higher working pressure
- 3" tangent drawoff
- Cold water cooling
- Steam trap assemblies
- Kettle brush kit
- Steam regulators
- Contour measuring strip

BLODGETT

www.blodgett.com

44 Lakeside Avenue, Burlington, VT 05401 • Phone: (802) 8658-6600 • Fax: (802) 864-0183



DS-KPS PEDESTAL STATIONARY KETTLE

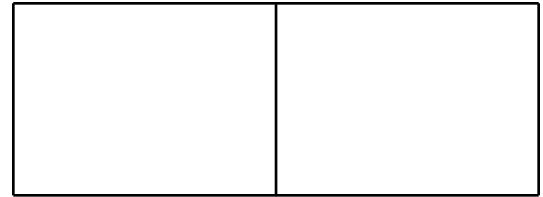

APPROVAL/STAMP

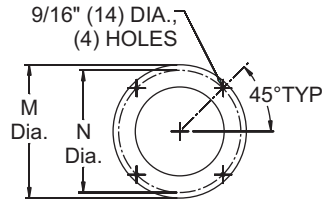
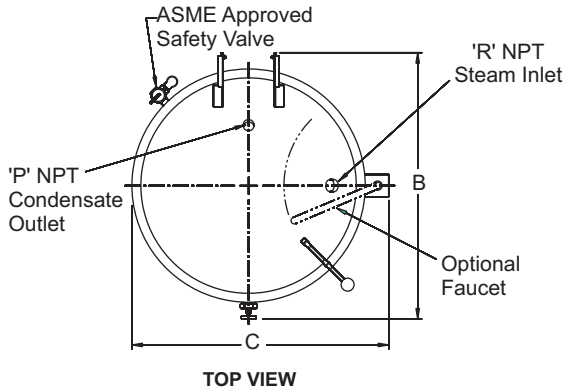

NOTES:

1. Kettle must be securely anchored to the floor.
2. Position center of tangent drawoff spout 4-5" over floor sink for proper operation.
3. Dimensions are in inches (mm).

NOTE: Cover is not shown in this view

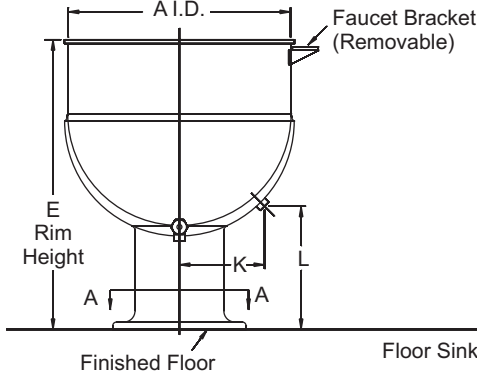

FRONT VIEW

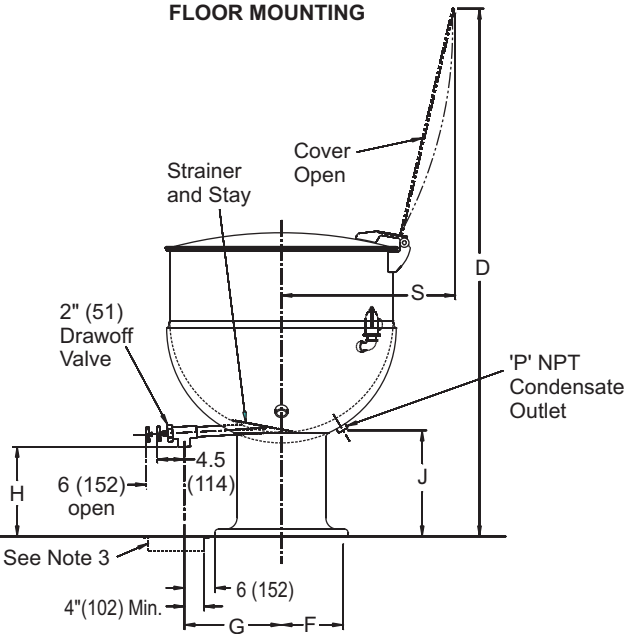

RIGHT SIDE VIEW

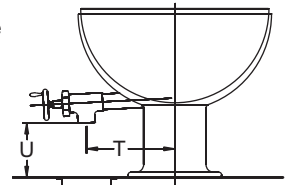

OPTIONAL 3" TANGENT DRAWOFF

SHORT FORM SPECIFICATIONS

Provide Blodgett model 20DS-KPS (20 gallon) or 40DS-KPS (40 gallon) direct steam pedestal stationary kettle. Unit shall be solid one-piece welded construction with heavy duty reinforced bar rim. 2" sanitary tangent drawoff standard. 20- and 40-gallon units filled with one-piece hinged dome cover. NSF listed, ASME code constructed for 25 PSI. Unit mounted on all stainless steel pedestal with outer circumference flanged vertically to ensure sealing to floor or deck. Steam trap assembly and direct steam source required. Provide options and accessories as indicated.

MAXIMUM PRESSURE (all models):

25 PSI (173 kPa) (optional higher working pressure is available)

SHIPPING INFORMATION:

Approx. Weight:

20DS-KPS 179 lbs. (81 kg)
40DS-KPS 220 lbs. (100 kg)

NOTE: The company reserves the right to make substitutions of components without prior notice.

	20DS-KPS	40DS-KPS
A	20 (504)	26 (660)
B	26.25 (667)	31.75 (806)
C	22 (559)	28 (711)
D	59 (1499)	65 (1651)
E	36 (914)	36 (914)
F	5.5 (140)	7 (178)
G	12 (305)	13.25 (343)
H	15.5 (400)	11.75 (298)
J	17 (432)	14 (356)
K	8 (203)	10.25 (260)
L	18.75 (476)	15.75 (400)
M	12 (305)	16 (406)
N	10.25 (260)	14.5 (368)
P	0.5 (13)	0.5 (13)
R	0.5 (13)	0.75 (19)
S	18 (457)	25 (635)
T	14 (356)	16 (406)
U	14.75 (375)	10.75 (273)

BLODGETT

www.blodgett.com

44 Lakeside Avenue, Burlington, VT 05401 • Phone: (802) 8658-6600 • Fax: (802) 864-0183