



Synergy Steam

E-BLT
Electric Floor Model Braising Pan with Manual Tilt



OPTIONS AND ACCESSORIES

(AT ADDITIONAL CHARGE)

- Faucets
Single pantry faucet
Double pantry faucet
Spray hose assembly for pantry faucets
48" (1219 mm)
60" (1524 mm)
Steam pan insert
Steam pan carrier
2" tangent drawoff (must be ordered with unit)
Strainer for tangent drawoff valve
Pouring lip strainer
Flanged feet
Casters

Project _____
Item No. _____
Quantity _____

- Model 30E-BLT (30 gallon, narrow width, electric braising pan with manual tilt)
Model 40E-BLT (40 gallon, narrow width, electric braising pan with manual tilt)

CONSTRUCTION

- 304 stainless steel
Pan is heavy duty, 10" deep, one piece welded construction
5/8" thick stainless steel cooking surface prevents warping or distortion
Flat bar electric heating elements ensure efficient heat transfer across the entire cooking surface
Control and tilt mechanism are mounted in stainless steel housings on the pan body sides
100 grit interior finish is coarse enough to retain butter, shortening or oil during the cooking process, minimizing food sticking and burning.
A heavy-gauge, fully adjustable one-piece cover is standard with torsion bar type counterbalance designed to maintain selected cover position.
True rounded leg tubular stand design and 3" radius pan interiors make cleaning easier.

OPERATION

- Smooth-action, quick-tilting body with manual crank tilt mechanism, which provides precise control during pouring of pan contents for easy operation
Pan tilts past vertical for easy cleaning
Controls allow operation at a 7 degree angle to facilitate griddling.
Thermostatically controlled for automatic shut-off when desired temperature is reached or heating when temperature falls below desired setting
High limit thermostat for safety
Console mounted power switch with indicator light
Control includes a heat indicator light and temperature control switch
A vent in the cover top regulates condensate buildup and a rear condensate drip shield is located under the cover to prevent condensate from dripping on floor when cover is opened.

STANDARD FEATURES

- Mounting bracket for either right, left or rear faucet mounting
Etched markings (specify)
Gallons
Litres
Standard voltage options (all units are field convertible to 1 phase)
208 VAC, 3 phase, 60 Hz
240 VAC, 3 phase, 60 Hz
480 VAC, 3 phase, 60 Hz
One year parts and labor warranty*

* For all international markets, contact your local distributor.



E-BLT BRAISING PAN WITH MANUAL TILT

BLODGETT

44 Lakeside Avenue, Burlington, VT 05401
Toll Free: (800) 331-5842 • Phone: (802) 860-3700 • Fax: (802) 864-0183



E-BLT ELECTRIC BRAISING PAN WITH MANUAL TILT



APPROVAL/STAMP

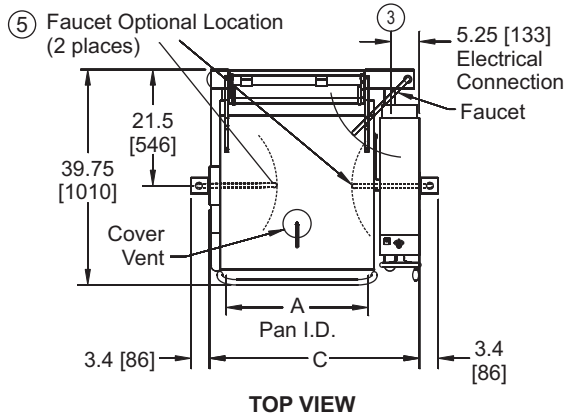

NOTES:

1. Dimensions are in Inches [mm]
2. Casters or flanged feet available at an extra cost.
3. Electrical Connection: 0.1.75" dia. [44] hole
4. Other voltages and phases are available.
5. Faucet bracket may be installed on left or right side.
6. Faucet may be installed on faucet bracket or on rear as shown.

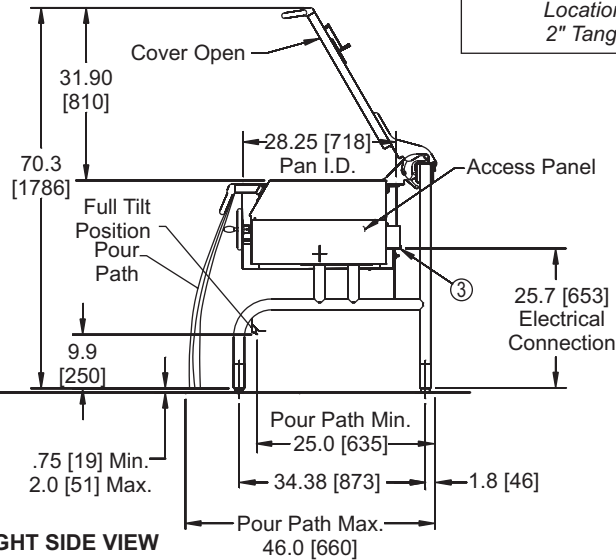
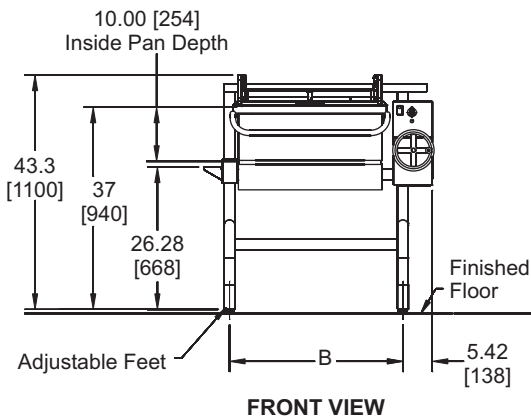
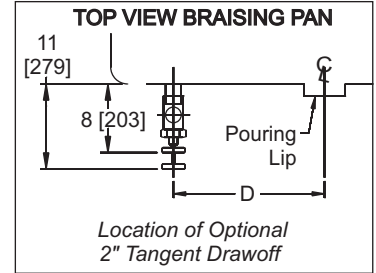

MODEL	A	B	C	D
30E-BLT	26.25 (667)	32 (813)	38.5 (984)	8.75 (222)
40E-BLT	35.75 (908)	41.5 (1054)	48 (1226)	13.5 (343)

SHORT FORM SPECIFICATIONS

Provide Blodgett model 30E-BLT, 30 gallon (114 litre) or 40E-BLT (152 litre) electrical braising pan. Unit shall be stainless steel, electric-heated, thermostatically controlled, on a rounded tubular leg stand. Heavy 5/8" thick stainless steel clad pan bottom with clamped-on flat bar-type electric heating elements. 30 gallon pan is 39" wide and 40 gallon pan is 48" wide both with a 10" deep pan. Smooth-action quick tilting pan body with manual crank tilt mechanism, heavy-duty fully adjustable counterbalanced cover with condensate drip shield and cover vent. Single electric connection required; specify voltage (208, 240 or 480 Volt). UL- and NSF- listed. Made in USA. One year parts and labor warranty. Provide options and accessories as indicated.

POWER CONNECTION:

Refer to data plate.

SHIPPING INFORMATION:

Approx. Weight:

- 30E-BLT 463 lbs. (210 kg)
- 40E-BLT 535 lbs. (243 kg)

		AMPS PER LINE			
Model	kW	Phase	208V	240V	480V
30E-BLT	11.5 kW	1	55	48	n/a
		3	32	28	14
40E-BLT	15.3 kW	1	74	64	n/a
		3	43	37	19

NOTE: The company reserves the right to make substitutions of components without prior notice.

BLODGETT

44 Lakeside Avenue, Burlington, VT 05401 Toll Free: (800) 331-5842 • Phone: (802) 860-3700 • Fax: (802) 864-0183