



Synergy Steam

40GS-KLT
Short Height Gas Floor Model Tilting Kettle



40GS-KLT TILTING FLOOR KETTLE

Project _____
Item No. _____
Quantity _____

- Model 40GS-KLT - 40 gallon (151 litres) gas tilting floor kettle

CONSTRUCTION

- 316 stainless steel, one-piece welded construction
Fully jacketed kettle
All exposed surfaces shall be stainless steel
Kettle body is sheathed in stainless steel and air gap insulated.
ASME shop inspected, stamped and registered with the National Board for operation up to a maximum working pressure of 50 PSI.
Outer sheathing and air insulating gap retains heat and keeps kettle exterior cooler to the touch.
Heavy-duty stainless steel combination kettle support tilt trunnion on an enclosed base.
Stainless steel tubular legs with adjustable bullet feet
Heavy reinforced bar rim with a welded-in butterfly shaped pouring lip for pouring control and durability

OPERATION

- Gas-heated (natural, butane, propane) self-contained steam source to provide kettle temperatures of 150 to approximately 295°F
Patented fin tube burner assembly delivers 62-65% efficient combustion, depending on kettle size
Thermostatically controlled to shut off automatically when desired temperature is reached or on when temperature falls below desired setting
Factory charged with chemically-pure water and rust inhibitors to ensure long life and minimum maintenance
Smooth operating, self-locking tilt mechanism
Thermostat
Pressure gauge
Safety valve
Pressure limit control
Water sight glass
Lower water cut off
Gas regulator valve
Electronic ignition to standing pilot
Power on switch
Power on, heating, and low water indicator lights
Gas supply shuts off automatically when the unit is tilted

STANDARD FEATURES

- Faucet bracket
Removable 1/4" perforated stainless steel strainer
One year parts and labor warranty*

* For all international markets, contact your local distributor.

OPTIONS AND ACCESSORIES (AT ADDITIONAL CHARGE)
Etched markings
Gallons
Litres
Strainers
1/8" perforated disc strainer
1/4" perforated disk strainer
Solid disc strainer
Lip strainers
Faucets
Single pantry faucet
Double pantry faucet
Covers
Lift off cover
Hinged cover kit
2" tangent drawoff with 1/8" perforated disc strainer
Basket inserts
Pan carrier for 40 and 60 gallon kettles
Kettle brush kit
Contour measuring strip





40GS-KLT TILTING FLOOR KETTLE

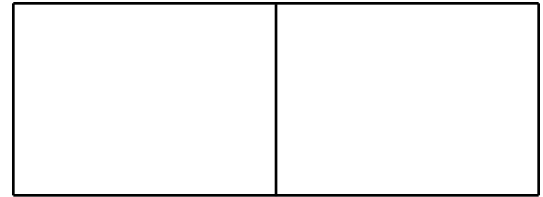

APPROVAL/STAMP

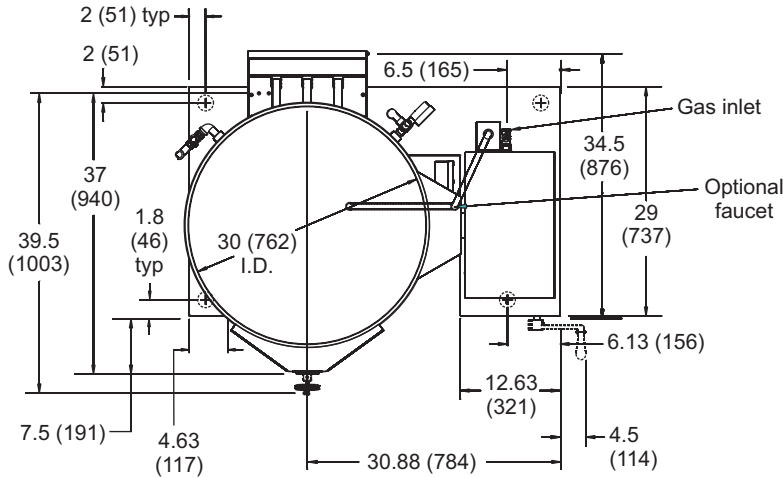

TOP VIEW

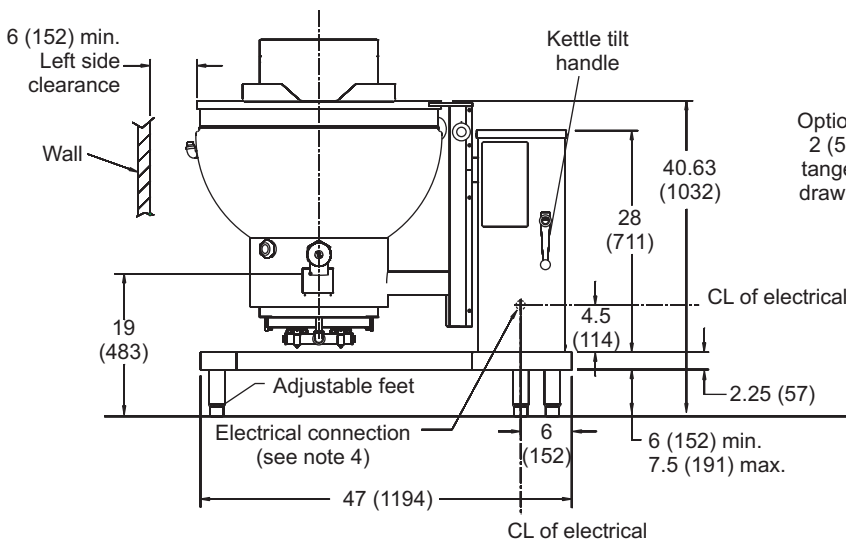

FRONT VIEW

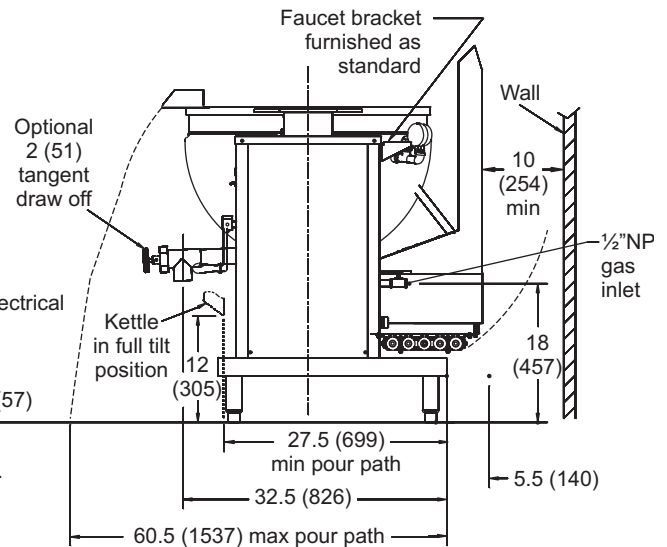

RIGHT SIDE VIEW

NOTES:

1. Dimensions are inches (mm).
2. Customer to supply water resistant conduit fitting for electrical supply
3. Minimum distance from combustible walls: 6 (152) on sides and 10 (254) from rear. Blodgett recommends 10 (254) on right side for servicing.

SHORT FORM SPECIFICATIONS

Provide Blodgett model 40GS-KLT (40 gallon) short height gas fired, stainless steel, fully steam jacketed kettle. All stainless steel construction with reinforced bar rim, butterfly shaped pouring lip and smooth action mechanical tilt. Patented fin tube burner assembly is 77-80% combustion efficiency, with electronic ignition standard. NSF listed, ASME code constructed for 50 PSI and CSA. design certified Provide options and accessories as indicated.

MAXIMUM INPUT:

40G-KLT 150,000 BTU

GAS SUPPLY:

1/2" NPT connection required. A gas shut-off valve must be installed in supply piping convenient and adjacent to unit.

Inlet Pressure:

Natural 3.5" W.C. min, 14" W.C. max
Propane 10" W.C. min, 14" W.C. max

ELECTRICAL CONNECTION:

Requires one 115 Volt, single-phase, 60 HZ, 5 AMP supply.

SHIPPING INFORMATION:

Approx. Weight:
40GS-KLS 645 lbs. (47.3 kg)

NOTE: The company reserves the right to make substitutions of components without prior notice.

BLODGETT

www.blodgett.com 44 Lakeside Avenue, Burlington, VT 05401 • Phone: (802) 658-6600 • Fax: (802) 864-0183