



G-KLS Gas Tri-Leg Stationary Kettle



OPTIONS AND ACCESSORIES

(AT ADDITIONAL CHARGE)

- Etched markings
 - Gallons
 - Litres
- Strainer
 - 1/8" perforated disc strainer
 - 1/4" perforated disk strainer
 - Solid disc strainer
- Basket inserts
- Swing faucets
- Automatic water filler
- 3" tangent drawoff
- Kettle brush kit
- Contour measuring strip

Project _____

Item No. _____

Quantity _____

- Model 20G-KLS - 20 gallon (76 litres) gas tri-leg stationary kettle
- Model 40G-KLS - 40 gallon (151 litres) gas tri-leg stationary kettle
- Model 60G-KLS - 60 gallon (227 litres) gas tri-leg stationary kettle
- Model 80G-KLS - 80 gallon (303 litres) gas tri-leg stationary kettle
- Model 100G-KLS - 100 gallon (379 litres) gas tri-leg stationary kettle

CONSTRUCTION

- 316 stainless steel, one-piece welded construction
- 2/3 jacketed kettle
- All exposed surfaces shall be stainless steel
- Kettle body is sheathed in stainless steel and air gap insulated.
- ASME shop inspected, stamped and registered with the National Board for operation up to a maximum working pressure of 30 PSI. Unit shall be UL listed for sale in USA and Canada. Unit shall be registered in Canada with a CRN number.
- Outer sheathing and air insulating gap retains heat and keeps kettle exterior cooler to the touch.

OPERATION

- Gas-heated, self-contained steam source provides temperatures of 150 to 270°F
- Gas regulator valve and electronic ignition module
- Thermostatically controlled to shut off automatically when desired temperature is reached or on when temperature falls below desired setting
- Factory charged with chemically-pure water and rust inhibitors to ensure long life and minimum maintenance
- All controls are front mounted in easy reach of the operator
- Regulating thermostat
- Pressure gauge
- Power on/off switch
- Heat, power and lower water indicator lights
- Water level sight glass
- Pressure safety relief valve
- Pressure limit control
- Low water cut-off

STANDARD FEATURES

- One-piece, hinged design dome cover on 20 gallon units.
- One-piece domed cover with counter balanced spring-assist on 40, 60, 80 and 100 gallon units
- Faucet bracket
- 2" sanitary tangent drawoff
- Removable 1/4" perforated stainless steel strainer
- One year parts and labor warranty*

* For all international markets, contact your local distributor.



G-KLS TRI-LEG STATIONARY KETTLE

BLODGETT

www.blodgett.com

44 Lakeside Avenue, Burlington, VT 05401 • Phone: (802) 658-6600 • Fax: (802) 864-0183



G-KLS TRI-LEG STATIONARY KETTLE



APPROVAL/STAMP

NOTES:

1. Hinged cover standard on 20 gallon kettle.
2. Power aid cover (shown) standard on 40-100 gallon kettles.
3. Single or double pantry faucets are optional.
4. 3" tangent drawoff is optional.
5. Dimensions are in inches (mm).

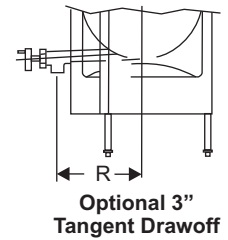
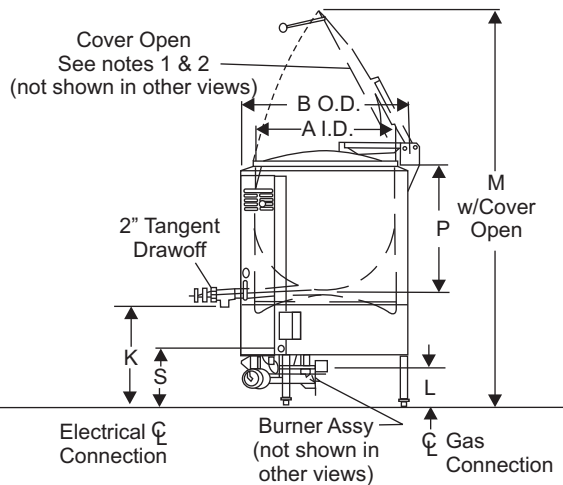
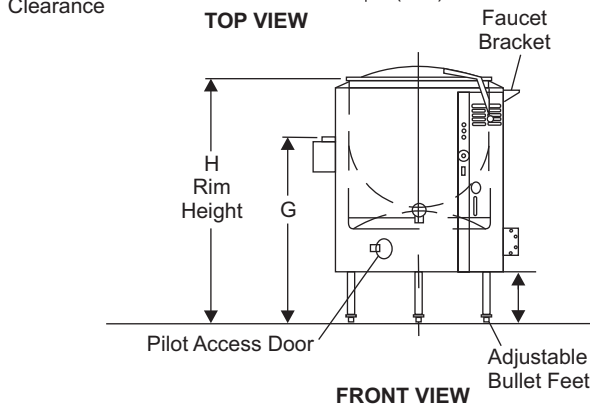
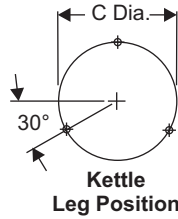
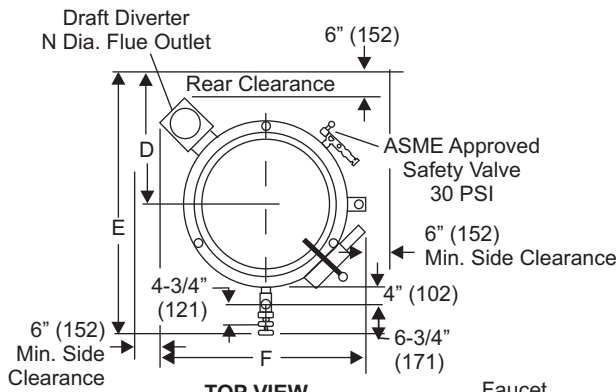

SHORT FORM SPECIFICATIONS

Provide Blodgett model 20G-KLS (20 gallon), 40G-KLS (40 gallon), 60G-KLS (60 gallon), 80G-KLS (80 gallon) or 10G-KLS (100 gallon) gas heated, stainless steel, steam jacketed kettle. Unit shall include 2" tangent draw-off valve, (3" optional) and No. 41 cover. 40 to 100 gallon units furnished with No. 51 spring assisted cover. Steam jacket is insulated and ASME code constructed for maximum working pressure of 30 PSI. Unit is thermostatically controlled, with electronic ignition standard. Requires 1/2" gas supply and 115 Volt electric service. Provide options and accessories as indicated.

MAXIMUM INPUT:

	Natural Gas	Propane
20G-KLS	85,000 BTU	85,000 BTU
40G-KLS	100,000 BTU	85,000 BTU
60G-KLS, 80G-KLS & 100G-KLS	145,000 BTU	145,000 BTU

GAS SUPPLY:

1/2" NPT connection required. A gas shut-off valve must be installed in supply piping convenient and adjacent to unit.

Inlet Pressure:

Natural	4.5" W.C. min, 14" W.C. max
Propane	11" W.C. min, 14" W.C. max

ELECTRICAL CONNECTION:

Requires one 115 Volt, single-phase, 60 HZ, 5 AMP supply.

SHIPPING INFORMATION:

Approx. Weight:

20G-KLS	468 lbs. (212 kg)
40G-KLS	620 lbs. (281 kg)
60G-KLS	885 lbs. (401 kg)
80G-KLS	1067 lbs. (484 kg)
100G-KLS	1135 lbs. (515 kg)

	20G-KLS	40G-KLS	60G-KLS	80G-KLS	100G-KLS
A	20 (508)	26 (660)	30 (762)	31.75 (806)	31.75 (806)
B	26.13 (664)	32.38 (822)	36 (914)	37.75 (959)	37.75 (959)
C	24 (610)	30.38 (772)	33.5 (851)	35.75 (908)	35.75 (908)
D	26.5 (673)	29.13 (740)	29.5 (749)	30.5 (775)	30.5 (775)
E	50.75 (1289)	56.25 (1429)	58.25 (1480)	61.25 (1556)	61.25 (1556)
F	39.5 (1003)	43.25 (1099)	46.25 (1175)	48 (1219)	48 (1219)
G	33.5 (851)	33 (838)	38.13 (968)	43.25 (1099)	43.25 (1099)
H	40 (1016)	41 (1041)	48.88 (1241)	56.5 (1435)	62.5 (1588)
J	9 (229)	9 (229)	11 (279)	11.5 (292)	11.5 (292)
K	18.5 (470)	16.75 (425)	21.38 (543)	24.25 (616)	24.25 (616)
L	6.75 (171)	6 (152)	6.13 (156)	8.5 (216)	8.5 (216)
M	73 (1854)	74.75 (1899)	76.63 (1946)	91.5 (2324)	97.5 (2477)
N	6 (152)	6 (152)	7 (178)	7 (178)	7 (178)
P	17.5 (445)	21.38 (543)	24.63 (625)	29.5 (749)	35.25 (895)
R	17.5 (445)	21 (533)	16.63 (422)	24.5 (622)	24.5 (622)
S	12 (305)	12 (305)	12 (305)	12 (305)	12 (305)

NOTE: The company reserves the right to make substitutions of components without prior notice.

BLODGETT

www.blodgett.com

44 Lakeside Avenue, Burlington, VT 05401 • Phone: (802) 658-6600 • Fax: (802) 864-0183