



Synergy Steam

6DS-KTT

Direct Steam Tabletop Tilting Kettle



Project \_\_\_\_\_

Item No. \_\_\_\_\_

Quantity \_\_\_\_\_

Model 6DS-KTT - 6 gallon (23 litres) direct steam table top tilting kettle

CONSTRUCTION

- 304 stainless steel, one-piece welded construction
- 2/3 jacketed kettle
- All exposed surfaces shall be stainless steel
- Sturdy cast, chrome plated stainless steel arms for sturdy support
- No exposed steam piping.
- Rim shall be reinforced with a welded butterfly shaped pouring lip, for pouring control and durability. Kettle can be emptied into an 8" high pan on a flat table.
- Handle for controlled pouring of kettle content. Two operating handle lugs so that the handle can be attached on right or left side
- Rear leg stops the kettle in the upright position
- ASME shop-inspected, stamped and registered with the National Board for operation up to a maximum working pressure of 55 PSI

STANDARD FEATURES

- One year parts and labor warranty\*

\* For all international markets, contact your local distributor.

6DS-KTT TABLETOP TILTING KETTLE

OPTIONS AND ACCESSORIES

(AT ADDITIONAL CHARGE)

- Basket inserts
- Lift off cover
- Steam trap assemblies
- 316 stainless steel interior
- Steam regulator



BLODGETT

www.blodgett.com

44 Lakeside Avenue, Burlington, VT 05401 • Phone: (802) 658-6600 • Fax: (802) 864-0183



# 6DS-KTT TABLETOP TILTING KETTLE



APPROVAL/STAMP

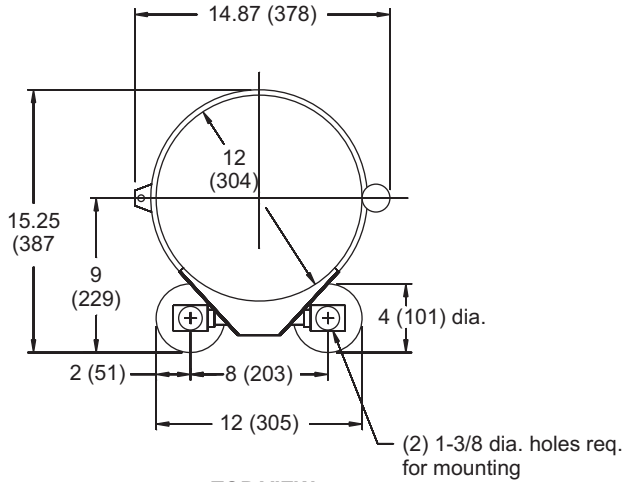

TOP VIEW

**NOTES:**

1. Extended stem. globe valve and collared sleeve furnished at extra cost.
2. Dimensions are in inches (mm).

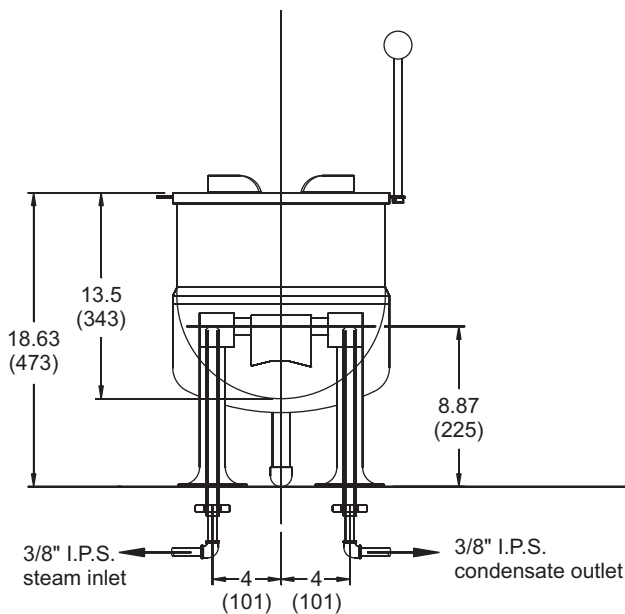

FRONT VIEW

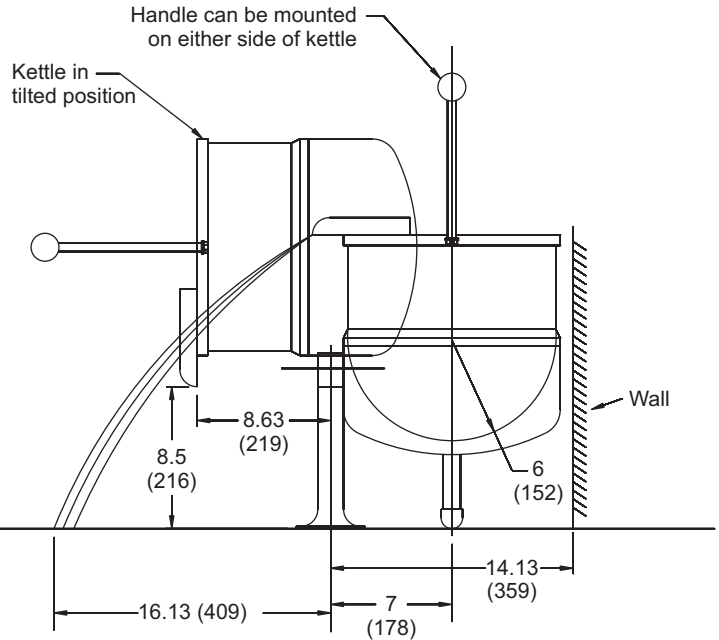

SIDE VIEW

**SHORT FORM SPECIFICATIONS**

Provide Blodgett model 6DS-KTT (6 gallon) direct steam tabletop tilting kettle. Unit shall have full bottom hemisphere steam jacket with one piece welded construction of Type 304 stainless steel, and sturdy tubular support arms. Reinforced bar rim, with butterfly shaped pouring lip standard. Lugs provided for use of handles on either side of unit. NSF listed, ASME code constructed and National Board registered. Operates dependably from 5 up to 55 PSI maximum. Steam and condensate connections required. Provide options and accessories as indicated.

**MAXIMUM PRESSURE:**

55 PSI (379 kPa) (optional higher working pressure is available)

**SHIPPING INFORMATION:**

**Approx. Weight:**  
6DS-KTT 45 lbs. (20 kg)

**NOTE:** The company reserves the right to make substitutions of components without prior notice.

**BLODGETT**

[www.blodgett.com](http://www.blodgett.com)

44 Lakeside Avenue, Burlington, VT 05401 • Phone: (802) 658-6600 • Fax: (802) 864-0183