



BTT-16G
Gas Table Top Tilting
Round Braising Pan



Shown with optional stand,
cover and faucet

OPTIONS AND ACCESSORIES

(AT ADDITIONAL CHARGE)

- Faucets
 - Single pantry faucet with swing spout
 - Double pantry faucet with swing spout
- Etched markings
 - Gallons
 - Litres
- 30" wide stainless steel stand with sliding drawer pan and stationary drain connection
- Steam pan insert
- Marine lock
- 220 VAC, 1 phase, 50/60 hz
- Lift off cover

Project _____

Item No. _____

Quantity _____

- Model BTT-16G (16 gallon gas tilting round braising pan)

CONSTRUCTION

- Satin finish 10 gauge stainless steel pan with polished interior
- Coved corners
- Pan slopes outward for easy access to cooking surface
- 3/8" thick stainless steel clad plate
- Stainless steel control housing
- Side pivots for tilting
- Tilting handle with heat proof knob
- Concealed mounting lugs for bolting unit to counter top

OPERATION

- Integrally mounted controls
- Ignition light
- Power switch
- Thermostat
- Cook indicator light
- High temperature cut-off
- 100-450°F (45-232°C) temperature range

CAPACITY

- 16 gallon (60 litres)

STANDARD FEATURES

- Side pivots and tilting handle
- Manual control
- Mounts to countertop (optional stand available)
- 30,000 BTU natural gas
- 115 VAC, 1 phase, 60 hz
- One year parts and labor warranty*

* For all international markets, contact your local distributor.

BTT-16G BRAISING PAN



BLODGETT

www.blodgett.com

44 Lakeside Avenue, Burlington, VT 05401 • Phone: (802) 658-6600 • Fax: (802) 864-0183



BTT-16G TABLE TOP TILTING ROUND BRAISING PAN

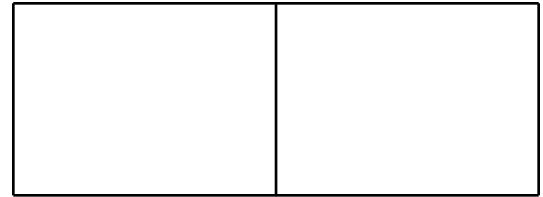

APPROVAL/STAMP

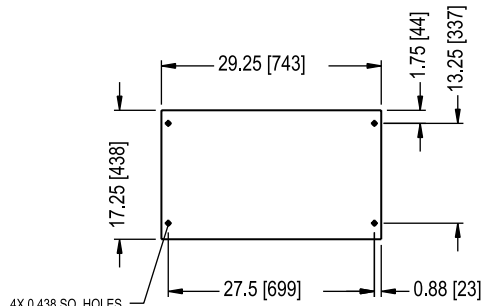
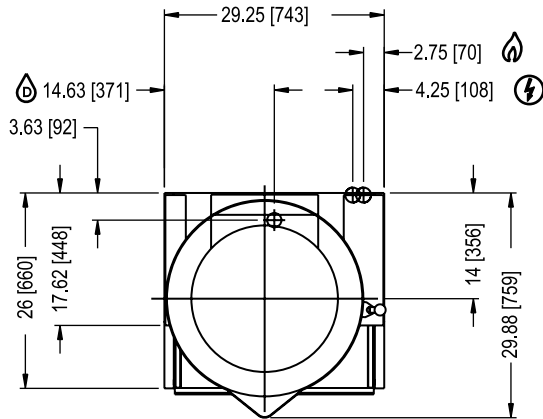

FRONT OF APPLIANCE
MOUNTING PATTERN

Shown with optional stand.
Dimensions are in inches [mm].

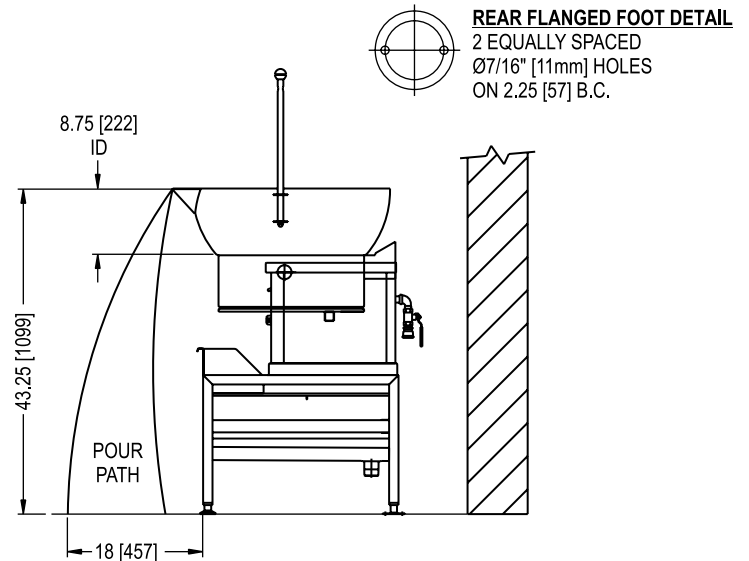
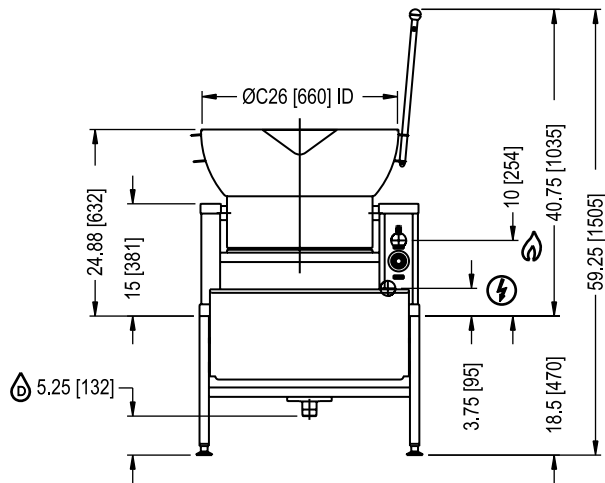

REAR FLANGED FOOT DETAIL
2 EQUALLY SPACED
Ø7/16 [11mm] HOLES
ON 2.25 [57] B.C.

SHORT FORM SPECIFICATIONS

Provide Blodgett model BTT-16G, 16 gallon (60 litre) gas fired counter round tilting braising pan. The unit shall have a one-piece covered corner, 10 gauge stainless steel pan with satin finish exterior and polished interior. The pan sides shall slope outward to facilitate access to the cooking surface which shall be a 3/8" thick stainless clad plate ensuring even heat transfer over entire cooking surface. The pan shall be mounted on side pivots to allow tilting for complete removal of contents by means of a tilting handle with heat proof knob. The controls shall be integrally mounted in the stainless steel housing and shall include a power switch, thermostat with range of 100-450°F (45-232°C), a cook indicator light, ignition light and high temperature cut-off. Provide options and accessories as indicated.

MAXIMUM INPUT:

BTT-16G 30,000 BTU/hr

GAS SUPPLY:

1/2" IPS supply line required

Minimum Inlet Pressure:

Natural 7.0" W.C. static to unit

POWER SUPPLY:

120VAC, 1 phase, 60 Hz., 2-wire w/ground
6' (1.8m) electric cord set furnished.

DRAIN CONNECTION (for optional stand):

1-1/4" (32mm) O.D. tube from tray pan.

SHIPPING INFORMATION:

Approx. Weight:

BTT-16G 250 lbs. (113 kg)

NOTE: The company reserves the right to make substitutions of components without prior notice.

BLODGETT

www.blodgett.com

44 Lakeside Avenue, Burlington, VT 05401 • Phone: (802) 658-6600 • Fax: (802) 864-0183