



# CTB XCEL Half-Size Electric Convection Oven



Shown on optional stand with casters

Project \_\_\_\_\_

Item No. \_\_\_\_\_

Quantity \_\_\_\_\_

Standard depth baking compartment - accepts 13" x 18" standard half-size baking pans in front-to-back-position. All data is shown per oven section, unless otherwise indicated.

Refer to operator manual specification chart for listed model names.

### EXTERIOR CONSTRUCTION

- Full angle-iron frame
- Stainless steel front, top and sides
- Dual pane thermal glass window encased in stainless steel door frame
- Single chrome plated door handle
- Stainless steel trim
- Tilt-down modular front control panel
- Solid mineral fiber insulation at top, back, sides and bottom

### INTERIOR CONSTRUCTION

- Double-sided porcelainized baking compartment liner (14 gauge)
- Five chrome-plated racks, nine rack positions with a minimum of 1-5/8" (41mm) spacing

### OPERATION

- Two tubular heaters (5kW)
- SmartTouch touchscreen control allows cooking with timer and core probe simultaneously. Includes shelf timing, cooking compensation and multi-shelf recipes. Holds up to 255 recipes.
- Two speed fan motor
- 1/2 horsepower blower motor with automatic thermal overload protection
- One control area cooling fan

### STANDARD FEATURES

- SmartTouch touchscreen control
- Three year oven parts and two year labor warranty\*
- Five year limited oven door warranty\*

\* For all international markets, contact your local distributor.

### OPTIONS AND ACCESSORIES

(AT ADDITIONAL CHARGE)

- **Legs/casters:**
  - 4" (102mm) legs (not for use with stands)
  - 6" (152mm) casters
- **Stands:**
  - 5-3/4" (146mm) stainless steel stand
  - 7" (178mm) stainless steel stand
  - 16" (406mm) stainless steel stand
  - 19" (438mm) stainless steel stand with shelf
  - 24" (610mm) stainless steel stand with shelf
  - 33" (838mm) stainless steel stand with shelf
  - 33" (838mm) stainless steel stand with shelf and rack guides
- Vent riser: stainless steel
- Cord set with receptacle
- 7.5 Kw elements
- Extra oven racks
- Oven Liner: Stainless steel





# CTB XCEL



APPROVAL/STAMP

TOP VIEW

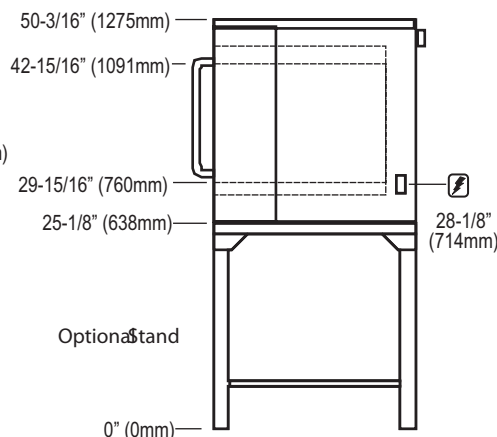
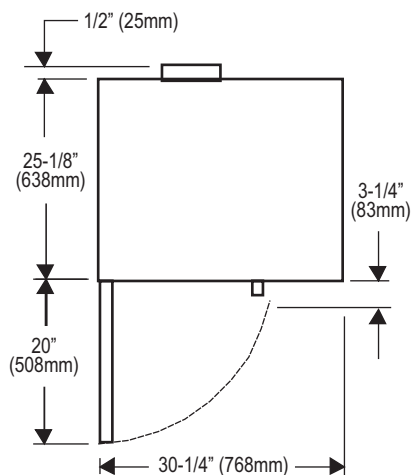

CTB/CTBR SINGLE

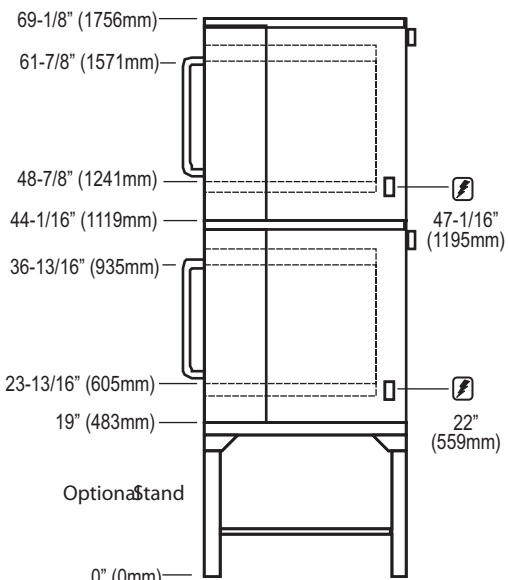

CTB/CTBR DOUBLE

**SHORT FORM SPECIFICATIONS:** Provide Blodgett half-size convection oven model CTB XCEL (single, double) compartment. Each compartment shall have (porcelainized/stainless) steel liner and shall accept five 13" x 18", standard half-size bake pans. Doors shall be (dual pane thermal glass/window/solid stainless steel door) with single chrome plated door handle. Stainless steel front, top, sides and legs. Unit shall be electrically heated with two or three tubular heaters dependent on wattage (5 or 7.5 kW) selection. Air in baking chamber distributed by blower wheel powered by two-speed, 1/2 horsepower motor with thermal overload protection. Each chamber shall be fitted with five chrome plated removable racks, and have nine rack positions. Control panel shall be recessed SmartTouch control allows cooking with timer and core probe simultaneously. Includes shelf timing, cooking compensation and multi-shelf recipes. Holds up to 255 recipes. Provide options and accessories as indicated.

**DIMENSIONS:**

Floor space	30-1/4" (768mm) W x 25-1/8" (638mm) D
Product clearance	0" from combustible and non-combustible construction.
Interior	15-1/4" (387mm) W x 20" (508mm) H x 21" (533mm) D

**MAXIMUM INPUT:**

Single	5.6KW (8.0 KW increase option available)
Double	11.2KW (16 KW increase option available)

**MINIMUM ENTRY CLEARANCE:**

Uncrated	25-1/16" (636mm)
Crated	30-1/4" (775mm)

**SHIPPING INFORMATION:**

**Approx. Weight:**

Single	295 lbs. (134 kg)
Double	595 lbs. (270 kg)

**Crate size:**

36" (914mm) L x 32" (813mm) W x 35" (889mm) H

**POWER SUPPLY:**

V.A.C.	Hz	Phase	K.W.H.	Amperes (L1-L2-L3)
<b>STANDARD</b>				
208	60	1	5.6	27/0/27
208	60	3	5.6	24/12/15
220-240	60	1	5.6	24/0/24
220-240	60	3	5.6	21/11/14
<b>INCREASED OUTPUT</b>				
208	60	1	8	35/0/35
208	60	3	8	22/20/21
220-240	60	1	8	32/0/32
220-240	60	3	8	20/18/19

1/2 H.P., 2 speed motor, 1120 and 1710 RPM (60Hz.)  
 1/2 H.P., 2 speed motor, 1440 and 930 (50Hz.)

**NOTE:** The company reserves the right to make substitutions of components without prior notice

**BLODGETT OVEN COMPANY**

www.blodgett.com • 44 Lakeside Avenue, Burlington, VT 05401 • Phone: (802) 658-6600 • Fax: (802) 864-0183