



MODEL DFG-200
Full-size Dual Flow Gas Convection Oven



OPTIONS AND ACCESSORIES

(AT ADDITIONAL CHARGE)

■ **Legs/casters/stands:**

- 4" (102mm) low profile casters (double only)
- 6" (152mm) seismic legs
- 6" (152mm) casters
- 25" (635mm) stainless steel open stand with rack guides

■ **Controls:**

- Solid state digital control with LED display, cook and hold, and Pulse Plus®
- Blodgett IQ2™ multi-stage programmable control
- SmartTouch touchscreen control allows cooking with timer and core probe simultaneously. Includes shelf timing, cooking compensation and multi-shelf recipes. Holds up to 255 recipes.

■ **Gas hose w/quick disconnect restraining dev**

■ **Gas hose with quick disconnect and restraining device:**

- 48" (1219mm) hose
- 36" (914mm) hose
- Black glass door with one piece curved stainless steel door handle. Inner glass is removable for easy cleaning between the panes.
- Controls on the left side
- Stainless steel oven liner
- Extra oven racks
- Solid stainless steel back
- Gas manifold (for double sections)
- Prison package (includes security control panel and stainless steel back)
- Security control panel
- Flue connector

OPTIONS AND ACCESSORIES

(AT NO ADDITIONAL CHARGE)

- Solid stainless steel doors

Project _____

Item No. _____

Quantity _____

Extra depth baking compartment - accepts five 18" x 26" standard full-size baking pans in left-to-right or front-to-back positions.

All data is shown per oven section, unless otherwise indicated.

Refer to operator manual specification chart for listed model name.

EXTERIOR CONSTRUCTION

- Full angle-iron frame
- Stainless steel front, top, and sides
- Dual pane thermal glass windows encased in stainless steel door frames
- Porcelain door handle with simultaneous door operation
- Triple-mounted pressure lock door design with turnbuckle assembly
- Modular slide out front control panel for easy access
- Solid mineral fiber insulation at top, back, sides and bottom

INTERIOR CONSTRUCTION

- Double-sided porcelainized baking compartment liner (14 gauge) for easy cleaning
- Aluminized steel combustion chamber
- Dual inlet blower wheel
- Five chrome-plated racks, eleven rack positions with a minimum of 1-5/8" (41 mm) spacing
- Interior lights

OPERATION

- Dual Flow Gas system combines direct and indirect heat
- Electronic spark ignition control system
- Removable dual tube burners
- Pressure regulator
- Manual gas service cut-off switch located on the front of the control panel
- Air mixers with adjustable air shutters
- Solid state thermostat with temperature control range of 200°F (93°C) to 500°F (260°C)
- Two speed fan motor (single speed in CE model)*
- 1/3 horsepower blower motor with automatic thermal overload protection
- Control area cooling fan
- Two 50 watt commercial bake oven lamps

STANDARD FEATURES

- Solid state manual control with digital timer
- 25" (635mm) adjustable stainless steel legs (for single units)
- 6" (152mm) adjustable stainless steel legs (for double sections)
- Draft diverter or draft hood for venting (select one)
- Two year parts and one year labor warranty
- Five year limited oven door warranty*

* For all international markets, contact your local distributor.



Intertek



BLODGETT OVEN COMPANY

www.blodgett.com

44 Lakeside Avenue, Burlington, VT 05401

Toll Free: (802) 658-6600 • Fax: (802) 864-0183

DFG-200



MODEL DFG-200



APPROVAL/STAMP

DIMENSIONS ARE IN INCHES (MM)

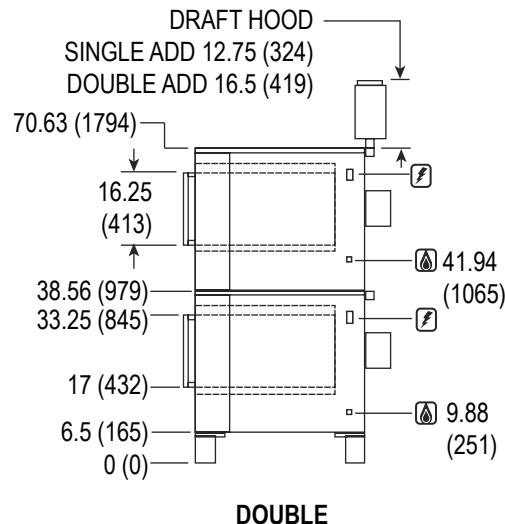
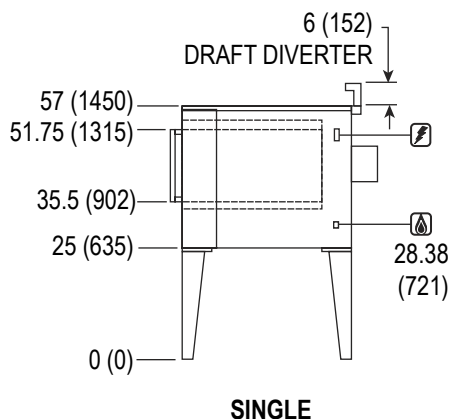
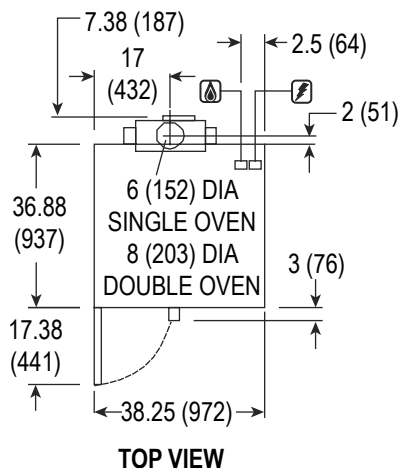

SHORT FORM SPECIFICATIONS

Provide Blodgett full-size convection oven model DFG-200, (single/double) compartment. Each compartment shall have (porcelainized/stainless) steel liner and shall accept five 18" x 26" standard full-size bake pans in left-to-right or front-to-back positions. Stainless steel front, top and sides. Doors shall (be solid stainless steel/have dual pane thermal glass windows) with single porcelain handle and simultaneous operation. Unit shall be gas heated with electronic spark ignition and shall cook by means of a dual-flow system combining direct and indirect heat with a gas shutoff switch on the front of the control panel. Air in baking chamber distributed by dual inlet blower wheel powered by a two-speed (single speed for CE model), 1/3 HP motor with thermal overload protection. Each chamber shall be fitted with two commercial lamps and five chrome-plated removable racks. Control panel shall be recessed with Cook/Cool Down mode selector, solid state (manual/digital) infinite thermostat (200- 500° F), and 60 minute timer. Provide twoyear parts and one year labor warranty. Provide options and accessories as indicated.

DIMENSIONS:

- Floor space** 38-1/4" (972mm) wide x 36-7/8" (936mm) long
- Product clearance** 6" from combustible and non-combustible construction.
- Interior** 29" (737mm) W x 20" (508mm) H x 28-1/4" (718mm) D
- If oven is on casters:**
 - Single Add 4-1/2" (114mm) to all height dimensions
 - Double All height dimensions remain the same
 - Double Low Profile Subtract 2-1/2" (64mm) from all height dimensions

GAS SUPPLY:

- 3/4" NPT (Single/Double)
- Manifold Pressure:
 - Natural – 3.5" W.C.
 - Propane – 10" W.C.
- Inlet Pressure:
 - Natural – 7.0" W.C. min. – 10.5" W.C. max.
 - Propane – 11.0" W.C. min. – 13.0" W.C. max.

MAXIMUM INPUT:

- Single 60,000 BTU/hr
- Double 120,000 BTU/hr (60,000 ea. section)

NOTE: The company reserves the right to make substitutions of components without prior notice

POWER SUPPLY

- 3-wire, 6 Amp, 115 VAC, 1 phase, 60 Hz. 1/3 H.P., 2 speed motor, 1140 and 1725 RPM
- 2-wire, 3 Amp, 220/240VAC, 1 phase, 50 Hz. 1/3 H.P., 1 speed motor, 1425 RPM
- 6' (1.8m) electric cord set furnished on 115 VAC ovens only.
- Blodgett recommends a Pass & Seymour, model 2095, GFCI for this oven.

MINIMUM ENTRY CLEARANCE:

- Uncrated 32-1/16" (814mm)
- Crated 37-1/2" (953mm)

SHIPPING INFORMATION:

- Approx. Weight:**
 - DFG-200 Single 565 lbs. (256 kg)
 - DFG-200 Double 1130 lbs. (512 kg)
- Crate sizes:**
 - 37-1/2" (952mm) x 43-1/2" (1105mm) x 51-3/4" (1315mm)

BLODGETT OVEN COMPANY

www.blodgett.com

44 Lakeside Avenue, Burlington, VT 05401 • Phone: (802) 658-6600 • Fax: (802) 864-0183