



# MARK V XCEL

## Full-Size Electric Convection Oven



Shown with optional SmartTouch control and optional 29" stand with casters

### OPTIONS AND ACCESSORIES

(AT ADDITIONAL CHARGE)

- **Control options:**
  - Digital control with Cook & Hold and Pulse Plus™
  - Digital control with Cook & Hold, Pulse Plus™, and Humidaire (stainless steel liner only)
  - Blodgett IQ2™ multi-stage programmable control
  - SmartTouch touchscreen control allows cooking with timer and core probe simultaneously. Includes shelf timing, cooking compensation and multi-shelf recipes. Holds up to 255 recipes.
- **Gas hose w/quick disconnect restraining dev**
- **Legs/casters/stands:**
  - 6" (152mm) adjustable seismic legs
  - 6" (152mm) casters
  - 4" (102mm) low profile casters (double only)
  - 25" (635mm) fully welded stand with adjustable, full-size rack guides
  - 29" (737mm) fully welded stand with pan supports and open storage
- Stainless steel oven liner
- Extra EZ slide oven racks
- Extra oven racks
- 440 volt, 3 phase
- 480 volt, 3 phase
- Prison package (includes security control panel and stainless steel back)
- Stainless steel solid back panel
- Security control panel

### OPTIONS AND ACCESSORIES

(AT NO CHARGE)

- Solid stainless steel doors

Project \_\_\_\_\_

Item No. \_\_\_\_\_

Quantity \_\_\_\_\_

Standard depth baking compartment - accepts five 18" x 26" standard full-size baking pans in left-to-right positions.

All data is shown per oven section, unless otherwise indicated.

Refer to operator manual specification chart for listed model name.

### EXTERIOR CONSTRUCTION

- Welded full angle-iron frame
- Rigid mineral fiber insulation at top, back and sides
- Stainless steel front, top, and sides for easy cleaning
- Dual pane black glass door provides larger viewing area. Inner glass is removeable for easy cleaning between the panes.
- Aesthetically pleasing one piece curved stainless steel door handle with simultaneous door operation
- Triple-mounted pressure lock door design with turnbuckle assembly
- Modular slide out front control panel for easy access

### INTERIOR CONSTRUCTION

- Double-sided porcelainized baking compartment liner (14 gauge) with coved corners for easy cleaning
- Aluminized blower wheel and motor mount
- Eleven rack positions with a minimum of 1-5/8" (41mm) spacing
- Bright halogen interior lights provide optimum visibility

### OPERATION

- Three tubular heaters
- Mercury free redundant mechanical heat contactor
- Solid state thermostat with temperature control range of 150°F (66°C) to 550°F (288°C)
- Two speed, 3/4 horsepower, convection motor with automatic thermal overload protection
- Control area cooling fan
- Breaker shut off switch on front panel for easy service

### STANDARD FEATURES

- Solid state manual control with separate dials to control thermostat and timer
- Porcelainized crumb pans collects cooking residues for easy oven cleaning.
- One chrome plated EZ-Slide rack with ball bearing slides capable of gliding completely out of the oven cavity. Heavy duty design holds up to 50 lbs.
- Four chrome-plated racks
- Vent connector (for double & additional sections)
- 25" (635mm) adjustable stainless steel legs (for single units)
- 6" (152mm) adjustable stainless steel legs (for double sections)
- Two year oven parts and one year labor warranty\*
- Five year limited oven door warranty\*

\* For all international markets, contact your local distributor.



### BLODGETT OVEN COMPANY

www.blodgett.com

44 Lakeside Avenue, Burlington, VT 05401

Phone: (802) 658-6600 • Fax: (802) 864-0183

MARK V XCEL



# MARK V XCEL



APPROVAL/STAMP

DIMENSIONS ARE IN INCHES (MM)

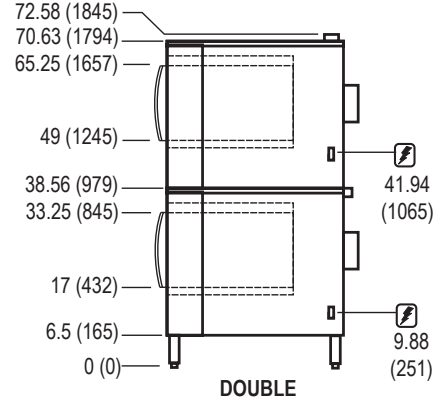
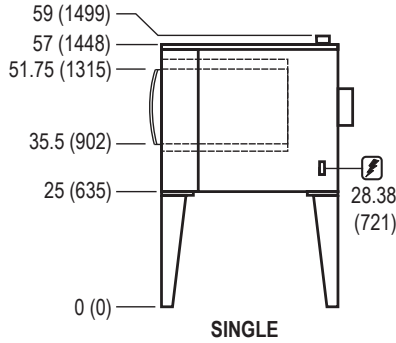
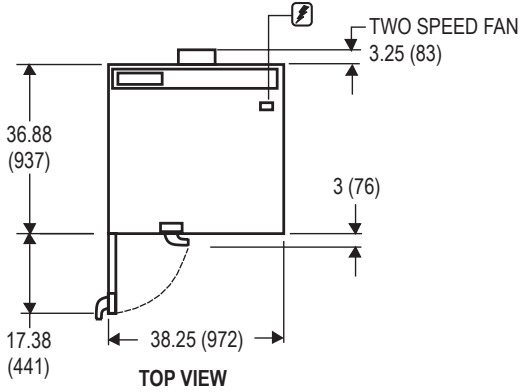

### SHORT FORM SPECIFICATIONS

Provide Blodgett full-size convection oven model Mark V XCEL, (single/double) compartment with fully welded angle iron frame. Each compartment shall have double-sided porcelainized or stainless steel liner. Liner to be covered top and bottom. Unit shall accept five 18" x 26" standard full-size bake pans. Doors shall be triple mounted, dual pane black glass door with larger viewing area. Inner glass is removeable for easy cleaning between the panes. Aesthetically pleasing one piece curved stainless steel door handle with simultaneous door operation. Unit shall be electrically heated with three tubular heaters. Air in baking chamber distributed by single inlet blower wheel powered by a two-speed, 3/4 HP motor with thermal overload protection. Each chamber shall be fitted with bright halogen lamps, one chrome-plated EZ slide racks capable of holding 50 lbs, four standard chrome-plated removable racks and a two piece porcelain crumb pan. Control panel shall be recessed with Cook/Cool Down mode selector, solid state (manual/digital) thermostat (150 - 550° F), (66-288°C) and 60-minute timer. Breaker shut off switch on front panel for easy service. Two year oven parts and one year labor warranty and five year limited oven door warranty. Provide options and accessories as indicated.

### DIMENSIONS:

**Floor space** 38-1/4" (972mm) W x 36-7/8" (937mm) D  
**Interior** 29" (737mm) W x 20" (508mm) H x 24-1/4" (616mm) D  
**If oven is on casters:**  
 Single Add 4-1/2" (114mm) to all height dimensions  
 Double Height dimensions remain the same  
 Double Low Profile Subtract 2.5" (64mm) from all height dimensions

### Product clearance

Oven sides 0" from combustible and non-combustible construction.  
 Oven back 0" from combustible and non-combustible construction.

### MINIMUM ENTRY CLEARANCE:

Uncrated 32-1/16" (814mm)  
 Crated 37-1/2" (953mm)

### SHIPPING INFORMATION:

#### Approx. Weight

Single 590 lbs. (268 kg)  
 Double 1145 lbs. (519 kg)

#### Crate sizes

37-1/2" (952mm) x 43-1/2" (1105mm) x 51-3/4" (1315mm)  
 (2 crates required for double)

**NOTE:** The company reserves the right to make substitutions of components without prior notice.

### MAXIMUM INPUT:

Single 11kW  
 Double 22kW (11kW each section)

### POWER SUPPLY:

V.A.C.	Hz	Phase	kW	Amperes (L1-L2-L3)
DOMESTIC				
208	60	1	11	53/0/53
208	60	3	11	33/28/33
220/240	60	1	11	50/0/50
220/240	60	3	11	28/23/28
440	60	3	11	16/13/16
480	60	3	11	15/12/15

3/4 H.P., 2 speed motor, 1140 and 1725 RPM (60Hz.)

### BLODGETT OVEN COMPANY

www.blodgett.com

44 Lakeside Avenue, Burlington, VT 05401 • Phone: (802) 658-6600 • Fax: (802) 864-0183