

## GENERAL INFORMATION

**Project Name:** \_\_\_\_\_  
**Item:** \_\_\_\_\_  
**Quantity:** \_\_\_\_\_  
**Model:** HTD-INF-NF  
**Length:** \_\_\_\_\_

## DESCRIPTION

BSI's HTD-INF-NF glass ceramic heated display combines European styling and elegance with excellent thermal conductivity to facilitate outstanding presentation and holding of hot food products.

The HTD-INF-NF is the ideal heated display solution for use on heat-sensitive counter tops. The extraordinary directional thermal properties of the glass ceramic surface transmit heat up through the top rather than out through all sides.

Heat is distributed evenly over the surface of the HTD-INF-NF. Surface temperatures of up to 250°F can be set and maintained through the infinite control. Heated displays are for pre-heated items only.

The HTD-INF-NF comes standard with the easily cleanable matte black ceramic top. The control box is attached with a 6' flexible conduit, with a 6' cord and plug Nema configuration at 5-15P. The flangeless models use a single bead of silicone. There is a seamless transition from the counter to the heated merchandiser.

BSI offers a variety of DECO™ TECH food shields and heat lamp accessories that can be matched with the HTD-INF-NF to create a complete portable solution to your heated food display needs.

## HTD-INF-NF

*Glass Ceramic Heated Drop-in Display (No Flange)*

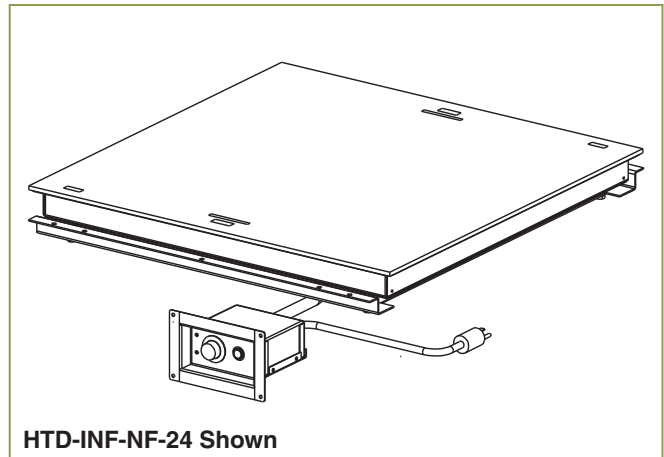

HTD-INF-NF-24 Shown

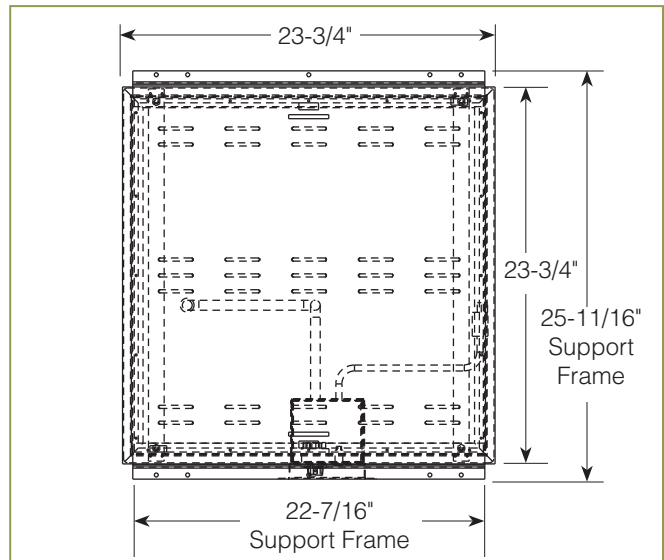

MODEL	HTD-INF-NF-24	HTD-INF-NF-36	HTD-INF-NF-48	HTD-INF-NF-60	HTD-INF-NF-72
<b>LENGTH</b> (cutout size)	23-3/4" (23-15/16")	35-3/4" (36-1/8")	47-1/2" (47-11/16")	59-1/2" (59-11/16")	71-1/2" (71-11/16")
<b>WIDTH</b> (cutout size)	23-3/4" (23-15/16")	23-3/4" (23-15/16")	23-3/4" (23-15/16")	23-3/4" (23-15/16")	23-3/4" (23-15/16")
<b>CONTROL BOX</b> (cutout size)	6-1/4" x 4" (5" x 2-3/4")	6-1/4" x 4" (5" x 2-3/4")	9-1/4" x 4" (8" x 2-3/4")	9-1/4" x 4" (8" x 2-3/4")	9-1/4" x 4" (8" x 2-3/4")
<b>ELECTRICAL SERVICES</b>	120V/3.94A	120V/6.12A	120V/7.88A	120V/10.06A	120V/12.24A
<b>NET WEIGHT</b>	40 lbs.	67 lbs.	102 lbs.	122 lbs.	157 lbs.
<b>SHIPPING WEIGHT</b>	62 lbs.	87 lbs.	122 lbs.	142 lbs.	177 lbs.

### \* Approval Drawings Required

Printed in the U.S.A. (January 2013) BSI, LLC  
 Specifications subject to change without notice.

Rv. 5

