

Camcarriers®

Top Loading

For GN Food Pans

Models 180MPC, 240MPC



Features & Benefits

- Rugged and dependable, these Camcarriers provide an exact fit for a variety of GN Full and Fractional Size Food Pans (Model 240MPC holds GN 1/2 Size Food Pans only).
- Create a wide variety of service configurations for food transporting using Cambro's GN Fractional Food Pans and 12" (32,5 cm) Divider Bars. Easily transforms the Camcarrier 180MPC into a mini food bar, salad bar or condiment station!
- GN 1/1 Full Size Food Pan capacity:
 - Model 180MPC - 1 each 8" (20 cm) deep
- GN 1/2 Size Food Pan capacity:
 - Model 240MPC - 1 each 2 1/2" (6,5 cm) or 4" (10 cm) deep
- One-piece seamless, double-wall, high-density polyethylene construction is durable, lightweight and dishwasher safe. Textured exterior is scratch resistant.
- Foamed-in polyethylene insulation and an airtight gasket helps to ensure excellent food temperature retention, hot or cold.
- Recessed vent cap located on the top is easily opened to help equalize pressure and release steam.
- Four each recessed plastic latches secure the lid tightly and will not rust or corrode and are protected from damage during use.
- Molded-in rim on all sides provides a comfortable grip for easy transporting.
- Securely stacks easily for more efficient transportation and storage. Model 180MPC also stacks with Ultra Pan Carriers® and S-Series Ultra Pan Carriers®.
- Optional Camdollies® provide easy transporting.
- Non-electrical.
- No assembly required.
- Available in 10 colors. Color variety offers quick food content identification and inventory control at-a-glance.

Item No. _____

Specifier Identification No. _____

Model No. _____

Quantity _____

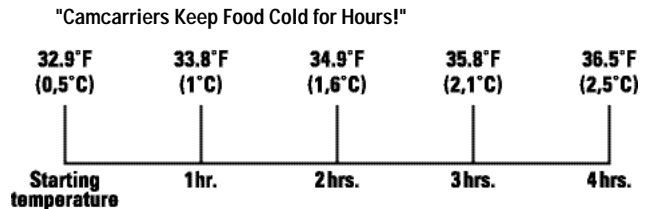
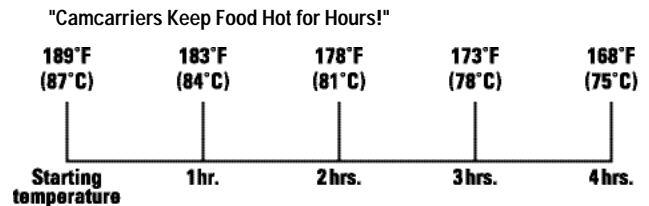

Approvals



Top Loading

For GN Food Pans

Models 180MPC, 240MPC

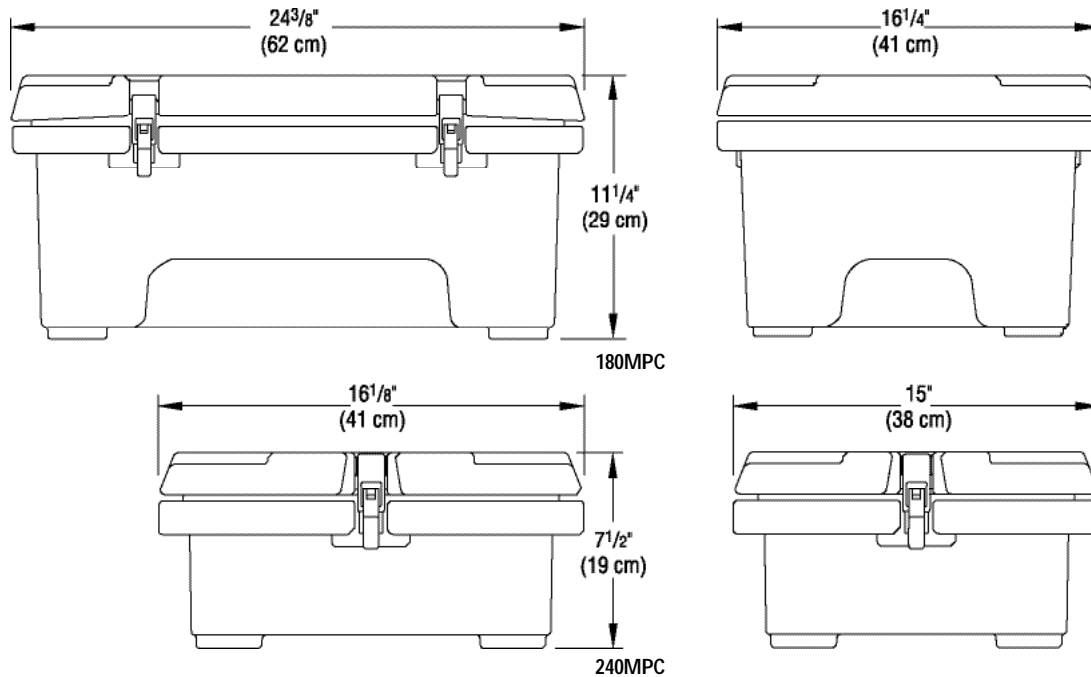

Specifications

Dimension Tolerance: +/- 1/4" (0,64 cm)

Code	Description	Approx. Capacity	Exterior Dimensions L x W x H	Case lbs./cube Kg/m ³
180MPC	Camcarrier	24.5 qts. (23 L)	24 3/8" x 16 1/4" x 11 1/4" (62 x 41 x 29 cm)	18.25 (2.79) 8 (0,085)
240MPC	Camcarrier (for 1/2 size pans only)	5.3 qts. (4,7 L)	16 1/8" x 15" x 7 1/2" (41 x 38 x 19 cm)	9.25 (1.20) 4,2 (0,034)

Optional Accessories

- Divider Bar**
- DIV12
 - White (148)
 - Clear (135)
- Camdolly®**
- CD160 for 180MPC

Standard Colors

- Dusty Rose (400)
- Navy Blue (186)
- Slate Blue (401)
- Cold Blue (159)
- Coffee Beige (157)
- Dark Brown (131)
- Brick Red (402)
- Green (519)
- Black (110)
- Hot Red (158)

Architect Specs

The portable non-electrical GN Food Pan transport carriers shall be Camcarriers, Models 180MPC and 240MPC, manufactured by Cambro Mfg. Co., Huntington Beach, CA 92648 U.S.A. It shall be made of one-piece, seamless, double-wall, high-density polyethylene and foam-injected polyurethane. It shall have a recessed vent cap on the outside top cover to help equalize pressure and release steam. It shall have an airtight gasket that is easily removable for cleaning. It shall be available to transport GN Full or Half or Fractional size Food Pans, 2 1/2", 4" and 8" (6,5; 10; and 20 cm) deep with DIV12 Divider Bars. It shall have 4 each recessed plastic latches. It shall have a molded-in rim on all sides for transporting. It shall have an interlock design on the bottom and top corners to provide secure stacking for transport and storage. The 180MPC model will stack with Ultra Pan Carriers and S-Series Ultra Pan Carriers. It shall be available to be transportable with optional Camdollies. It shall require no assembly and shall be available in 10 colors.

Approvals

