

Champion®

The Dishwashing Machine Specialists

Project _____
Item No. _____
Quantity _____

STANDARD FEATURES

- **ENERGY STAR® Qualified**
- 22" seamless prewash
- Chemical connections
- Built in diagnostics, for ease of service
- Energy Sentinel, for low water usage
- 219 racks per hour
- 130 gallons per hour/.59 gallons per rack (108 imp. gal per hour/.49 imp. gal per rack)
- Anti-jam conveyor system
- Extended stainless steel vent cowls with stack, dampers and extra curtain (set)
- Single point electrical connection
- Single point water connection
- 2 Hp wash pump motor
- Vent fan interlock connection
- Table limit switch connection
- Convenient top mounted controls
- Drain is a manual ball valve
- One year parts and labor warranty

OPTIONS & ACCESSORIES

- 40°F (4°C) rise (16 kW) electric booster
- 70°F (21°C) rise (27 kW) electric booster
- Direction of operation
 - Right to left
 - Left to right
- Table limit switch
- Drain water tempering kit (mounted and inter-wired)
- Voltage 480/60/3
- Water Pressure Reducing Valve (unmounted) (standard with booster)
- Cold water thermostat
- Shock arrester, unmounted

CH66

High Temperature Rack Conveyor Dishwashing Machine



CH66 shown with optional booster heater



SPECIFIER STATEMENT

Specified unit will be Champion CH66 rack conveyor dishwashing machine with 22" [559 mm] prewash.

Features include: chemical connections, vent fan interlock and table limit switch connections, energy sentinel, extended vent cowls with stack and dampers, built in diagnostics and anti-jam conveyor drive system.

1 year parts and labor warranty.

Champion Industries, Inc.
3765 Champion Blvd., Winston-Salem, NC 27105
Tel: 336/661-1556 Fax: 336/661-1979

www.championindustries.com

Champion[®]

The Dishwashing Machine Specialists

High Temperature Rack Conveyor Dishwashing Machine

Utilities	
1 Electrical	Machine and booster (See electrical chart)
2 Hot water	Main connection 3/4" NPT, 110°-140°F (43°-60°C) 20-22 PSI Flow pressure (124-152 kPA) PRV supplied with booster only
5 Drain Connection	1-1/2" NPT
8 Vent Stack Connection	A. Load end 150 CFM @ 1/4" static pressure B. Unload end 400 CFM @ 1/4" static pressure

Shipping weight crated: **1100 lbs. [454 kg]**

Dimensions shown in inches and [millimeters]

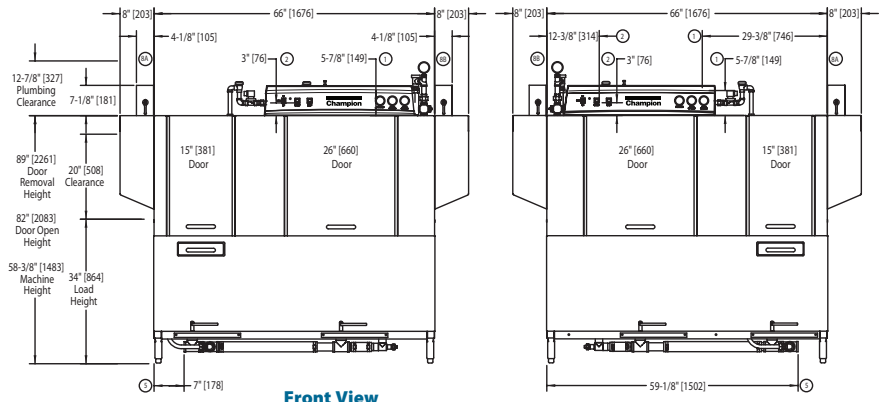

**Front View
Left to Right**

**Front View
Right to Left**

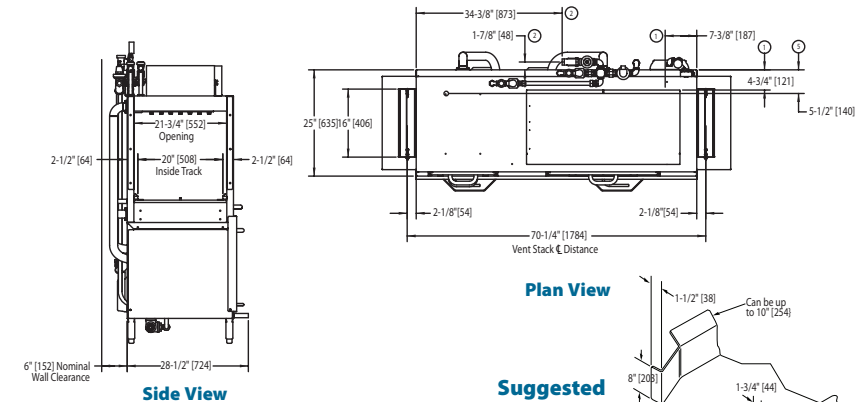

Side View

Plan View

**Suggested
Table
Construction**

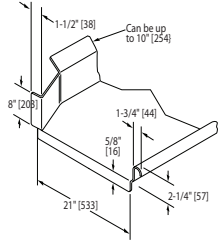

SPECIFICATIONS	
Capacity	
Racks per hr. (NSF rated)	219
Conveyor speed (ft/min)	6.0
Motor Horsepower	
Wash	2
Prewash	1
Water Consumption	
Per hr. (max. use)	130 US gal/ 108 imp.gal
Per rack	.59 US gal/.49 imp.gal
Heating	
Tank heat, electric (kW)	15
Electric booster (kW supplied for 40° F rise)	16
Electric booster (kW supplied for 70° F rise)	27

Warning: Plumbing and electrical connections should be made by qualified personnel who will observe all the applicable plumbing, sanitary and safety codes.

Machine only			
Elec. Specs.	Rate Amps	Maximum Supply Ckt. Conductor Ampacity	Maximum Overcurrent Protective Device
208/60/3	59	70	70
240/60/3	55	70	70
480/60/3	29	40	40

CH66 with 40° F Rise (16kW) Booster			
Elec. Specs.	Rate Amps	Maximum Supply Ckt. Conductor Ampacity	Maximum Overcurrent Protective Device
208/60/3	103	125	125
240/60/3	93	110	110
480/60/3	48	60	60

CH66 with 70° F Rise (27kW) Booster			
Elec. Specs.	Rate Amps	Maximum Supply Ckt. Conductor Ampacity	Maximum Overcurrent Protective Device
208/60/3	134	150	150
240/60/3	119	150	150
480/60/3	62	70	70

Booster Heater Only 40 F Rise, 16KW			
Elec. Specs.	Rate Amps	Maximum Supply Ckt. Conductor Ampacity	Maximum Overcurrent Protective Device
208/60/3	44	60	60
240/60/3	39	50	50
480/60/3	19	25	25

Booster Heater Only 70° F Rise, 27kW			
Elec. Specs.	Rate Amps	Maximum Supply Ckt. Conductor Ampacity	Maximum Overcurrent Protective Device
208/60/3	75	90	90
240/60/3	65	80	80
480/60/3	33	40	40

¹USGBC[®] and related logo is a trademark owned by the U.S. Green Building Council and is used by permission. Due to an ongoing value analysis program at Champion, specifications contained in this catalog are subject to change without notice.