

Champion[®]

The Dishwashing Machine Specialists

Project _____

Item No. _____

Quantity _____

DH5000 – VENTLESS HEAT RECOVERY MODEL (VHR)

STANDARD FEATURES

- ENERGY STAR[®] Qualified
- Steam and heat are collected and re-used.
- **NEW** Cold Water Feed only!
- The temperature of incoming cold water (3/4" NPT cold water line) is raised by heat produced during the cycle, then this water is fed to the booster
- 70°F rise booster standard
- No hood or canopy required
- Field convertible from three phase to single or from straight through to corner
- Bottom mounted digital controls (coloured LED zones and numbers)
- Standard and extended wash cycles
- Rinse sentry – ensures 180° final rinse



OPTIONS & ACCESSORIES

- Drain water tempering kit
- Flanged feet
- Racks
 - Peg
 - Flat

SPECIFIER STATEMENT – Ventless Heat Recovery Model

Specified unit shall be Champion model Genesis DH5000 **ventless heat recovery model** high-temperature hood-type dishwashing machine. Unit shall have a 3/4" cold water connection to be used for heat recovery and supply of 120°F to the built-in 70° rise booster.



GENESIS VENTLESS HEAT RECOVERY MODEL

GENESIS

DH5000 High Temperature Hood Type Dishwashing Machine

GENESIS

DH5000 High Temperature Hood-type Dishwashing Machine

Champion®

The Dishwashing Machine Specialists

Shipping weight crated: 350 lbs.

Dimensions shown in inches and [mm]

VENTLESS HEAT RECOVERY MODEL (VHR)

Removes heat and water vapor at the end of the cycle while recovering the normally exhausted heat and transferring it to the booster.

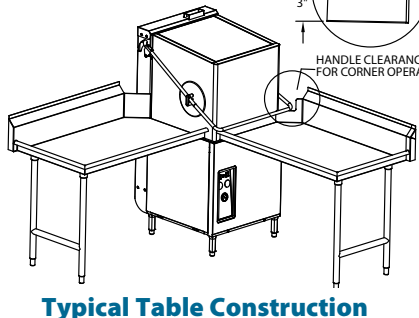
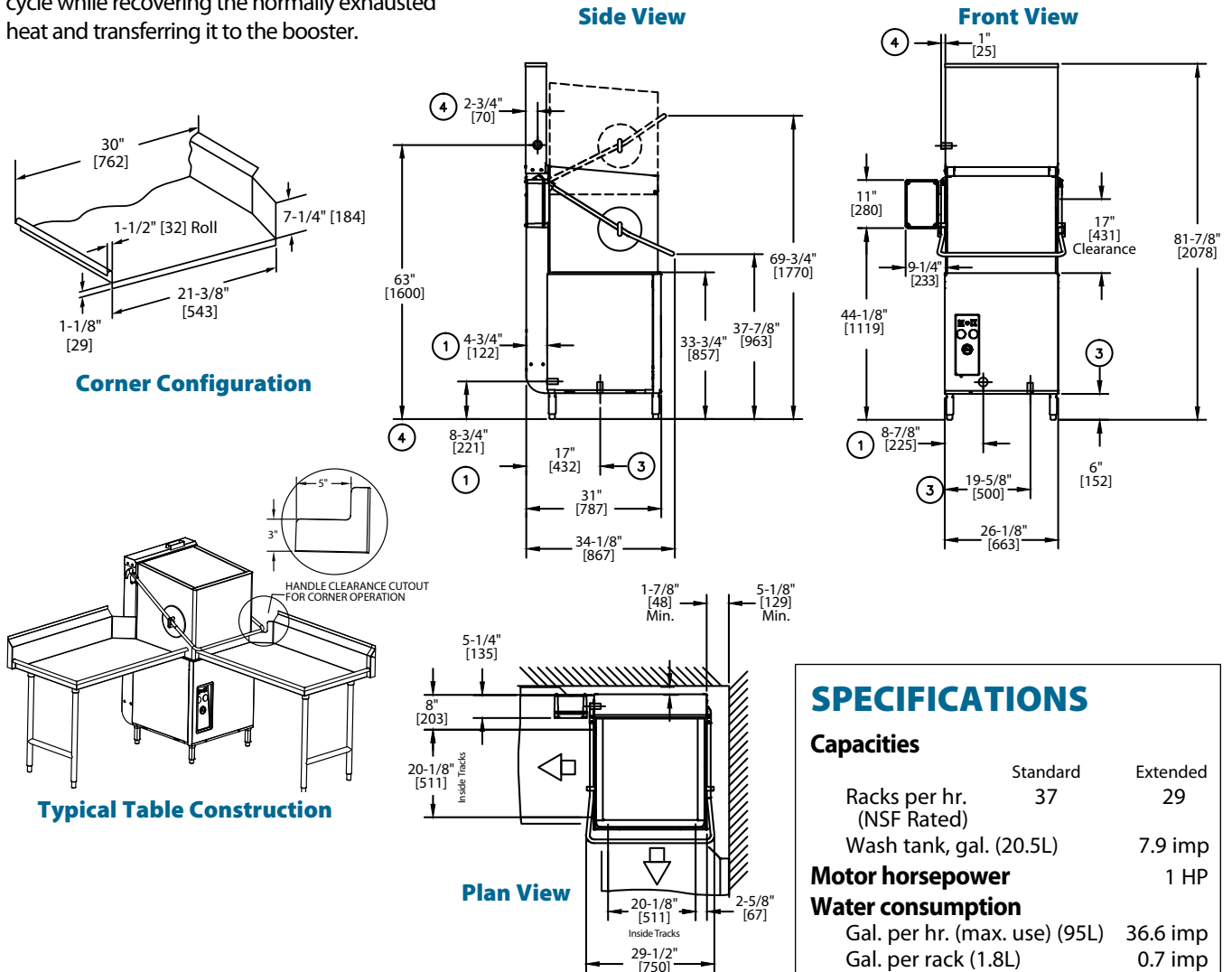

Utilities	
1	Electrical Machine Connection (See Electrical Box)
3	Drain 2" OD Connection [50mm] 12.5 imp gal max flow (56L)
4	Cold Water 3/4" NPT Cold Water 70°F (21°C) 40-45 PSI Flow pressure (machine operates at 20 PSI)

Warning: Plumbing, electrical connections should be made by qualified personnel who will observe all the applicable plumbing, sanitary and safety codes and the National Electrical Code.

Standard 70° Rise Booster			
Voltage	Rated Amps	Minimum Supply Ckt. Conductor Ampacity	Maximum Overcurrent Protective Device
208/60/1	79	100	100
240/60/1	90	100	100
208/60/3	48	60	60
240/60/3	54	60	60
480/60/3	22	25	25

SPECIFICATIONS		
Capacities		
Racks per hr. (NSF Rated)	Standard 37	Extended 29
Wash tank, gal. (20.5L)		7.9 imp
Motor horsepower 1 HP		
Water consumption		
Gal. per hr. (max. use) (95L)		36.6 imp
Gal. per rack (1.8L)		0.7 imp
Temperature °F/°C		
Wash		150/66
Rinse		180/82
Heating		
Tank heat, electric		5.2 kW
Electric Booster		10 kW
Time cycle in seconds		
	Standard	Extended
Wash	35	65
Rinse	10	10
Sanitary Dwell	15	15
Vent Fan	30	30
Total cycle	90	120

Due to an ongoing value analysis program at Champion, specifications contained in this catalog are subject to change without notice.