

# Champion®

The Dishwashing Machine Specialists

Project \_\_\_\_\_  
Item No. \_\_\_\_\_  
Quantity \_\_\_\_\_

P5-24 PULPER

## STANDARD FEATURES

- Flatware saver
- Flushing valve to pump-motor seal
- Flexible draw latches on hood assembly
- Remote mounted control box with overload indicator lights and circuit breaker
- Removable, gasketless water extractor door
- Start/stop switch mounted on extractor
- Stainless steel tubular bulletfeet legs
- 1-1/2" total adjustment
- Total stainless steel construction
- Water level control

## P5-24

5 Hp - 24" Pulper  
Waste Handling System



## OPTIONS & ACCESSORIES

- Anti-vibration feet for quieter operation
- Recirculating pump
- Multiple trough configurations
- Extractor flushing system
- Spray Reel - 30ft unmounted
- Automatic shutdown timer
- Deodorizer injector
- Remote mounted start-stop station (unmounted)
- Multiple trough sizes (9" & 12")

## SPECIFIER STATEMENT

Specified unit will be Champion model P5-24 pulper waste handling system.

Features include a standard feed tray, total stainless steel, free-standing close coupled waste handling system with a 24" diameter slurry chamber, 5 Hp grinding motor and 2 Hp extractor motor. Three stationary blocks with four cutting surfaces each, two tool steel rotating shearing blades, large water extractor chamber with removable gasketless door and external drain handle.

1 year parts and labor warranty.

Champion Industries, Inc.  
2674 N. Service Road,  
Jordan Station, Ontario, Canada L0R 1S0  
Tel: 800/263-5798 Fax: 905/562-4618

Champion Industries, Inc.  
P. O. Box 4149, Winston-Salem, NC 27115  
Tel: 336/661-1556 Fax: 336/661-1979  
[www.championindustries.com](http://www.championindustries.com)

## P5-24 PULPER

5 Hp - 24" Pulper  
Waste Handling System

### P5-24 with Optional Recirculating Pump Mounted on Rear of Water Extractor

Volume crated: **175. ft.**  
Shipping weight crated: **800 lbs.**

Dimensions shown in inches

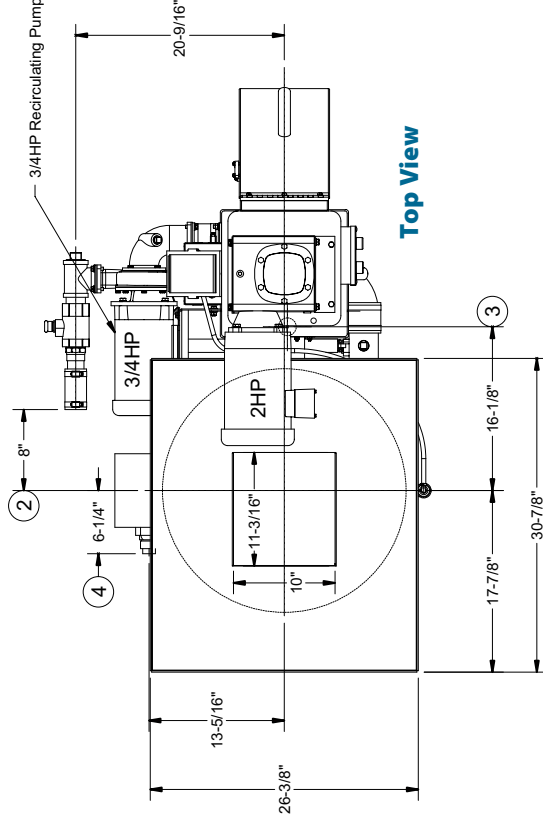
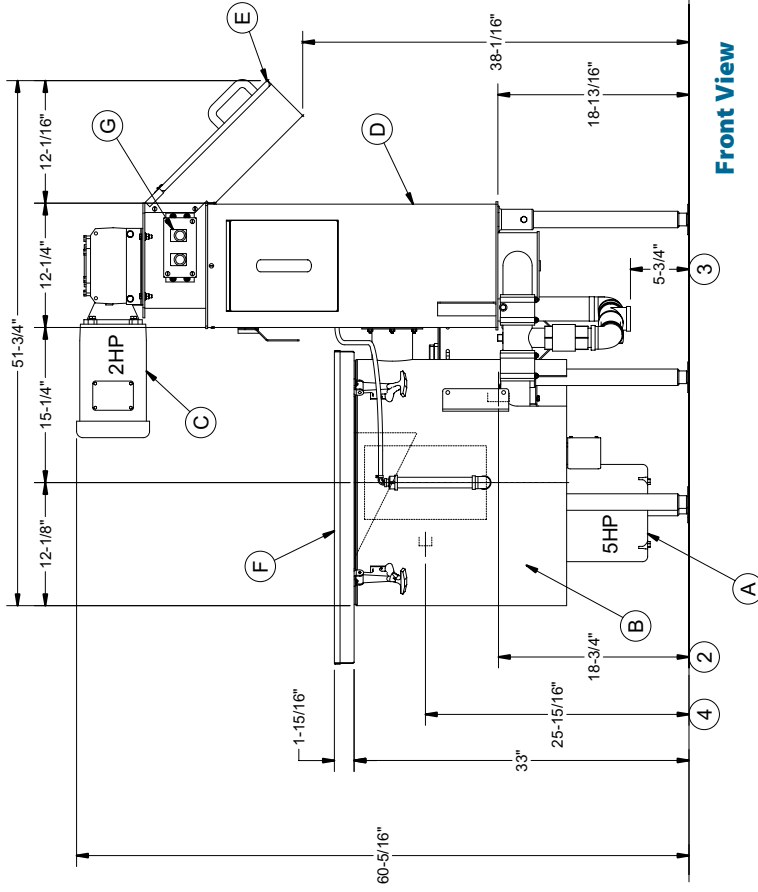

Top View

### SPECIFICATIONS

#### Capacities Input

Waste (approx. lbs. per hr.) 500

#### Motor horsepower

Pulper 5  
Water Extractor 2

#### Slurry Chamber

Tank (in. dia.) 24  
Cutting Disk (in. dia.) 12

#### Connections

Fresh water (in.) 1/2  
Drain (in.) 1-1/2

Item	Qty.	Description
A	1	Slurry Chamber 24" dia.
B	1	Motor-Main Drive 5 Hp
C	1	Water Extractor Drive Motor 2 Hp
D	1	Water Extractor
E	1	Discharge Chute
F	1	Scraping Tray
G	1	Start/Stop Station

#### Utilities

1	Electrical (see chart)
2	Optional Recirculation Pump
3	Drain 1-1/2" NPT
4	Cold water 1/2" NPT cold water connection

### P5-24 with Optional Recirculating Pump Mounted on Front of Water Extractor

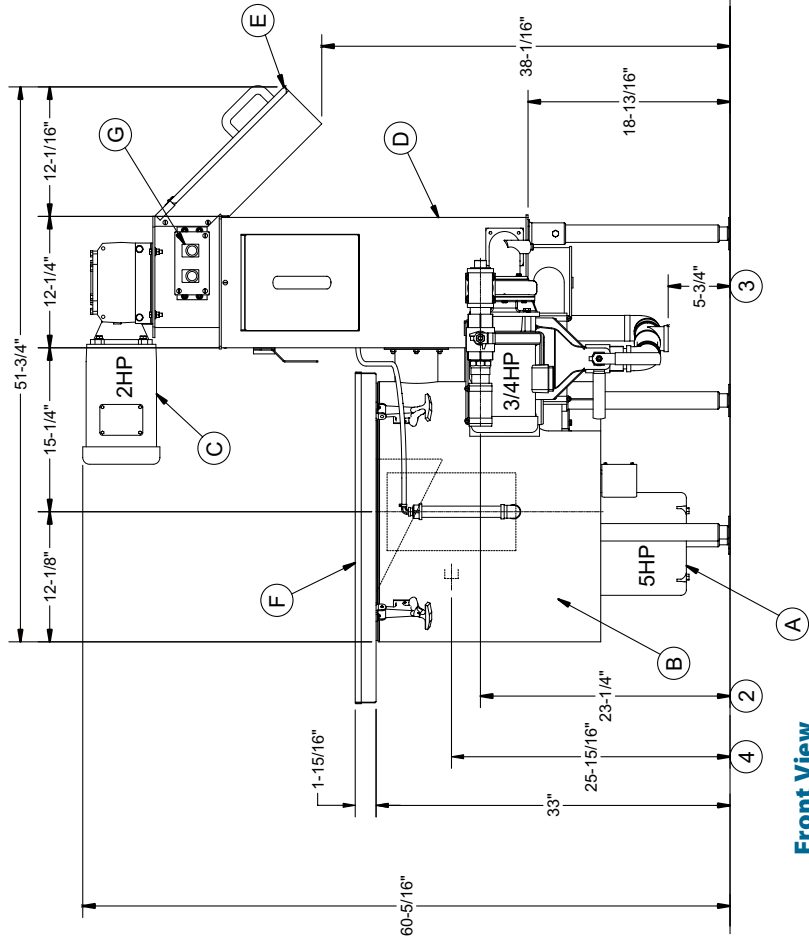

**Front View**

P5-24 w/ 3/4 Hp Recirculating Pump		Minimum Supply Ckt. Conductor Ampacity	Maximum Overcurrent Protective Device
Elec. Specs.	Rated Amps	40	40
208/60/3	31	40	40
230/60/3	29	40	40
460/60/3	14	20	20

P5-24 w/o Recirculating Pump		Minimum Supply Ckt. Conductor Ampacity	Maximum Overcurrent Protective Device
Elec. Specs.	Rated Amps	35	35
208/60/3	27	35	35
230/60/3	26	35	35
460/60/3	13	20	20

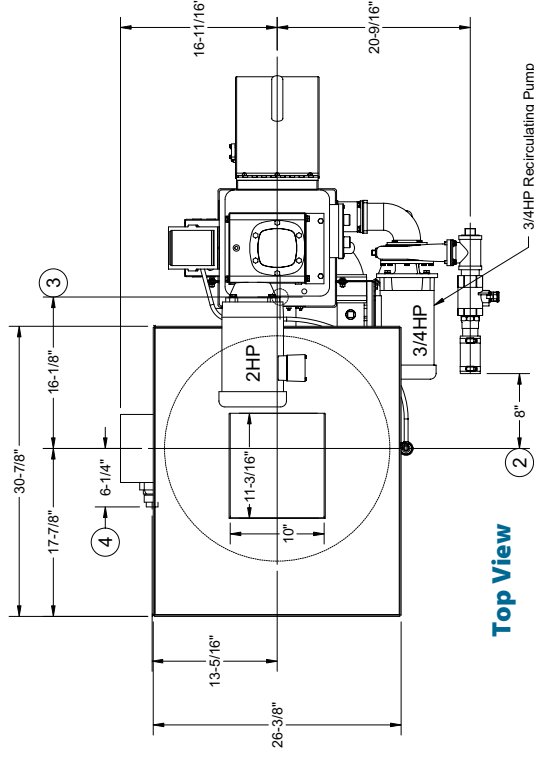

**Top View**

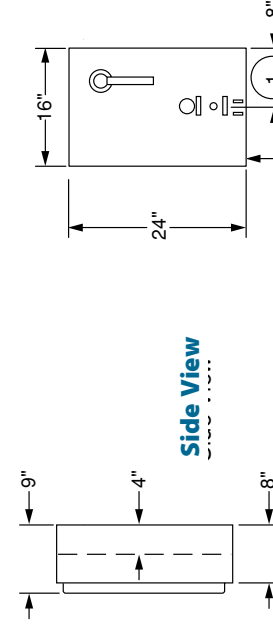

**Side View**

**Remote Mounted Control Cabinet**

48"

FLOORLINE

# P5-24

5 Hp - 24" Pulper  
Waste Handling System

# Champion®

The Dishwashing Machine Specialists

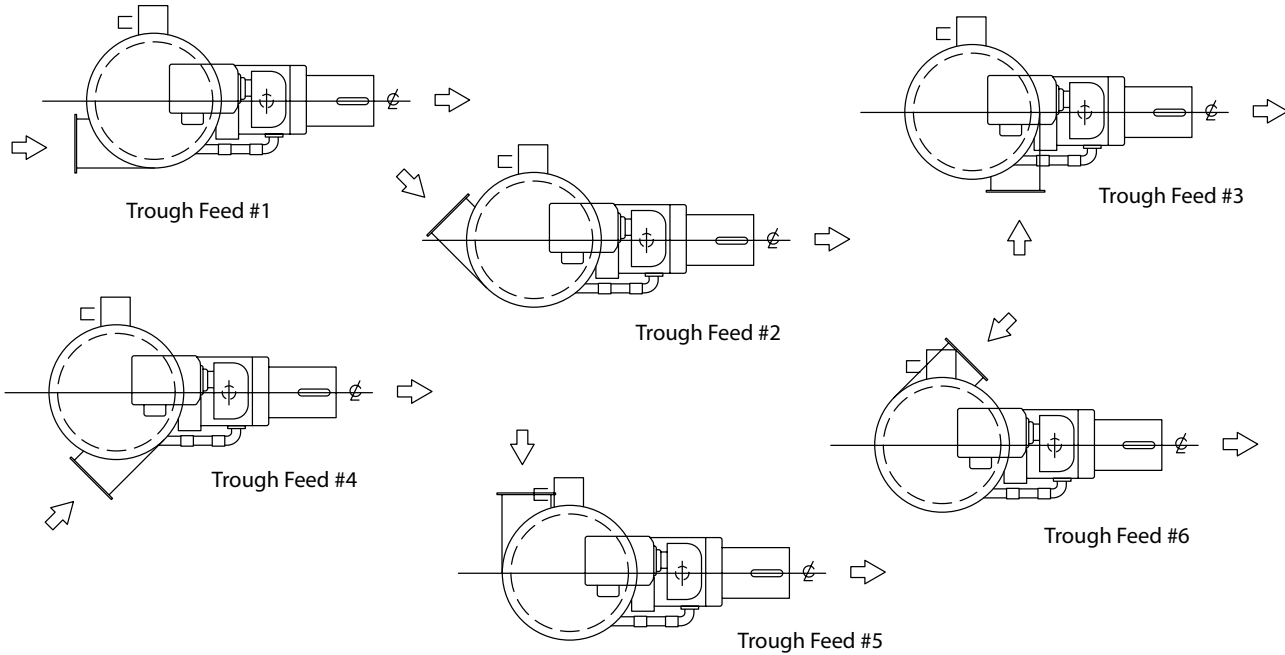

Feed Tray w/Hood

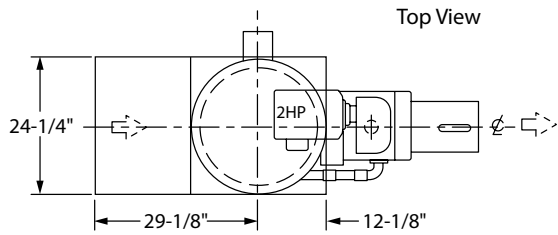

Under Table Feed Tray

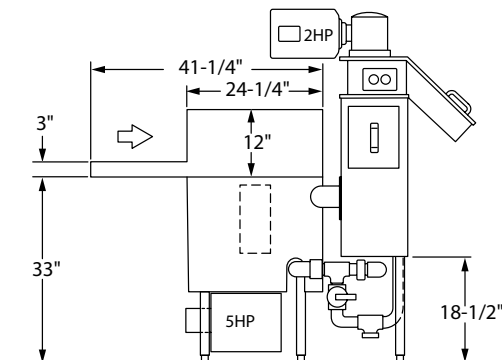
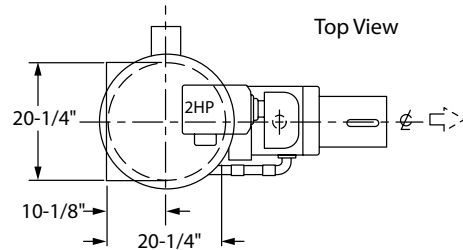

Front View

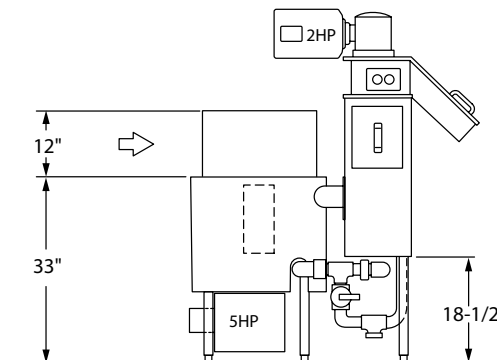

Front View

Due to an ongoing value analysis program at Champion, specifications contained in this catalog are subject to change without notice.  
 'USGBC' and related logo is a trademark owned by the U.S. Green Building Council and is used by permission.

Champion Industries, Inc., P. O. Box 4149, Winston-Salem, NC 27115 • 336/661-1556 • Fax: 336/661-1979 • www.championindustries.com  
 2674 N. Service Road, Jordan Station, Ontario, Canada L0R 1S0 • 800/263-5798 • Fax: 905/562-4618