

Champion[®]

The Dishwashing Machine Specialists

Project _____
Item No. _____
Quantity _____

STANDARD FEATURES

- Heavy-duty stainless steel construction
- Convenient drop-down door system
- Adjustable wash and rinse cycles
- External rinse hose and spray gun
- Self-contained water heating
- Moisture resistant control gauges
- Recirculating wash water
- Digital Control & Information Center
- Removable, dual filtration system
- Precision engineered spray patterns
- Versatile racking system
- One-year parts and labor warranty

MODEL UTM-10

Pot, Pan and
Utensil Washer



MODEL UTM-10 WASHER

OPTIONS

Additional Panwasher and Rackwasher Models:

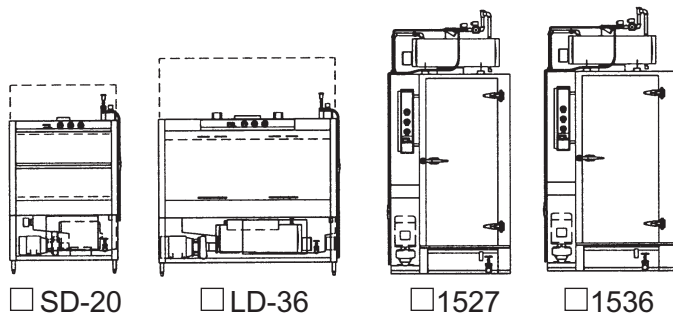

SD-20

LD-36

1527

1536

Champion Industries, Inc.
P. O. Box 4149, Winston-Salem, NC 27115
Tel: 336/661-1556 Fax: 336/661-1979
2674 N. Service Road,
Jordan Station, Ontario, Canada L0R 1S0
Tel: 905/562-4195 Fax: 905/562-4618

www.championindustries.com

MODEL UTM-10

Pot, Pan and Utensil Washer

Champion®

The Dishwashing Machine Specialists

Dimensions shown in inches

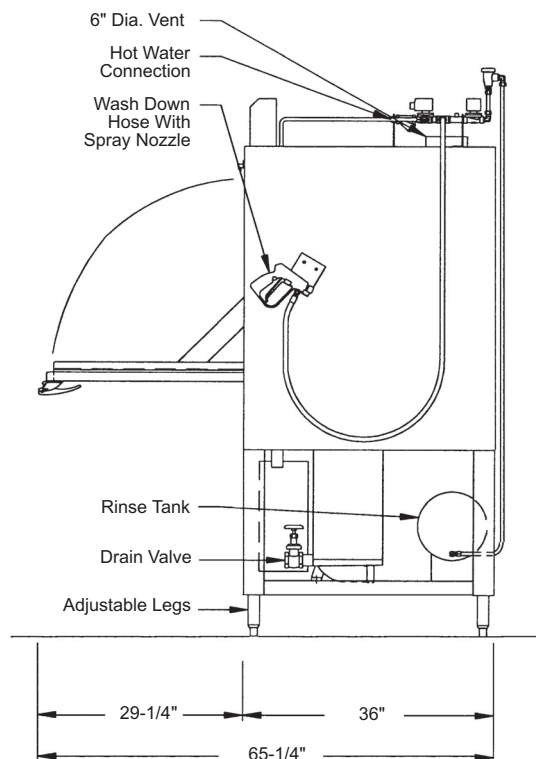
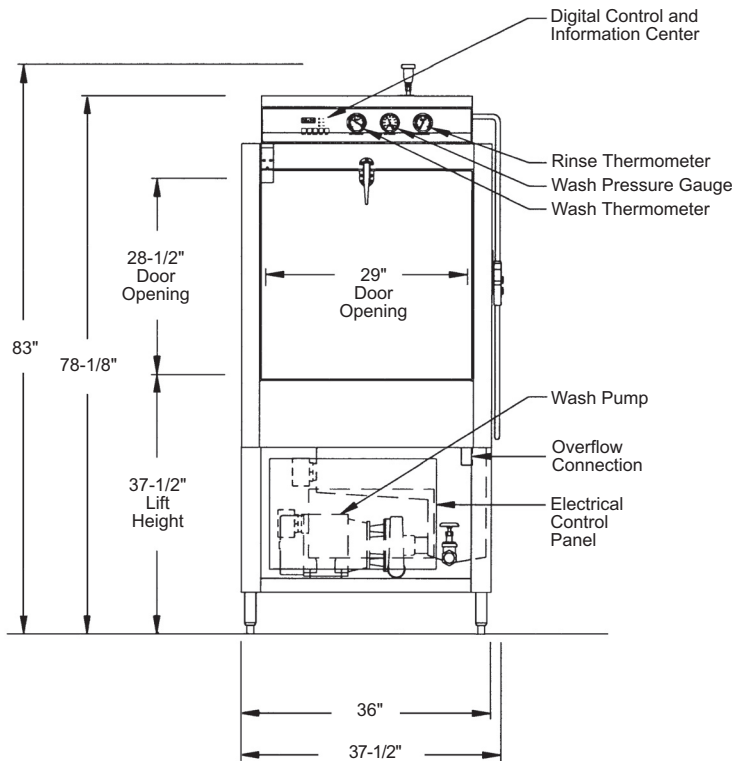

SPECIFICATIONS

Machine Construction

12, 14, & 16 gauge stainless steel.
All seams Heliarc welded.

Door

Stainless steel, drop-down door for easy loading and unloading.

Rinse Tank

Stainless Steel with electric, infrared gas or steam coil booster heater to provide 180°/190° hot sanitizing rinse. Uses 2.8 gallons per 22 second cycle.

Recirculating Wash Tank

Heated by one (1) 6 kW 208/240 at 480 volt electric immersion heater, thermostatically controlled wash temperature and low water protection system. 25 gallons, 14 gauge stainless steel, sloped to drain. Infrared gas and steam heating options available.

Filter

Perforated, removable, stainless steel baskets.

Water Pump

5 H.P., 208/240 or 440/480 volt, 1 phase or 3 phase, 60 cycle with output of 100 gallons per minute at 35 to 45 P.S.I.

Digital Control & Information Center

110 volt control circuit with push pad operation of "power on", "stop" and "short, medium or long wash cycles". A digital display indicates "time remaining" for each cycle. LED's indicate wash, rinse and unload functions. A buzzer is also included to provide an audible indication of time to unload. A pre-programmed circuit board allows the push pad to be used as a "diagnostic center" by displaying "error codes" for ease of troubleshooting.

Gauges

Special moisture resistant design. Wash temperature, rinse temperature, wash jet pressure.

Racks

Stainless Steel rod built to match specific washing requirements.

Due to an ongoing value analysis program at Champion, specifications contained in this catalog are subject to change without notice.

Champion Industries, Inc., P. O. Box 4149, Winston-Salem, NC 27115 • 336/661-1556 • Fax: 336/661-1979 • www.championindustries.com
2674 N. Service Road, Jordan Station, Ontario, Canada L0R 1S0 • 905/562-4195 • Fax: 905/562-4618

Washer	Automatic washing machine designed to wash all pots, pans and utensils commonly used in baking and cooking operations.
Cabinet	36" wide x 36" deep x 78-1/8" high. Clearance height: 83" (96-1/8" with optional infrared gas heated rinse tank). Door Opening: 29" wide x 28-1/2" high. Constructed of 12, 14 & 16 gauge, type 304 #3 finish, stainless steel. All seams tig-welded, cleaned and polished.
Door	Front-loading, hinged door design for easy loading and unloading. Door opens to create a convenient, space-saving drain table. Door is interlocked with limit switch to prevent machine operation while door is open. Door construction: 16 gauge, type 304 # finish, stainless steel.
Recirculating Wash Tank	Heated by one (1) 6 kW 208/240 at 480 volt electric immersion heater, thermostatically controlled wash temperature and low water protection system. 25 gallons, 14 gauge stainless steel, sloped to drain. Infrared gas and steam heating options available.
Wash Tank Filter	Perforated, stainless steel basket type designed for increased effectiveness and easy cleaning without emptying wash tank.
Wash Tank Fill Valve	Size 1/2" brass material, solenoid type, automatic.
Wash Tank Drain Valve	Size 1-1/4" brass material, gate type for manual or electrically operated ball valve for automatic option.
Optional Pumped Drain and Overflow	Automatic pump operation for elevated drain locations. Complete with 1/14 HP 120 volt 1 phase drain pump. Wash tank completely drains when power is turned off.
Wash Pump	5 Hp, 208/240 or 480 volt, 1 phase or 3 phase, 60 cycle. Close coupled; 100 gallons per minute at 35 to 45 psi, mounted on 12 gauge stainless steel formed channel base.
Rotating Wash Hub Assembly	Water driven, quick release, stainless steel jets, with removable end caps for quick and easy cleaning.
Sanitizing Rinse Tank	Stainless steel, 6 gallon capacity, with one (1) 6 Kw 208/240 or 480 volt electric booster heater to provide 180°/190° F hot sanitizing rinse. Uses 2.8 gallons per 22 second cycle. Infrared gas and steam coil heating options available.
Water Supply Valve	Size 1/2" brass material, solenoid type, automatic.
Final Rinse Piping	Type 304 stainless steel tubing with brass compression fittings and brass or optional stainless steel full cone rinse jets.
Control and Information Center	120 volt control circuit with push pad operation of "power on," "stop" and "short, medium or long wash cycles." A digital display indicates "time remaining" for each cycle. LED's indicate wash, rinse and unload functions. A buzzer is also included to provide an audible indication of time to unload. A pre-programmed circuit board allows the push pad to be used as a "diagnostic center" by displaying "error codes" for ease of troubleshooting. Moisture resistant gauges measure Wash Temperature, Wash Pressure and Rinse Temperature.
Wash Down Spray Hose	Externally mounted rinse hose with spray gun for easy cleaning and maintenance of machine.



The Dishwashing Machine Specialists

SPECIFICATIONS

MODEL UTM-10 POT, PAN & UTENSIL WASHER

- Steam Exhaust Vent** Steam exhaust vent 6-5/8" diameter, consisting of 16 gauge rolled collar for PVC pipe connection bolted to the top of the machine. Machine pre-wired with control timer for the addition of a fan.
- Optional Exhaust Fan** Draft inducer fan, side mounted on exhaust duct to extract excess steam after final rinse cycle. 300 CFM @.05" static pressure. 1/10 HP, 110 volt motor, 1550 RPM.
- Racks** Customized to hold your specific items. Standard bakery racks include utensil basket with hold-down lid and bun/sheet pan insert designed to hold ten pans, constructed of STAINLESS STEEL rod, tig welded.
- Connections** Water Inlet: 120°F, 3/4" NPT
Water Drain and Overflow: 1-1/4" NPT
Electrical: Two point connection through knock out on electrical enclosure.
Steam Heating Option: 1/2" NPT
Natural or Propane Gas Heating Option: 1/2" NPT.
- Weight** Crated: 850 lbs. Uncrated: 600 lbs.
NOTE: All weights are approximate. Weights will vary depending on the number of options included with the machine.
- Services** 120 Volt -1 phase, 5 running amps, 15 amp service, plus one of the following:

	Running Amps		
	Electric Wash Electric Booster	Steam Wash ¹ Steam Booster	Infrared Gas Wash ² Infrared Gas Booster
208 Volt 3 phase	46	13	13
240 Volt 1 phase	72	22	22
240 Volt 3 phase	42	12	12
480 Volt 3 phase	21	6	6

¹ Steam Supply: Consumption: 61 lbs./hr. @ 15 psi minimum

² Gas Supply: Consumption: 60,000 BTU/hr. @ 1/2 lb. pressure maximum

Certifications UL and UL Sanitation Listed (all). CUL Listed (electric and steam only).

