

MODULAR BASE WITH KETTLES

200M or 300M BTU GAS-FIRED STEAM GENERATOR with NICKELGUARD™
 ONE 6 GALLON KETTLE AND ONE 12 GALLON KETTLE
 CABINET BASE: 42" (1050MM) WIDE

MODELS: 42-GM-K612-200
 42-GM-K612-300

Cleveland Standard Features

- Factory assembled Kettle/Steam Generator NickleGard Base combination with one 6 gallon kettle and one 12 gallon kettle with 200M or 300M BTU Gas-Fired Steam Generator
- Solid State steam generator Water Level Controls
- Low Water Safety Cut-Off
- Pressure Limit Controls with 15 psi Safety Valve
- Type 430 Stainless Steel exterior enclosure, and table top (with Drain Trough which has 1.50" diameter male drain), #4 exterior finish
- Type 304 Stainless kettles, #4 exterior finish
- Separate "Start/Reset" Illuminated Switch Controls, plus Pressure Gauge
- Solid State Electronic Spark Ignition for energy savings
- Major components serviceable from the front of the unit
- 6 and 12 gallon kettles are 2/3 Steam Jacketed and include Lift-off Covers
- Hot and Cold Water Faucet with Swing Spout
- Kettles have 50 psi Steam Jacket Rating, 50 psi chrome plated Safety Valves and Manual Tilting, balanced design
- Tilt Handles can be mounted on either side
- Steam Generator empties under pressure (blowdown) automatically upon each Shut-Down, Automatic Water Refill on Start-Up
- Standard voltage for controls is 115 volt, 60 Hz, single phase
- Adjustable Flanged Feet (FF-A)
- Secondary Low Water Cut-Off, factory installed (CALG)
(Required for AZ. AR. CA. CO. CT. DE. FL. GA. HI. IL. IA. KS. MD. MA. MI. MN. MT. NE. NV. NM. NC. OK. OR. PR. RI. TN. UT. VA. WA. WV., Buffalo, NY, Wash. DC)



Short Form Specifications

Shall be CLEVELAND, Modular Cabinet Base with one 6 gallon kettle and one 12 gallon kettle, Model 42-GM-K612-____, 200M or 300M BTU Nickelguard Gas-Fired Steam Generator, type 430 Stainless Steel exterior enclosure, Table Top, Back Splash and 4 level adjustable feet. 2/3 Steam Jacketed type 304 Stainless Steel kettles with 50 psi Steam Jacket Rating; needle type Steam Control Valve on each kettle. Console mounted Controls, Pressure Gauge and Illuminated "Start/Reset" Control Switches. Solid State Water Level Steam Generator Controls and Electronic Spark Ignition. Steam Generator drains under pressure (blowdown) after each Shut-Down with Automatic Water Refill on Start-Up. 15 psi Safety Valve

Options & Accessories

- Power Take-Off Kit (GPTO)
- Gas, other than natural
- Type 316 Stainless Steel kettle interior for high acid food products (316)
- Food Strainers (FS)
- Stainless Steel Base Frame (FSS)
- Boiler Descaling Pump Kit (107142)

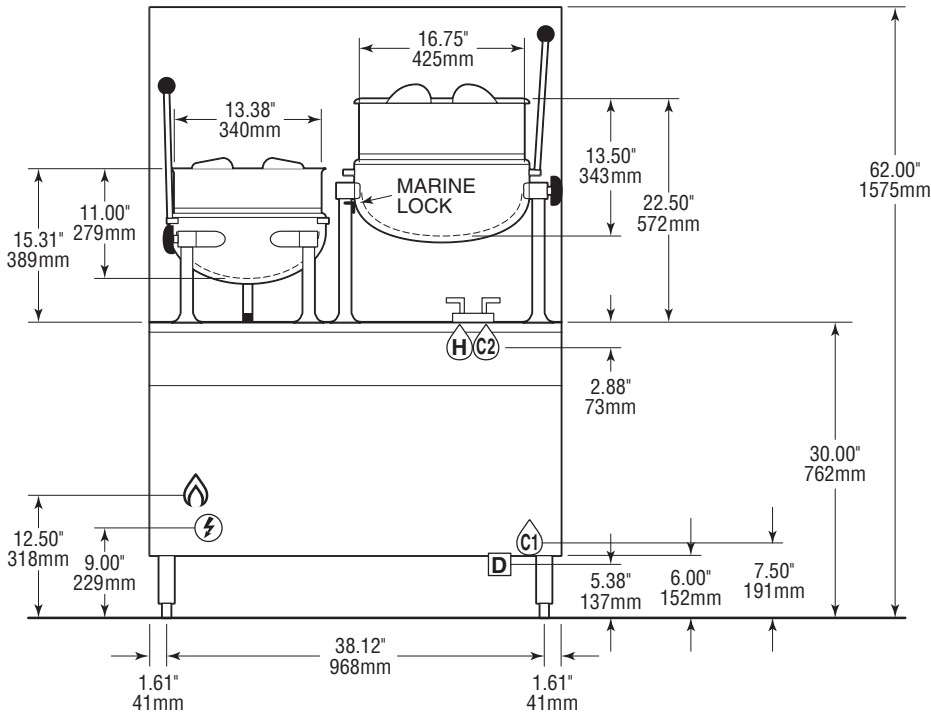
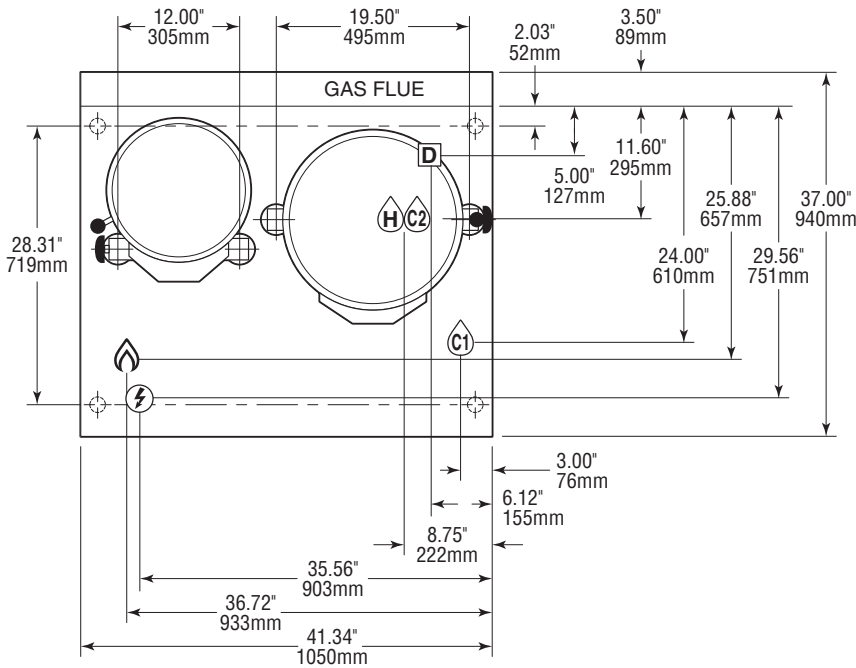

GAS 🔥

NATURAL
 3/4" IPS for 200,000
 1.00" IPS for 300,000
 Supply Pressure
 4.00" W.C. Minimum
 14.00" W.C. Maximum

PROPANE
 3/4" IPS for 200,000
 1.00" IPS for 300,000
 Supply Pressure
 12.00" W.C. Minimum
 14.00" W.C. Maximum

WATER QUALITY REQUIREMENT

The recommended minimum water quality standards whether untreated or pre-treated, based upon 10 hours of use per day, and a Daily Blowdown, are as follows:

- TOTAL DISSOLVED SOLIDS**
less than 60 parts per million
- TOTAL ALKALINITY**
less than 20 parts per million
- SILICA**
less than 13 parts per million
- pH FACTOR**
greater than 7.5
- CHLORINE**
less than 30 parts per million

Consult a local water treatment specialist for an on site water analysis for recommendations concerning steam generator feed water treatment (if required), in order to remove or reduce harmful concentrations of minerals. The use of highly mineralized water will mean that more frequent servicing of the steam generator will be necessary. The fact that a water supply is potable is not proof that it will be suitable for the generator.

CAPACITIES: (in 4 oz. servings, other sizes may be calculated.)

- 6 Gallon / 23 liters160 servings
- 12 Gallon / 45 liters352 servings

ELECTRIC ⚡

50 watts for generator
 115 V-1 PH
 ** Do not connect to GFI outlet. See note below.

WATER 💧💧

C1: 1/4" IPS Cold water for boiler
 C2: 3/8" NPT Cold water for faucet
 C2: 3/8" NPT Hot water for faucet

DRAIN 🗑️

1 1/2" IPS Common Drain
 The floor drain must be located outside the confines of the equipment.
 Do not connect to any other drain.

CLEARANCES

Right: 6.00"
 Left: 6.00"
 Rear: 6.00"

NOTES:

**DO NOT CONNECT TO GFI OUTLET. CLEVELAND RANGE RECOMMENDS GAS FIRED 120 VOLT STEAMERS BE HARD WIRED DIRECTLY TO ELECTRICAL SYSTEM.
 Cleveland Range reserves right of design improvement or modification, as warranted.
 Many regional, state and local codes exist and it is the responsibility of the owner and installer to comply with the codes.
 Cleveland Range equipment is built to comply with applicable standards for manufacturers. Included among those approval agencies are ASME/N. Bd, UL/NSF#4 and CSA (AGA, CGA).