



**34" EQUIPMENT STAND OPEN TYPE STAND,  
ALL STAINLESS STEEL CONSTRUCTION**

***Cleveland Standard Features***

- Cups provided for securing MINI legs into proper position and accomodating utilities
- All stainless steel welded construction with 1 1/4" square tubing
- Stationary shelf provided at bottom of stand
- Adjustable feet (rear feet are flanged for floor bolting)

**Note:** Not indended for stacking units.

***Options & Accessories***

- Pull-Out Shelf Kit (111724)
- Pan Rack Kit (111726)
- Stainless Steel Wire Shelves (WS5)
- Stainless Steel Perforated Cafeteria Pans (PP)
- Stainless Steel Solid Cafeteria Pans (SP)

**MODEL:**  CST3100B

Only used for MINI model OES310.



Shown with optional  
Pull-Out Shelf Kit  
and Pan Rack Kit.

***Short Form Specifications***

*Shall be a Cleveland 34" high Equipment Stand CST3100B with: Cups provided for securing unit into proper position and accomodating utilities; All stainless steel welded construction with 1 1/4" square tubing; Stationary shelf at bottom of stand; Adjustable feet (rear feet are flanged for floor bolting).*

# CST310OB MINI EQUIPMENT STAND

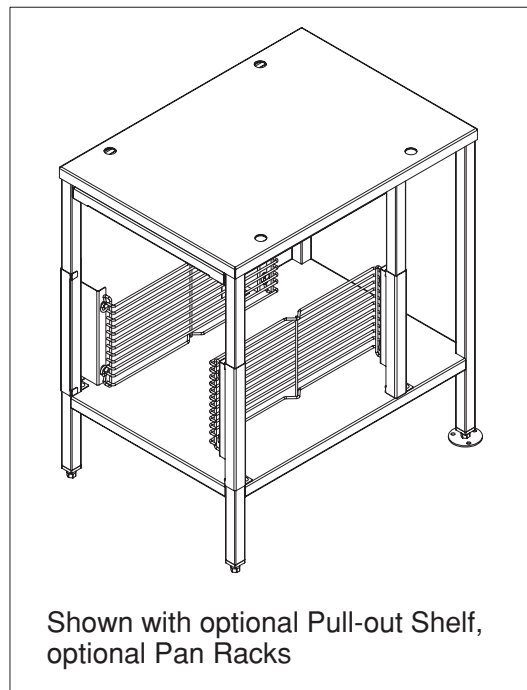
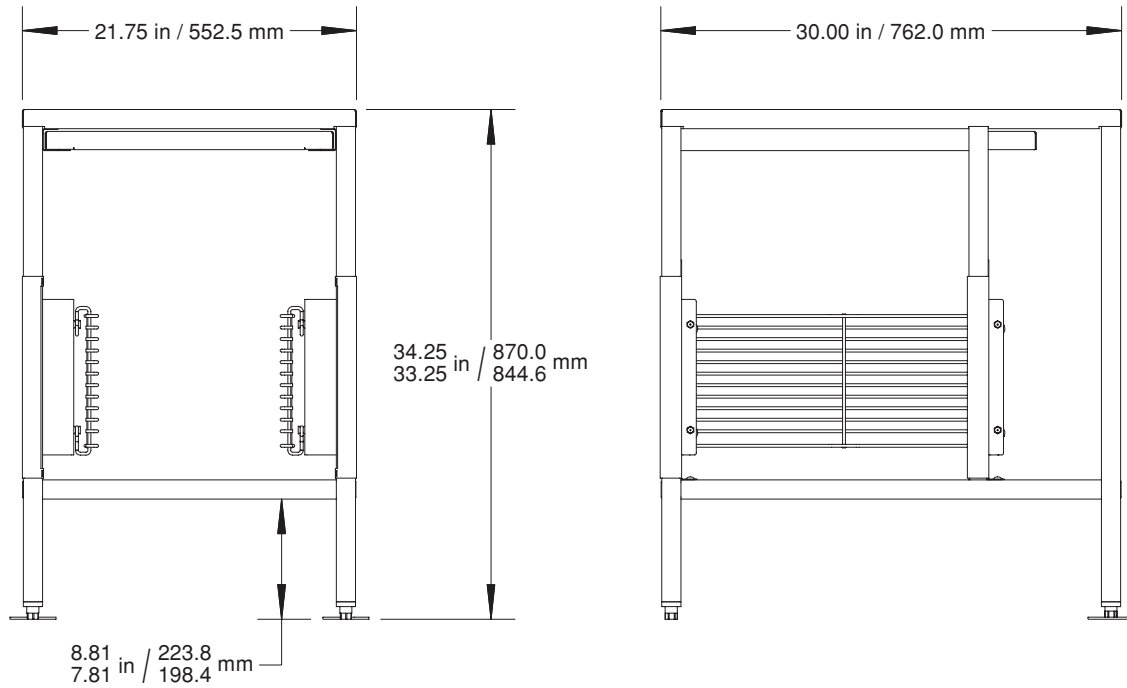

## NOTES:

Cleveland Range reserves right of design improvement or modification, as warranted.  
Many regional, state and local codes exist and it is the responsibility of the owner and installer to comply with the codes.  
Cleveland Range equipment is built to comply with applicable standards for manufacturers.