

MIXER KETTLES, GAS-FIRED VERTICAL AGITATOR TILTING, 2/3 STEAM JACKETED

MODELS: MKGL-40-T MKGL-80-T
 MKGL-60-T

Cleveland Standard Features

- High Efficiency (65%) Forced Air Double Pass Heating System. 140M BTU on 40 gallons, 190M BTU on 60 and 80 gallons
- Automatic Ignition System and 50 psi Steam Jacket Rating
- Insulated Heat Exchanger
- Type 304 Stainless Steel with #4 finish on kettle and supports
- Enclosed, Balanced 10 gauge Stainless Steel hydraulically operated mixer-bridge
- Steam Jacket permanently filled with treated distilled water
- Recessed, front-mounted Pressure/Vacuum Gauge
- Solid-State, precise temperature controls with less than 1° C temperature differences. LED indicator for Heat Cycle and Low Water Indicator, Power On/Off Switch
- Infinitely Variable Ratio Control between Scraper and Agitator. Agitator rotates from 0 to 8 times the speed of the Scraper. Infinitely Variable Scraper Speed Controls from 0 to 45 RPM
- 3-horsepower hydraulic powered Agitator, Scraper and Bridge Lift. Nylon Scraper Blades removable without tools
- 3" diameter Quick Opening Butterfly Valve
- Tilt Mechanism of roller bearings and case hardened self-locking machined worm and segment gear
- Standard for natural gas operation, standard voltage is 120/208-240, 3 phase
- Level adjustable flanged feet, Gallon markings on Scraper Shaft
- Typical approvals include AGA, CSA, CE, NSF and ASME

Options & Accessories

- 316 Stainless Steel Interior Liner. (316G)
- 3" Air Operated Flush Piston Valve. (FPVA3) (for use with a food pump, replaces 3" butterfly valve) (requires air compressor)
- Hot & Cold Water Faucet. (DPK)
- Water Meters (GMC1 or LMC1)
- Two-Piece Lift-Off Covers. (MTP)



Short Form Specifications

Cleveland Gas-Fired Tilting Vertical Mixer Kettle. MKGL-___T ___ gallons, 2/3 steam jacketed, 65% efficient forced air double pass heating system, 50 psi steam jacket rating, automatic ignition, solid-state splash-proof controls, 3" Diameter Butterfly Valve.

- Product Time / Temperature Controls & Indicator. (DTCI)
- Pan Carriers (PCK), Food Strainers. (FS)
- Kettle Accessory Kit (KAK) includes:
 - Clean-up Brush (CB) 36" Kettle Paddle (KP)
 - 36" Kettle Whip (KW) 36" Kettle Brush (KB)
 - Draw-off Brush (DB) 24 oz. Ladle (KL)
- Tri-Basket Strainer Support Systems. (TBS)

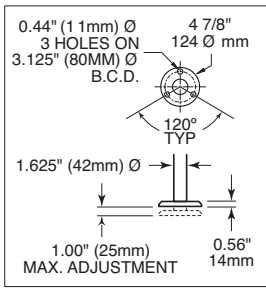

FLANGED FOOT DETAIL

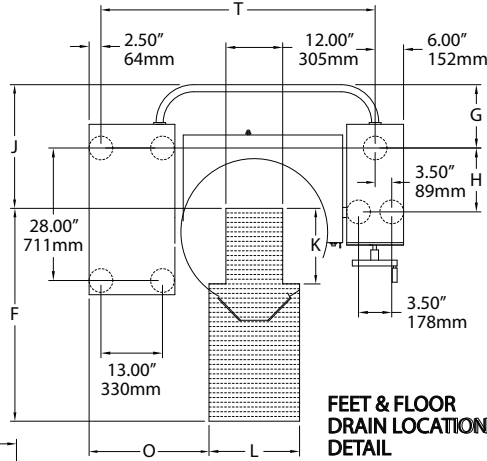

FEET & FLOOR DRAIN LOCATION DETAIL

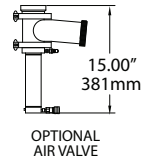
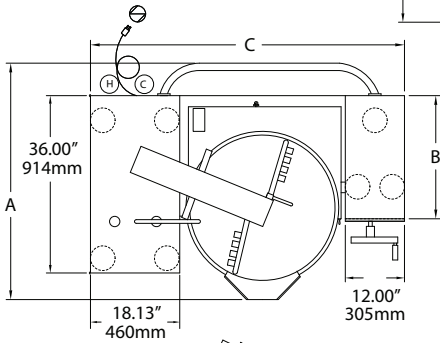

OPTIONAL AIR VALVE

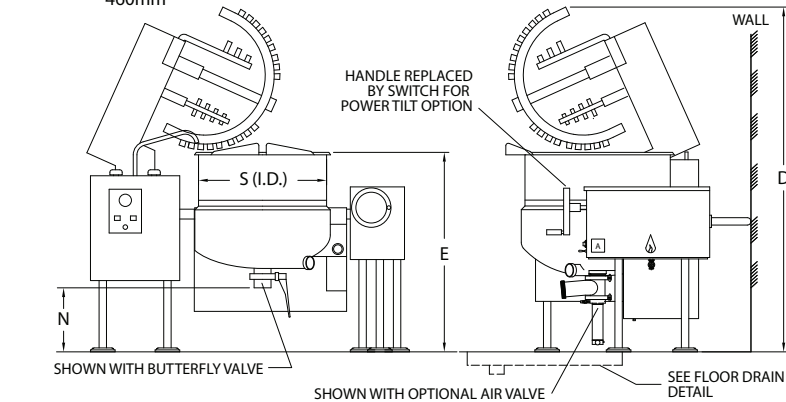

DIMENSIONS:

MODEL NO.	A	B	C	D	E	F	G	H	J	K	L	M	N	O	P	Q	R	S (I.D.)	T
MKGL-40-T	48.00" 1219mm	25.00" 635mm	63.75" 1619mm	70.00" 1778mm	40.50" 1029mm	48.00" 1219mm	13.50" 343mm	13.50" 343mm	24.00" 61mm	23.00" 584mm	25.00" 635mm	14.00" 356mm	13.00" 330mm	21.00" 533mm	34.00" 864mm	69.75" 1772mm	53.75" 1365mm	26.00" 660mm	55.25" 1403mm
MKGL-60-T	50.50" 1283mm	25.50" 648mm	66.63" 1692mm	74.00" 1880mm	43.75" 1111mm	52.00" 1321mm	14.25" 362mm	14.00" 356mm	25.00" 635mm	26.00" 660mm	28.00" 711mm	14.00" 356mm	13.25" 337mm	20.50" 521mm	35.13" 892mm	70.00" 1778mm	55.00" 1397mm	29.50" 749mm	58.13" 1476mm
MKGL-80-T	54.00" 1372mm	26.00" 660mm	70.38" 1788mm	77.00" 1959mm	44.75" 1137mm	54.00" 1372mm	15.75" 400mm	14.50" 368mm	27.00" 686mm	28.00" 711mm	30.00" 762mm	14.00" 356mm	11.75" 298mm	21.63" 549mm	35.75" 908mm	71.50" 1816mm	55.50" 1410mm	33.00" 838mm	61.88" 1572mm

SPECIFICATIONS:

MODEL	ELECTRICAL SUPPLY:				GAS SUPPLY: (PIPING 3/4 NPT)					APPROVALS				CLEARANCE:		SHIPPING WEIGHT
	VOLTS	PHASE	AMPS	FREQ	TYPE	BTU RATING	WATER COLUMN	BTU PER CU. FT.	SUPPLY PRESSURE	AGA	CGA	CE MARK	NSF	RIGHT: 0	LEFT: 0	
MKGL-40-T	208/240	3	15	60	NAT	140,000	3.5	1000	4" TO 14" W.C.	*	*		*	Allow 6.00" (152mm) space. Minimum from rear and sides when located near combustible walls	REAR: 0	MKGL-40-T 850 LBS 386 KGS
	208/240	3	15	60	LP	140,000	3.5	2500	4" TO 14" W.C.	*	*		*			
	480	3	8	60	NAT	140,000	3.5	1000	4" TO 14" W.C.				*			
	480	3	8	60	LP	140,000	3.5	2500	4" TO 14" W.C.				*			
MKGL-60-T	208/240	3	15	60	NAT	190,000	3.5	1000	4" TO 14" W.C.	*	*		*	4.00" (102mm) clearance required if adjoining equipment is over 36" high		MKGL-60-T 925 LBS/LBS 420 KGS
	208/240	3	15	60	LP	190,000	3.5	2500	4" TO 14" W.C.	*	*		*			
MKGL-80-T	480	3	8	60	NAT	190,000	3.5	1000	4" TO 14" W.C.				*			MKGL-80-T 1000 LBS 454 KGS
	480	3	8	60	LP	190,000	3.5	2500	4" TO 14" W.C.				*			
	415	3	9	60	NAT	190,000	3.5	1000	4" TO 14" W.C.				*			

NOTES:

1. MANUFACTURER MUST BE NOTIFIED IF UNIT WILL BE OPERATING ABOVE 2,000 FOOT ALTITUDE.
2. CONSULT FACTORY FOR MANUFACTURED GAS.
3. ALL VERTICAL DIMENSIONS SHOWN ARE MINIMUM. FEET ARE ADJUSTABLE TO 1 INCH MAXIMUM.

NOTES:

Cleveland Range reserves right of design improvement or modification, as warranted. Many regional, state and local codes exist and it is the responsibility of the owner and installer to comply with the codes. Installation of backflow preventers, vacuum breakers and other specific code requirements is the responsibility of the owner and installer. Cleveland Range equipment is built to comply with applicable standards for manufacturers. Included among those approval agencies are U.L., A.G.A., NSF, ASME/N.Bd., CSA, CGA, ETL and others.

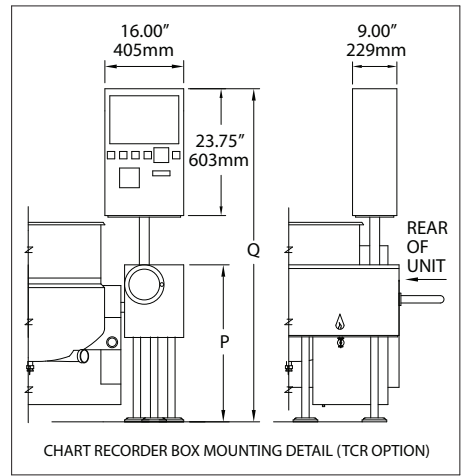
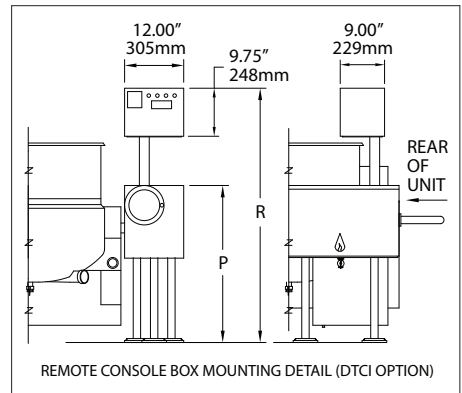
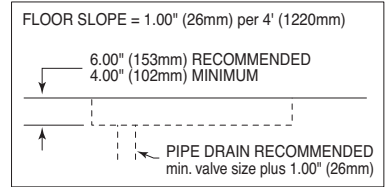

CHART RECORDER BOX MOUNTING DETAIL (TCR OPTION)



REMOTE CONSOLE BOX MOUNTING DETAIL (DTCI OPTION)



RECOMMENDED FLOOR SLOPE