

SWING DRAIN FUNNELS

MODELS: SF1 SF2

Cleveland Standard Features

- For floor model stationary or tilting kettles with a Tangent Draw-Off Valve.
- All Stainless Steel construction
- SF1 For Floor Mounting
- SF2 for Drain Mounting -
 - comes complete with 8' length of 2" ID Hose (HO8.2) to be cut to required length
- Includes Drain Screen

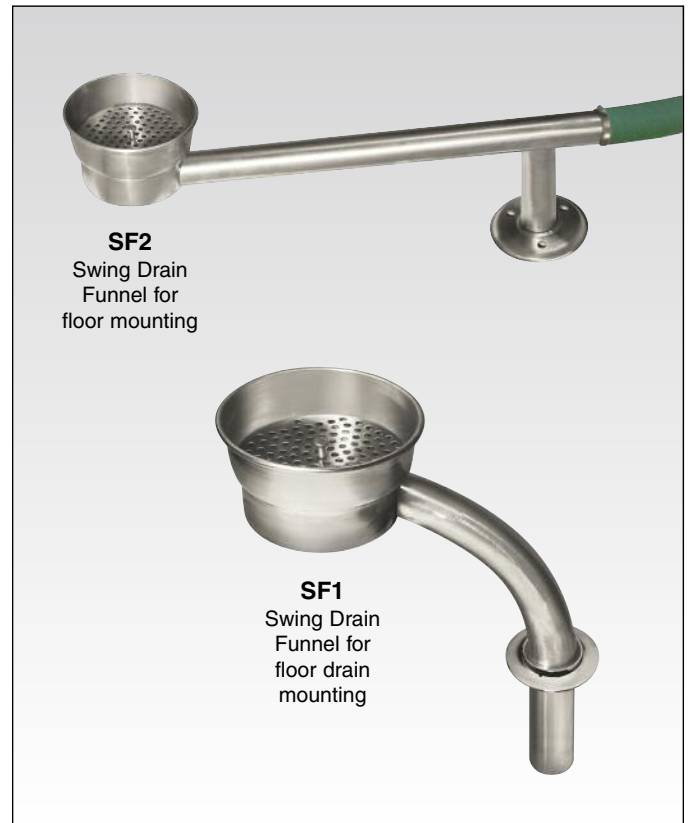

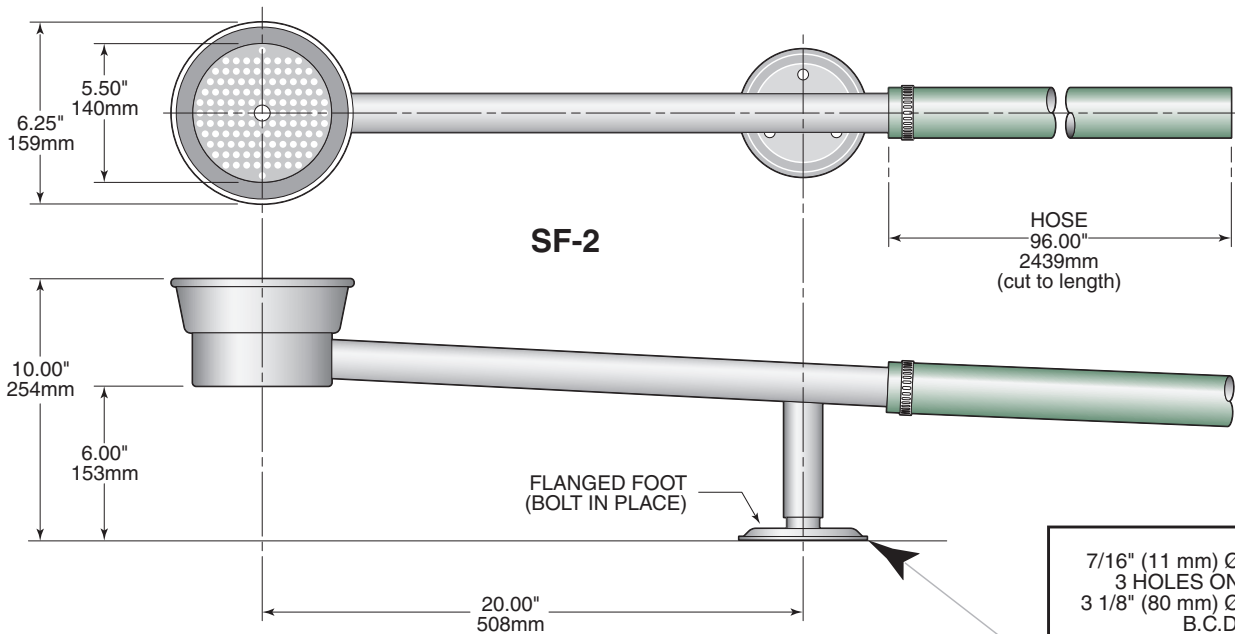
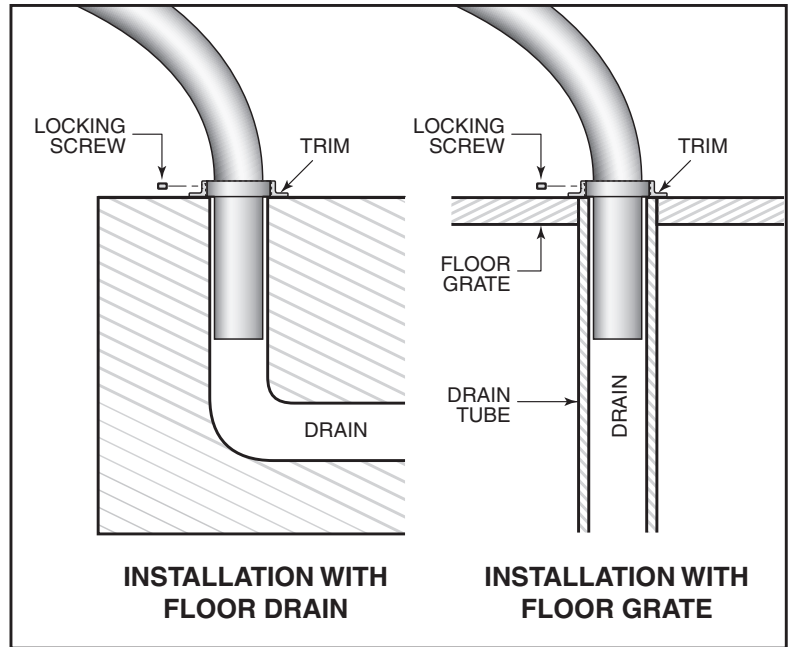
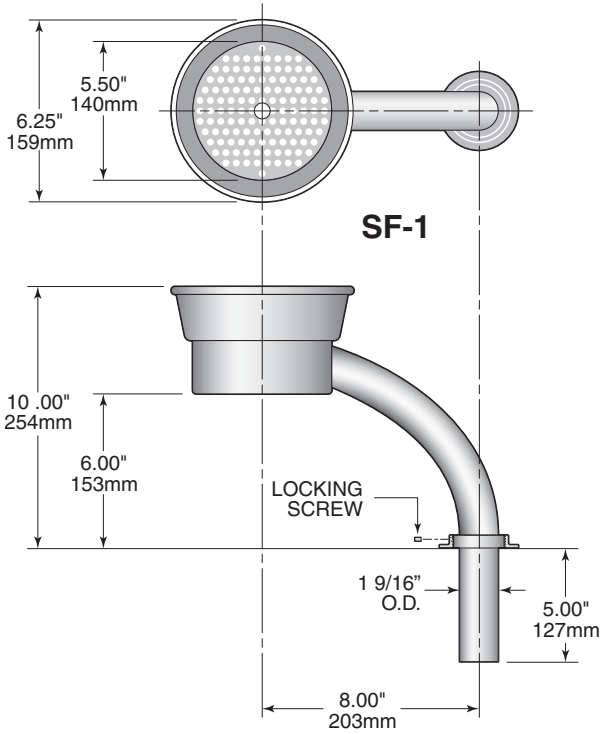

FLANGED FOOT (BOLT IN PLACE)

