

TWIN MIXER KETTLE, ELECTRIC LEG MOUNTED, CONSOLE TYPE 2/3 JACKETED, TILTING

MODELS: TMKEL-40-T TMKEL-80-T
 TMKEL-60-T TMKEL-100-T

Cleveland Standard Features

- Solid State Temperature Control ($\pm 1^{\circ}\text{F}$) for perfect simmering
- Solid State Low Water Safety Control
- Steam Jacket filled with treated water, venting and/or refilling not required
- 50 psi Safety Valve and Steam Jacket Rating
- No Water Gauge required
- Rear mounted Pressure/Vacuum Gauge and Pressure Relief Valve
- Infinitely Variable Scraper Speed Control from 0-40 rpm
- Infinitely Variable Ratio between Scraper And Agitator: Agitator rotates from 0-8 times the speed of the Scraper
- Removable (without tools) Nylon Blades scrape entire Jacketed surface
- 3 Horsepower Hydraulic powered Agitator, Scraper and Bridge Lift
- Safety Device prevents high speed starts
- Mixer stops when Bridge is lifted
- Agitator and Scraper are bayonet mounted for easy removal
- Tilt mechanism of Roller Bearings and case hardened self-Locking worm and segment gear
- Hot and Cold Water Faucets
- 2" diameter Tangent Draw-Off Valve with Drain Strainer
- All Plumbing, Electrical and Hydraulics enclosed in Stainless Steel Consoles
- Enclosed, 10 Gauge Stainless Steel hydraulically operated Mixer Bridge
- Kettle and all Exterior surfaces are Stainless Steel
- Level adjustable feet (flanged for bolting)
- Large Pouring Lip
- Gallon Markings stamped into Scraper Shaft
- Standard 208-240 volts, 60 Hz, 3 phase, 4 wire, high wattage
- Typical approvals include UL., CSA, CE, NSF and ASME

Options & Accessories

- Covers (MPT)
- Product Time/Temperature Controls and Indicators
- Food Strainer (FS-20)
- Flow Diverter (FD)
- Pan Carrier (PCK)
- Swing Funnels (SF-1 or SF-2)
- Alternate Mounting Systems (wall)



Short Form Specifications

Shall be CLEVELAND, Model TMKEL- _____ -T, console/Leg mounted, Electric Mixer KettleS with permanently filled Steam Jackets; 50 psi Kettle Jacket Ratings and Safety Valves, High Wattage standard, Solid State Temperature ($\pm 1^{\circ}\text{F}$) and Low Water Safety Controls. 3 H.P. Hydraulic powered Scraper/Agitator and Bridge Lift. 0-40 rpm Scraper Speed with Variable Scraper to Agitator Ratio from 1-1 to 8-1. Stainless Steel enclosed Mixer Bridge. All Plumbing, Electrical and Hydraulics enclosed in Consoles. Gallon Markings. Safety Device prevent high speed starts. Safety Device prevents high speed starts; Mixer stops when Bridge is lifted. Bayonet Mounted Agitator and Scraper. 2" Tangent Draw-Off Valve. Hot and Cold Water Faucet. Kettle and all exterior surfaces are Stainless Steel.

- Power Tilt (PT)
- Kettle Accessory Kit (KAK) includes:
 - Clean-up Brush (CB) 36" Kettle Paddle (KP)
 - 36" Kettle Whip (KW) 36" Kettle Brush (KB)
 - Draw-off Brush (DB) 24 oz. Ladle (KL)
- Type 316 Stainless Steel Interior for high acid food products (316-20G)
- Water Meter (GMF or LMF) Wall Mount or on Stand (SWM)
- Leg Extensions (ELTMK)
- Voltages (VOS) other than standard

DIMENSIONS ("/mm)

GAL/LIT	A	C	D	E	F	G	H	J	K	L	M	N	O	P	Q	R	S	T	U	V	W	X	Y	Z	A1	A2
40/150	99.00 2511	26.00 660	43.25 1099	52.75 1340	72.00 1829	10.25 260	23.13 587	55.75 1416	11.00 279	39.88 1013	27.38 695	36.00 915	18.38 467	28.00 711	38.00 965	5.63 143	27.00 686	54.38 1381	30.00 762	44.00 1118	30.50 775	18.25 464	76.00 1930	16.00 406	35.75 980	39.00 991
60/225	106.00 2689	29.50 750	43.25 1099	52.75 1340	73.00 1854	10.25 260	23.13 587	57.50 1460	6.63 168	42.13 1070	27.38 695	36.00 915	18.38 467	28.00 711	41.50 1054	6.50 165	9.50 241	58.50 1486	31.00 787	45.00 1143	34.00 864	14.75 375	79.00 2007	18.25 464	37.50 953	40.75 1035
80/300	113.00 2867	33.00 838	45.75 1162	55.25 1403	79.00 2007	12.75 324	26.38 670	59.00 1500	6.63 168	46.38 1178	32.63 778	39.25 997	21.63 549	31.25 794	45.00 1143	7.38 187	31.38 797	63.00 1600	35.00 889	46.00 1168	37.50 953	15.00 381	84.00 2134	19.13 486	42.75 1086	46.00 1168
100/375	117.88 2994	35.50 902	47.75 1213	57.25 1454	82.00 2083	14.75 375	26.38 670	61.00 1550	6.00 152	47.63 1210	32.63 778	39.25 997	21.63 549	31.25 794	47.50 1207	8.00 203	33.00 838	66.00 1676	36.00 914	47.00 1194	40.00 1016	15.00 381	89.00 2261	20.75 527	43.75 1111	47.00 1194

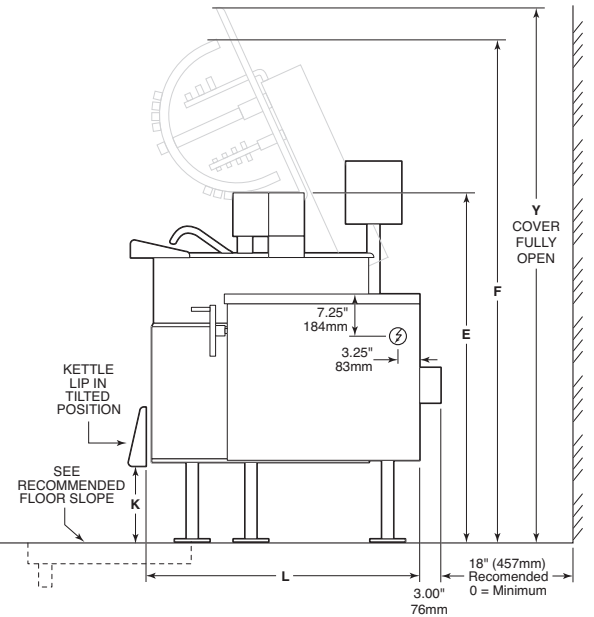
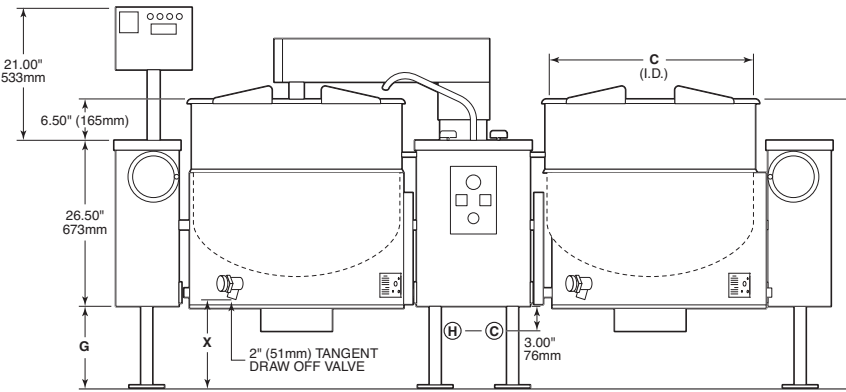
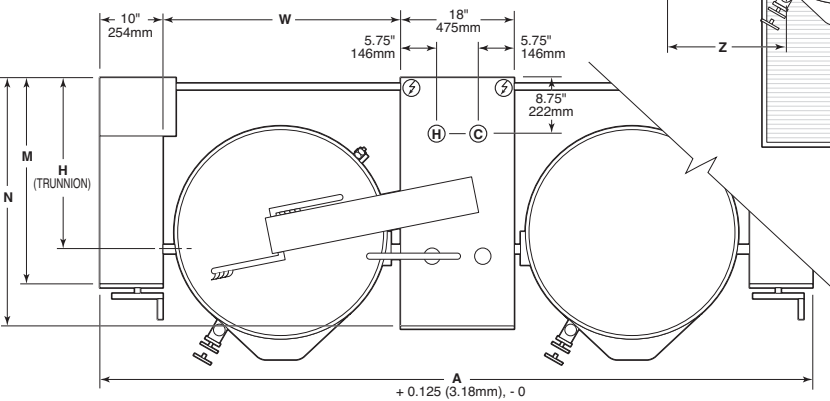
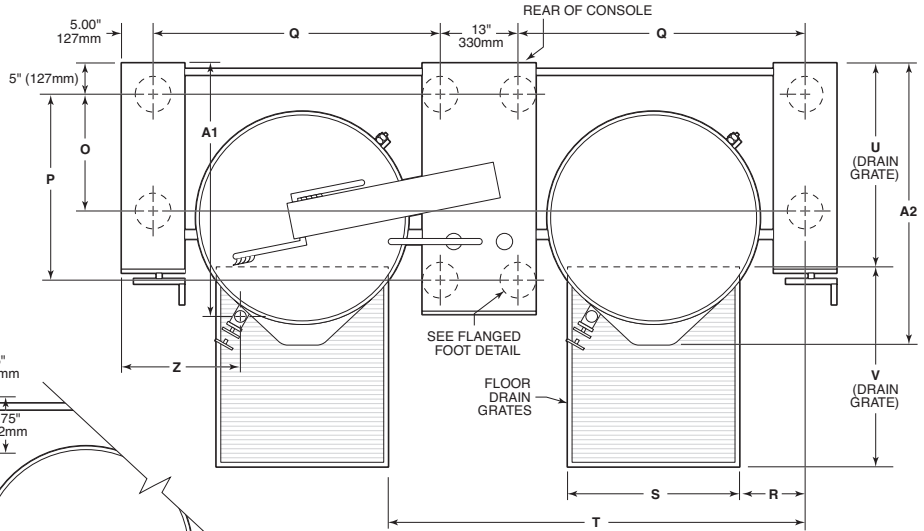
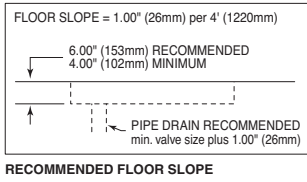
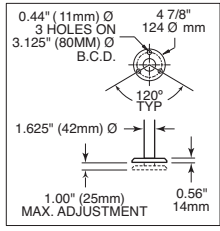

ELECTRICAL - HIGH WATTAGE

Model	Kettle (Left/Right)	Supply Voltage	Phase	Wires	Hz	Total Wattage	Supply Amps	Wire Size
TMKEL-40-T	L	200	3	3	60	22684	81.6	3
	R	200	3	3	60	22684	65.5	4
	L	208	3	3	60	24535	83.8	3
	R	208	3	3	60	24535	68.1	4
TMKEL-60-T	L	220	3	3	60	27448	87.1	2
	R	220	3	3	60	27448	72.0	3
	L	230	3	3	60	30000	90.0	2
	R	230	3	3	60	30000	75.3	3
TMKEL-80-T	L	240	3	3	60	32665	92.8	2
	R	240	3	3	60	32665	78.6	3
	L	380	3	3	60	25153	47.1	6
	R	380	3	3	60	25153	38.2	6

Model	Kettle (Left/Right)	Supply Voltage	Phase	Wires	Hz	Total Wattage	Supply Amps	Wire Size
TMKEL-100-T	L	400	3	3	60	27871	48.8	6
	R	400	3	3	60	27871	40.2	6
	L	415	3	3	60	30000	50.1	6
	R	415	3	3	60	30000	41.7	6
TMKEL-150-T	L	440	3	3	60	27448	44.1	6
	R	440	3	3	60	27448	36.0	8
	L	480	3	3	60	32665	46.9	6
	R	480	3	3	60	32665	39.3	6

Model	Kettle (Left/Right)	Supply Voltage	Phase	Wires	Hz	Total Wattage	Supply Amps	Wire Size
TMKEL-200-T	L	200	3	3	60	27221	94.7	2
	R	200	3	3	60	27221	78.6	3
	L	208	3	3	60	29442	97.4	1
	R	208	3	3	60	29442	81.7	3
TMKEL-300-T	L	220	3	3	60	32938	101.5	1
	R	220	3	3	60	32938	86.4	2
	L	230	3	3	60	36000	105.0	1
	R	230	3	3	60	36000	90.4	2
TMKEL-400-T	L	240	3	3	60	39198	108.5	1
	R	240	3	3	60	39198	94.3	2
	L	380	3	3	60	30184	54.7	6
	R	380	3	3	60	30184	45.9	6

Model	Kettle (Left/Right)	Supply Voltage	Phase	Wires	Hz	Total Wattage	Supply Amps	Wire Size
TMKEL-500-T	L	400	3	3	60	33445	56.8	4
	R	400	3	3	60	33445	48.3	6
	L	415	3	3	60	36000	58.4	4
	R	415	3	3	60	36000	50.1	6
TMKEL-600-T	L	440	3	3	60	32938	51.3	6
	R	440	3	3	60	32938	43.2	6
	L	480	3	3	60	39198	54.8	6
	R	480	3	3	60	39198	47.1	6

WATER

Ⓜ Hot Water 3/4 NPT

Ⓞ Cold Water 3/4 NPT

CLEARANCE

Right - 0, Left - 0

Rear - 18" (457mm)

Recommended 0 - Minimum

NOTES:

Cleveland Range reserves right of design improvement or modification, as warranted.
 Many regional, state and local codes exist and it is the responsibility of the owner and installer to comply with the codes.
 Installation of backflow preventers, vacuum breakers and other specific code requirements is the responsibility of the owner and installer.
 Cleveland Range equipment is built to comply with applicable standards for manufacturers. Included among those approval agencies are U.L., A.G.A., NSF, ASME/N.Bd., CSA, CGA, ETL and others.