

# BACK BAR EQUIPMENT

## Product Specifications

### BBUC50-GD-PT - Undercounter, Display Pass-Thru Cooler

Wear resistant, textured baked enamel finish (black) with aluminum subtop. Heavy-duty galvanized steel interior with reinforced stainless steel floor.

All models are front breathing with refrigeration available on left or right.



#### DIMENSIONAL DATA

|   |   |
|---|---|
| Net Capacity (cu. ft.)                        | 13 (368 cu l)                             |
| Width, Overall (in.)                          | 50 (1270 mm)                              |
| Barrel Capacity (# Barrel Type Kegs)          | -   |
| Straight Wall Capacity (# Straight Wall Kegs) | 2   |
| Depth, Overall (incl. handles) (in.)          | 30 <sup>7</sup> / <sub>8</sub> (784 mm)   |
| Height, Overall (in.)                         | 34 <sup>15</sup> / <sub>16</sub> (887 mm) |
| No. of Door(s)                                | 4   |
| No. of Shelves                                | 4   |

#### REFRIGERANT DATA

|                             |      |
|-----------------------------|------|
| Condensing Unit Size (H.P.) | 1/3  |
| Capacity (BTU/Hr)*          | 1800 |

#### ELECTRICAL DATA

|                           |          |
|---------------------------|----------|
| Cabinet                   | 115/60/1 |
| Feed Wires (incl. ground) | 3        |
| Condensing Unit           | 115/60/1 |
| Total Amps                | 6.0      |
| Cabinet Amps              | 1.4      |

#### SHIPPING DATA

|                       |              |
|-----------------------|--------------|
| Weight (lbs.)         | 365 (166 kg) |
| Height - Crated (in.) | 46 (1168 mm) |
| Width - Crated (in.)  | 58 (1473 mm) |
| Depth - Crated (in.)  | 42 (1067 mm) |

\* Rating @ +25°F evaporator, 90°F ambient  
 Figures in parentheses reflect metric equivalents.

#### OPTIONS AND ACCESSORIES

|   |   |
|---|---|
| • 6" adjustable legs                      | • Condensing unit on right                            |
| • 4" Locking casters                      | • Wine Rack   |
| • Additional shelves                      | • Remote models                                       |
| • Stainless steel shelves with clips      | • Shallow depth                                       |
| • Expansion valve system                  | • Food storage rated stainless steel interior (NSF-7) |
| • Automatic electric condensate vaporizer | • Stainless steel exterior                            |



Toll-Free: 800-523-7138  
 Phone: 215-244-1400  
 Fax: 215-244-9579

539 Dunksferry Road  
 Bensalem, PA 19020  
[www.continentalrefrigerator.com](http://www.continentalrefrigerator.com)

Project Name:

Model Specified:

Location:

Item No:  Quantity:

APPROVAL:

## Standard Design Features

### REFRIGERATION SYSTEM

Environmentally-safe R-134a refrigerant

### CABINET ARCHITECTURE

High density, non-CFC polyurethane foamed-in-place insulation

Wear resistant, textured baked enamel finish (black)

Aluminum sub top

Heavy-duty galvanized steel interior with reinforced stainless steel floor

Heavy-duty, adjustable, epoxy-coated steel shelves

Stainless steel reinforced threshold sills for ease of loading

Cylinder keyed security locks

Magnetic snap-in door gaskets

### MODEL FEATURES

Front breathing

Easily accessible and serviceable slide-out condensing unit

Automatic, energy-saving, non-electric condensate evaporator

Front, rear and side venting louvers allow greater condenser air flow for tight fit installations

Incandescent interior lighting

Extra large fin evaporator coil provides uniform air flow distribution to maintain constant product temperature and quick recovery

### ELECTRICAL

Completely pre-wired at factory for connection to 115/60/1 phase, 15 amp dedicated outlet

10 ft. cord and plug set included, 90° plug



Equipped with one NEMA-5-15P Plug

# BACK BAR EQUIPMENT

## BBUC50-GD-PT - Undercounter Display Pass-Thru Model Blueprint

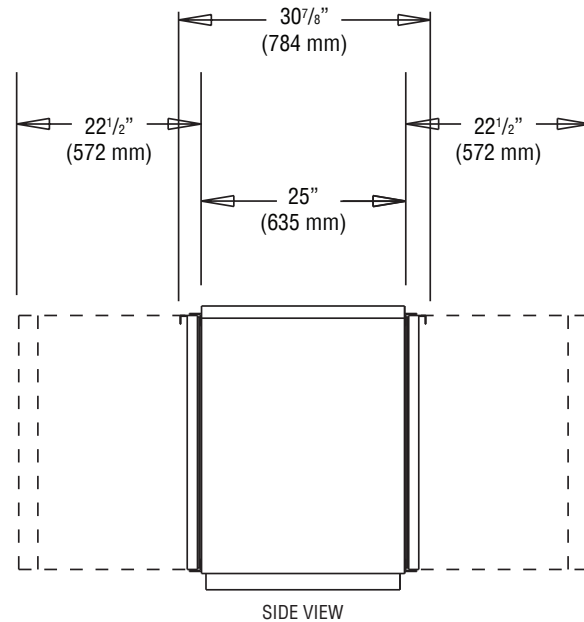
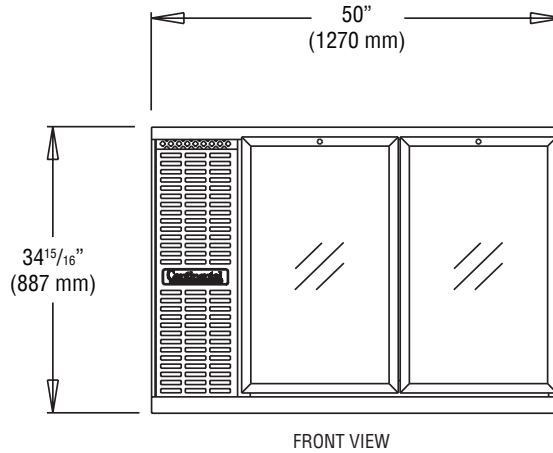

This Continental Refrigerator product is warranted to be free from all manufacturing defects, material or workmanship, for a period of one (1) year from date of original installation, or fifteen (15) months from date of shipment, whichever occurs first. All motor-compressor assemblies are warranted to be free from defects, material and workmanship, for a period of five (5) years from date of installation.

Due to our continued efforts in developing innovative products, specifications subject to change without notice.



MADE IN THE U.S.A.

© Copyright 2011. Continental Refrigerator.  
A Division of National Refrigeration & Air Conditioning Products, Inc.

**Continental**  
Refrigerator

Toll-Free: 800-523-7138  
Phone: 215-244-1400  
Fax: 215-244-9579

539 Dunksferry Road  
Bensalem, PA 19020  
[www.continentalrefrigerator.com](http://www.continentalrefrigerator.com)

BBUC50-GD-PT (5/10/11)