

# BACK BAR COOLERS

## Product Specifications

### BBUC79S-GD - Undercounter 79" Shallow Depth Display Cooler with Hinged Glass Doors

Cabinet construction consist of wear resistant, textured baked enamel finish (black) with aluminum subtop, heavy-duty galvanized interior and reinforced stainless steel floor. Front breathing with refrigeration available on left or right.



#### DIMENSIONAL DATA

Net Capacity (cu. ft.)	22 (623 cu l)
Width, Overall (in.)	79 (2007 mm)
Barrel Capacity (# Barrel Type Kegs)	3
Straight Wall Capacity (# Straight Wall Kegs)	3
Depth, Overall (incl. handles & bumpers) (in.)	24 <sup>5</sup> / <sub>8</sub> (625 mm)
Height, Overall (in.)	34 <sup>15</sup> / <sub>16</sub> (887 mm)
No. of Door(s)	3
No. of Shelves	6

#### REFRIGERANT DATA

Condensing Unit Size (H.P.)	1/3
Capacity (BTU/Hr)*	2500

#### ELECTRICAL DATA

Cabinet	115/60/1
Feed Wires (incl. ground)	3
Condensing Unit	115/60/1
Total Amps	7.7
Cabinet Amps	3.1
Power Supply Cord	Yes

#### SHIPPING DATA

Weight (lbs.)	465 (211 kg)
Height - Crated (in.)	46 (1168 mm)
Width - Crated (in.)	88 (2235 mm)
Depth - Crated (in.)	42 (1067 mm)

\* Rating @ +25°F evaporator, 90°F ambient  
 Figures in parentheses reflect metric equivalents rounded to the nearest whole millimeter.

#### OPTIONS AND ACCESSORIES

- |   |   |
|---|---|
| • 6" Adjustable legs                        | • Stainless steel subtop                              |
| • Locking casters                           | • Condensing unit on right                            |
| • Epoxy-coated shelves with clips           | • Wine Rack   |
| • Stainless steel shelves with clips        | • Remote models                                       |
| • Expansion valve system                    | • Food storage rated stainless steel interior (NSF-7) |
| • Automatic, electric condensate evaporator |   |

**Continental**  
 Refrigerator

Toll-Free: 800-523-7138  
 Phone: 215-244-1400  
 Fax: 215-244-9579

539 Dunksferry Road  
 Bensalem, PA 19020  
[www.continentalrefrigerator.com](http://www.continentalrefrigerator.com)

Project Name:

Model Specified:

Location:

Item No:  Quantity:

APPROVAL:

## Standard Design Features

### REFRIGERATION SYSTEM

Environmentally-safe R-134a refrigerant

Automatic, energy-saving, non-electric condensate evaporator

Full length, extra large coil provides uniform air flow distribution to maintain constant product temperature and quick recovery

### CABINET ARCHITECTURE

High density, non-CFC polyurethane foamed-in-place insulation

Wear resistant, textured baked enamel finish (black)

Aluminum subtop

Heavy-duty galvanized steel interior with reinforced stainless steel floor

Stainless steel reinforced threshold sills for ease of loading

Heavy-duty epoxy-coated steel shelves

Hinged glass doors

Cylinder-keyed security lock in each door

Magnetic snap-in door gaskets

### MODEL FEATURES

Front breathing

Easily accessible and serviceable slide-out condensing unit

Front, rear and side venting louvers allow greater condenser air flow for tight fit installations

Flourescent interior lighting

### ELECTRICAL

10 ft. cord and plug set included, 90° plug



Equipped with one NEMA-5-15P Plug

# BACK BAR COOLERS

## BBUC79S-GD - Undercounter 79" Shallow Depth Display Cooler with Hinged Glass Doors

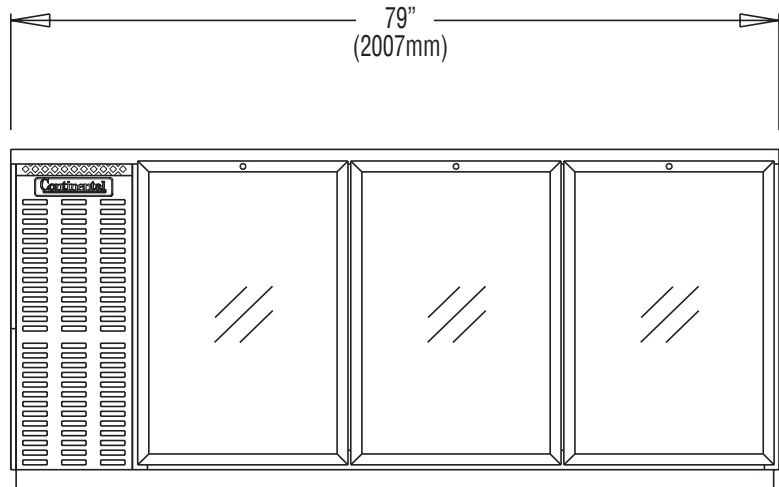

FRONT VIEW

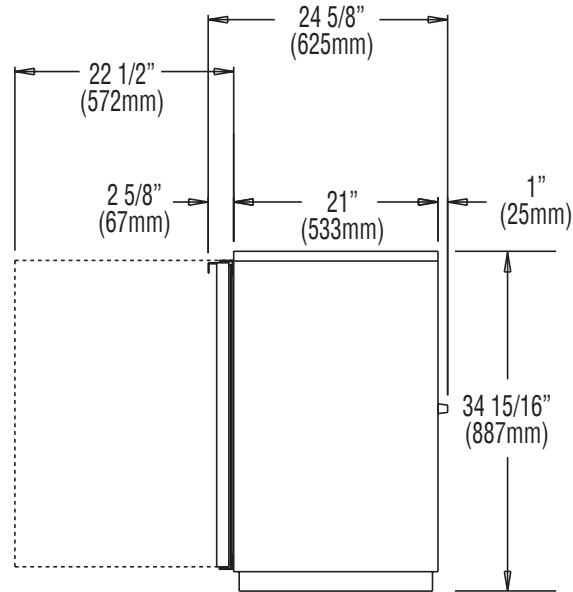

SIDE VIEW



This Continental Refrigerator product is warranted to be free from all manufacturing defects, material or workmanship, for a period of one (1) year from date of original installation, or fifteen (15) months from date of shipment, whichever occurs first. All motor-compressor assemblies are warranted to be free from defects, material and workmanship, for a period of five (5) years from date of installation.

Due to our continued efforts in developing innovative products, specifications subject to change without notice.



MADE IN THE U.S.A.

© Copyright 2012, Continental Refrigerator.  
A Division of National Refrigeration & Air Conditioning Products, Inc.

# Continental

Refrigerator

Toll-Free: 800-523-7138  
Phone: 215-244-1400  
Fax: 215-244-9579

539 Dunksferry Road  
Bensalem, PA 19020  
[www.continentalrefrigerator.com](http://www.continentalrefrigerator.com)

BBUC79S-GD (11/29/12)