

# BACK BAR EQUIPMENT

## Product Specifications

### BBUC90-SS-PT Undercounter Pass-Thru Cooler with Stainless Steel Exterior

Cabinet has an aluminum subtop and heavy-duty galvanized steel interior with reinforced stainless steel floor.

All models are front breathing with refrigeration available on left or right.



#### DIMENSIONAL DATA

|   |   |
|---|---|
| Net Capacity (cu. ft.)                        | 35 (991 cu l)                             |
| Width, Overall (in.)                          | 90 (2286 mm)                              |
| Barrel Capacity (# Barrel Type Kegs)          | 4   |
| Straight Wall Capacity (# Straight Wall Kegs) | 4   |
| Depth, Overall (incl. handles) (in.)          | 30 <sup>7</sup> / <sub>8</sub> (784 mm)   |
| Height, Overall (in.)                         | 34 <sup>15</sup> / <sub>16</sub> (887 mm) |
| No. of Door(s)                                | 6   |
| No. of Shelves                                | 6   |

#### REFRIGERANT DATA

|                             |      |
|-----------------------------|------|
| Condensing Unit Size (H.P.) | 1/2  |
| Capacity (BTU/Hr)*          | 2500 |

#### ELECTRICAL DATA

|                           |          |
|---------------------------|----------|
| Cabinet                   | 115/60/1 |
| Feed Wires (incl. ground) | 3        |
| Condensing Unit           | 115/60/1 |
| Total Amps                | 13       |
| Cabinet Amps              | 2.4      |

#### SHIPPING DATA

|                       |               |
|-----------------------|---------------|
| Weight (lbs.)         | 505 (229 kg)  |
| Height - Crated (in.) | 46 (1168 mm)  |
| Width - Crated (in.)  | 109 (2769 mm) |
| Depth - Crated (in.)  | 42 (1067 mm)  |

\* Rating @ +25°F evaporator, 90°F ambient  
Figures in parentheses reflect metric equivalents.

#### OPTIONS AND ACCESSORIES

- |                                      |   |
|--------------------------------------|---|
| • 6" adjustable legs                 | • Condensing unit on right                            |
| • Locking casters                    | • Wine Rack   |
| • Epoxy-coated shelves with clips    | • Remote models                                       |
| • Stainless steel shelves with clips | • Shallow depth                                       |
| • Expansion valve system             | • Food storage rated stainless steel interior (NSF-7) |
| • Electric condensate                |   |

**Continental**  
Refrigerator

Toll-Free: 800-523-7138  
Phone: 215-244-1400  
Fax: 215-244-9579

539 Dunksferry Road  
Bensalem, PA 19020  
www.continentalrefrigerator.com

Project Name:

Model Specified:

Location:

Item No:  Quantity:

APPROVAL:

## Standard Design Features

### REFRIGERATION SYSTEM

Environmentally-safe R-134a refrigerant

### CABINET ARCHITECTURE

High density, non-CFC polyurethane foam insulation

Stainless steel exterior

Aluminum top

Heavy-duty galvanized steel interior with reinforced stainless steel floor

Heavy-duty epoxy-coated steel shelves

Stainless steel reinforced threshold sills for ease of loading

Cylinder keyed security locks

Magnetic snap-in door gaskets

### MODEL FEATURES

Front breathing

Easily accessible and serviceable slide-out condensing unit

Automatic, energy-saving, non-electric condensate evaporator

Front, rear and side venting louvers allow greater condenser air flow for tight fit installations

Incandescent interior lighting

Extra large fin evaporator coil provides uniform air flow distribution to maintain constant product temperature and quick recovery

### ELECTRICAL

Completely pre-wired at factory for connection to 115/60/1 phase, 15 amp dedicated outlet

10 ft. cord and plug set included, 90° plug



Equipped with one NEMA-5-15P Plug

# BACK BAR EQUIPMENT

## BBUC90-SS-PT - Undercounter Pass-Thru Model Blueprint with Stainless Steel Exterior

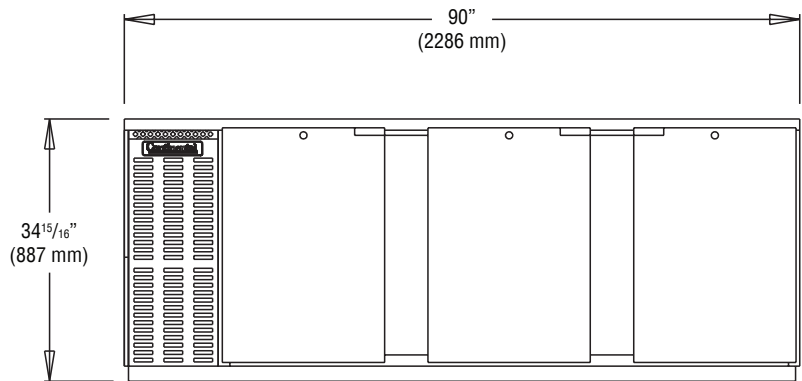

FRONT VIEW

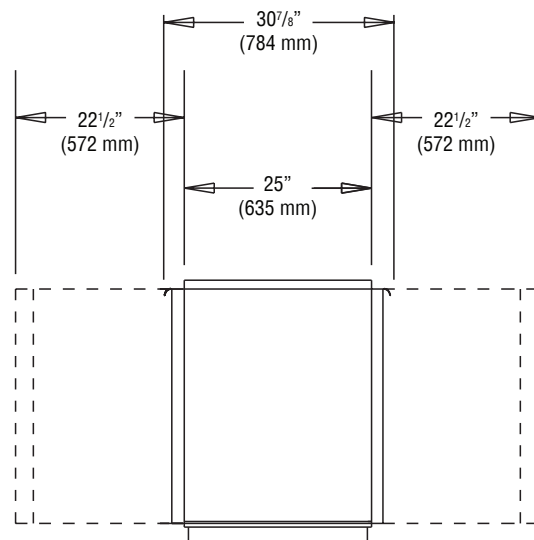

SIDE VIEW



This Continental Refrigerator product is warranted to be free from all manufacturing defects, material or workmanship, for a period of one (1) year from date of original installation, or fifteen (15) months from date of shipment, whichever occurs first. All motor-compressor assemblies are warranted to be free from defects, material and workmanship, for a period of five (5) years from date of installation.

Due to our continued efforts in developing innovative products, specifications subject to change without notice.



MADE IN THE U.S.A.

© Copyright 2011. Continental Refrigerator.  
A Division of National Refrigeration & Air Conditioning Products, Inc.

# Continental

Refrigerator

Toll-Free: 800-523-7138  
Phone: 215-244-1400  
Fax: 215-244-9579

539 Dunksferry Road  
Bensalem, PA 19020  
[www.continentalrefrigerator.com](http://www.continentalrefrigerator.com)

BBUC90-SS-PT (5/10/11)