

# BASE MODEL FREEZER (0°F)

**Model: CFA60-D**

## 60" Worktop Freezer with Drawers

(Door on Smaller Width Section)

Heavy gauge #300 Series stainless steel top, stainless steel front and end panels, galvanized steel rear and grill and aluminum interior.

**Designed to maintain NSF-7 temperatures in 100°F ambient.**



### Options and Accessories

(upcharge and lead times may apply)

Door in lieu of drawers (larger section)	Stainless steel back and interior
Drawer section above the condensing unit*	Condensing unit left or right
Overshelves (single or double)	Remote models
Automatic, electric condensate evaporator	Door/drawer locks
Exterior dial or digital thermometer	Adjustable legs
Additional epoxy-coated steel shelves	Front breathing
Stainless steel shelves	

\*Drawer section above condensing unit holds (1) 12 x 20 x 6 pan

Project Name:

Model Specified:

Location:

Item No:

Quantity:

AIA #:

SIS #:

### Standard Model Features

#### REFRIGERATION SYSTEM

Performance-rated refrigeration system

Environmentally-safe R-404A refrigerant

Unique forced air design utilizes fans (approx. every 12") across the entire back of unit for even distribution of cold

Automatic, energy saving, non-electric condensate evaporator

Non-corrosive, plasticized fin evaporator coil

Easily serviceable, slide-out condensing unit

#### CABINET ARCHITECTURE

2" non-CFC polyurethane foam insulation

Spring loaded, self closing door (smaller section and over condensing unit)

Magnetic snap-in door/drawer gaskets

Stainless steel roll-out drawers (larger section)

5" casters

Completely enclosed, vented and removable rear and side grills

Refrigerated door section above the condensing unit

#### MODEL FEATURES

Automatic electric defrost

Interior hanging thermometer

Field rehingeable door (over condensing unit)

**NOTE:** CFA60-D drawer models come standard with a door over the condensing unit, a solid door (left section) and two tier drawers (center section). A drawer over the condensing unit is an option. The option of having the door/drawers located in the opposite sections **MUST** be indicated at the time of ordering.

**Continental**  
Refrigerator

Toll-Free: 800-523-7138  
Phone: 215-244-1400  
Fax: 215-244-9579

539 Dunksferry Road  
Bensalem, PA 19020  
[www.continentalrefrigerator.com](http://www.continentalrefrigerator.com)

APPROVAL:

## Model Specifications

### DIMENSIONAL DATA

Net Capacity (cu. ft.)	19 (538 cu l)
Width, Overall (in.)	60 (1524 mm)
Depth, Overall (in.) (incl. handles & bumpers)	36 1/16 (916 mm)
Height, Overall (in.) (incl. 5" casters)	35 (889 mm)
Shelf Area (sq. ft.)	5.6 (.5 sq m)
No. of Shelves	2
No. of Drawers	2
No. of Full Doors	1
No. of Half Doors	1
Interior Depth (in.) (above condenser)	30 (762 mm)
Interior Height (in.) (smaller section)	26 (660 mm)
Interior Height (in.) (above condenser)	12 1/2 (318 mm)
Interior Width (in.) (smaller section)	17 (422 mm)
Interior Width (in.) (above condenser)	17 (422 mm)

### REFRIGERANT DATA

Condensing Unit Size (H.P.)	1/2
Capacity (BTU/Hr)*	2180

### ELECTRICAL DATA

Voltage (int'l)	115/60/1 (220/50/1)
Fans	3
Total Amps (int'l)	10.0 (4.6)
10 ft. Cord/Plug [attached] (int'l)	Yes (No)

### SHIPPING DATA

Weight (lbs.)	410 (186 kg)
Height - Crated (in.)	43 3/4 (1111 mm)
Width - Crated (in.)	62 (1575 mm)
Depth - Crated (in.)	47 (1194 mm)

### DRAWER PAN CONFIGURATIONS

**Two Tier:** (2) 12 x 20 x 6 pans per drawer

**Three Tier:** (1) 12 x 20 x 4 pan per drawer (top)  
and (2) 12 x 20 x 4 pans per drawer (center & bottom)

\* Rating @ -15°F evaporator, 90°F ambient

Figures in parentheses reflect metric equivalents rounded to the nearest whole unit.

## Model Plan Views

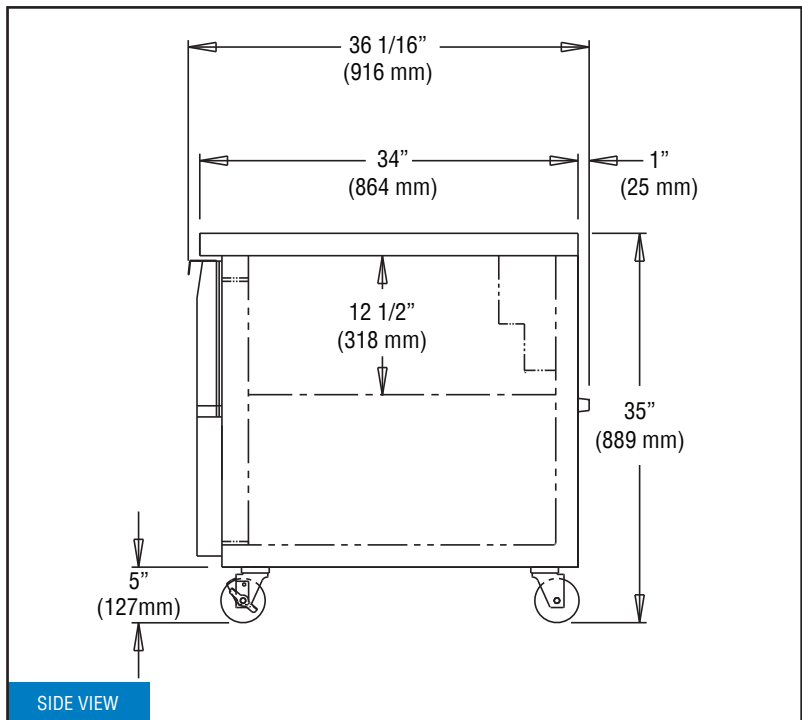
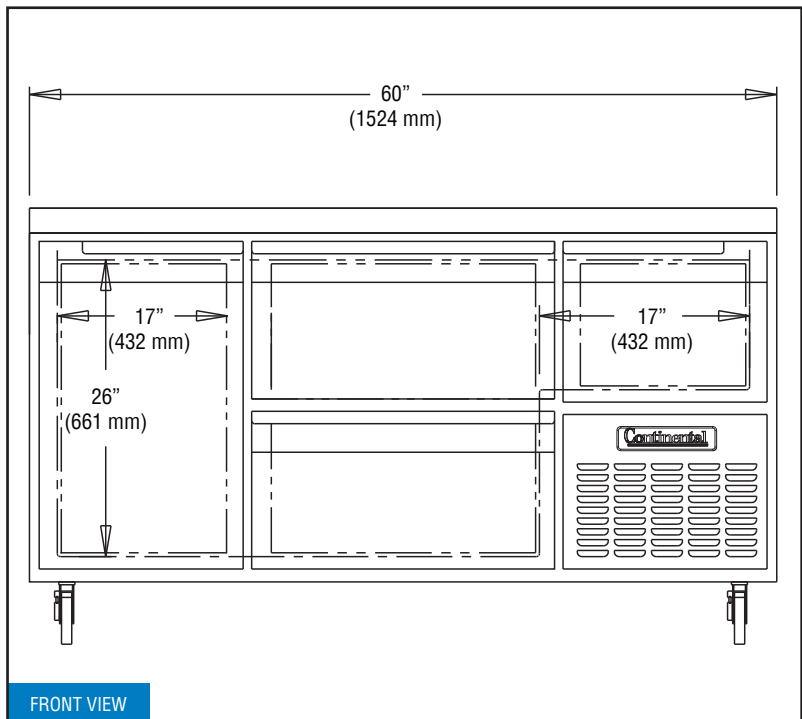

**Continental**  
Refrigerator

Toll-Free: 800-523-7138  
Phone: 215-244-1400  
Fax: 215-244-9579

539 Dunkserry Road  
Bensalem, PA 19020  
[www.continentalrefrigerator.com](http://www.continentalrefrigerator.com)

Due to our continued efforts in developing innovative products, specifications subject to change without notice.



© Copyright 2014. Continental Refrigerator.  
A Division of National Refrigeration & Air Conditioning Products, Inc.



Equipped with one NEMA-5-15P Plug  
(varies by country)

CFA60-D (7/29/14)