

BACK BAR EQUIPMENT

Model: CGC50

50" Glass & Plate Chiller (0°F)

Textured baked enamel finish (black) exterior with all stainless steel countertop and slide lid, heavy-duty galvanized interior.

Designed to maintain NSF-7 temperatures in 100°F ambient.



Options and Accessories

(upcharge and lead times may apply)

Stainless steel exterior (-SS models)	Expansion valve system
Stainless steel interior	Casters
Additional epoxy-coated, steel wire shelves	Adjustable legs
Lid locks	Remote models
Automatic, electric condensate evaporator	

Consult factory for other model configurations, options and accessories.

Project Name:

Model Specified:

Location:

Item No:

Quantity:

AIA #:

SIS #:

Standard Model Features

REFRIGERATION SYSTEM

Environmentally-safe R-404A refrigerant

Performance-rated refrigeration system

Full length, extra large coil for quick top row product chilling

Easily accessible and serviceable slide-out condensing unit

CABINET ARCHITECTURE

High density, non-CFC polyurethane foamed-in-place insulation

Heavy-duty sliding shelves

Front, rear and side venting louvered panels

MODEL FEATURES

Automatic time defrosting period is timer initiated and temperature terminated with automatic, energy-saving, non-electric condensate evaporator

Cabinet will maintain 0°F and below for fast frosting of wet or dry glasses

Continental
Refrigerator

Toll-Free: 800-523-7138
Phone: 215-244-1400
Fax: 215-244-9579

539 Dunksferry Road
Bensalem, PA 19020
www.continentalrefrigerator.com

APPROVAL:

Model Specifications

DIMENSIONAL DATA

Net Capacity (cu. ft.)	15.1 (428 cu l)
5" Mug Capacity (# mugs)	265
Stein Capacity (# 10 oz. steins)	250
Width, Overall (in.)	50 (1270 mm)
Depth, Overall (in.) (incl. bumpers)	28 1/2 (724 mm)
Height, Overall (in.)	33 1/2 (851 mm)
No. of Slide Lids	2
No. of Shelves	4

REFRIGERANT DATA

Condensing Unit Size (H.P.)	1/3
Capacity (BTU/Hr)*	1350

ELECTRICAL DATA

Voltage (int'l)	115/60/1 (220/50/1)
Feed Wires (incl. ground)	3
Total Amps (int'l)	6.1 (3.7)
10 ft. Cord/Plug [attached] (int'l)	Yes (No)

SHIPPING DATA

Weight - (lbs.)	285 (129 kg)
Height - Crated (in.)	39 (991 mm)
Width - Crated (in.)	57 3/4 (1467 mm)
Depth - Crated (in.)	30 1/4 (768 mm)

* Rating @ -15°F evaporator, 90°F ambient

Figures in parentheses reflect metric equivalents rounded to the nearest whole unit.



Equipped with one NEMA-5-15P Plug
(varies by country)

Continental
Refrigerator

Toll-Free: 800-523-7138
Phone: 215-244-1400
Fax: 215-244-9579

539 Dunkserry Road
Bensalem, PA 19020
www.continentalrefrigerator.com

Due to our continued efforts in developing innovative products, specifications subject to change without notice.



MADE IN THE U.S.A.

© Copyright 2015. Continental Refrigerator.
A Division of National Refrigeration & Air Conditioning Products, Inc.

Model Plan Views

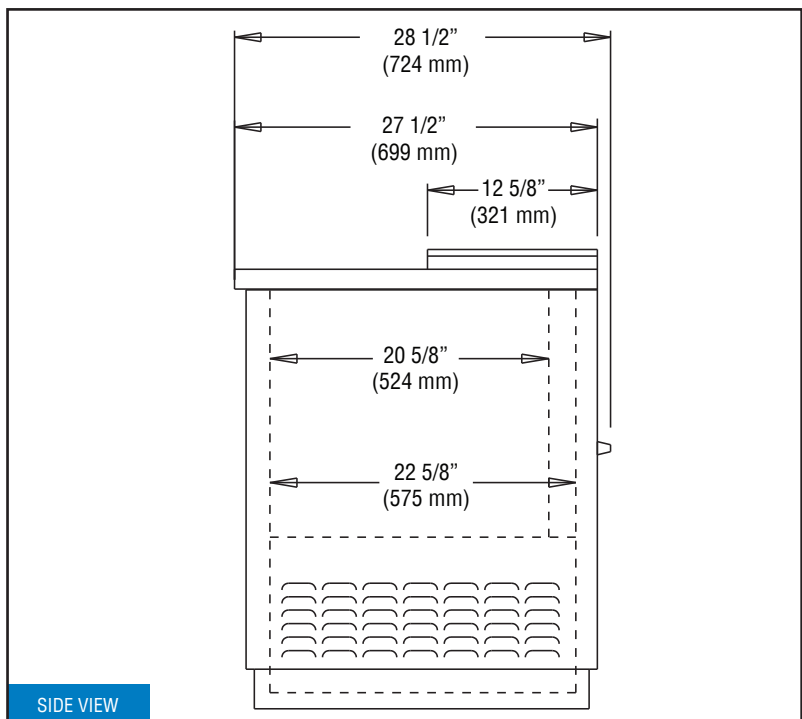
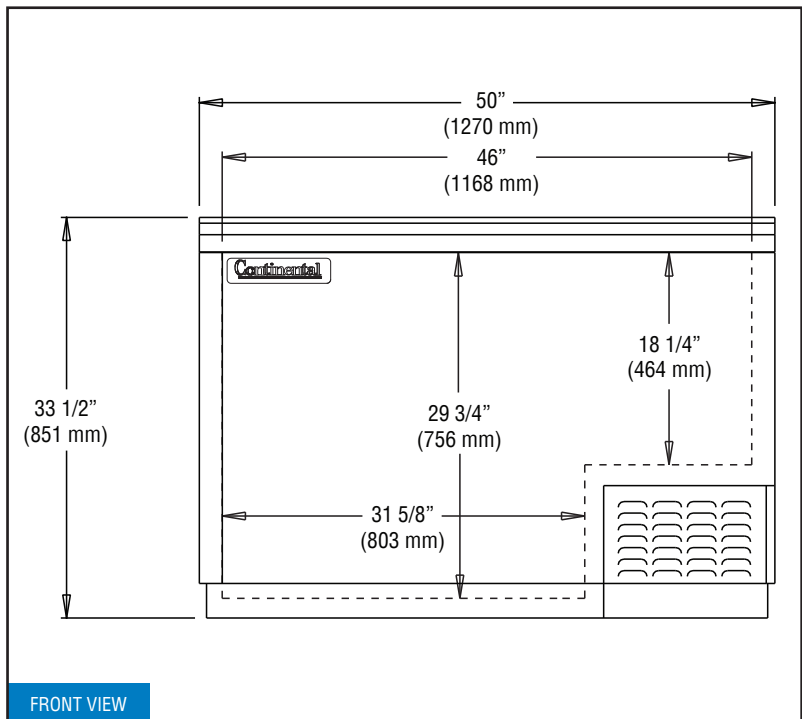

IMPORTANT NOTE: A minimum clearance of 3" is required on each side, front and rear of cabinet for optimum performance.