

# BASE MODEL FREEZER (0°F)

**Model: CUFA93**

## 93" Undercounter Freezer with Solid Doors

Stainless steel front and end panels, aluminum subtop and interior.

**Designed to maintain NSF-7 temperatures in 100°F ambient.**



### Options and Accessories

(upcharge and lead times may apply)

Drawers in lieu of doors (full door sections only)	Condensing unit left or right
Additional epoxy-coated steel shelves	Stainless steel pan slides
Stainless steel shelves	Remote models
Automatic, electric condensate evaporator	Door locks
Stainless steel back and interior	Adjustable legs
Exterior dial or digital thermometer	

Project Name:

Model Specified:

Location:

Item No:

Quantity:

AIA #:

SIS #:

### Standard Model Features

#### REFRIGERATION SYSTEM

- Performance-rated **front breathing** refrigeration system
- Environmentally-safe R-404A refrigerant
- Unique forced air design utilizes fans (approx. every 12") across the entire back of unit for even distribution of cold
- Automatic, energy saving, non-electric condensate evaporator
- Non-corrosive, plasticized fin evaporator coil
- Easily serviceable, slide-out condensing unit

#### CABINET ARCHITECTURE

- 2" non-CFC polyurethane foam insulation
- Spring loaded, self closing doors
- Magnetic snap-in door gaskets
- Heavy-duty, epoxy-coated steel shelves
- 3 5/8" casters
- Completely enclosed, vented and removable rear grill
- Refrigerated door section above the condensing unit

#### MODEL FEATURES

- Automatic electric defrost
- Interior hanging thermometer
- Field rehingeable doors

**NOTE:** CUFA models come standard with a door over the condensing unit. A drawer over the condensing unit is not available on Undercounter Freezer models.

Front breathers are a unique, field assembled, bottom mounted ventilation system designed to allow cabinets to be flush against a wall or built into a counter to conserve space.

**Continental**  
Refrigerator

Toll-Free: 800-523-7138  
Phone: 215-244-1400  
Fax: 215-244-9579

539 Dunksferry Road  
Bensalem, PA 19020  
[www.continentalrefrigerator.com](http://www.continentalrefrigerator.com)

APPROVAL:

## Model Specifications

### DIMENSIONAL DATA

Net Capacity (cu. ft.)	32 (906 cu l)
Width, Overall (in.)	93 3/16 (2367 mm)
Depth, Overall (in.) (incl. handles & bumpers)	36 1/16 (916 mm)
Height, Overall (in.) (incl. 3 5/8" casters)	31 13/16 (808 mm)
Shelf Area (sq. ft.)	14.2 (1.3 sq m)
No. of Shelves	6
No. of Full Doors	3
No. of Half Doors	1
Interior Depth (in.)	30 (762 mm)
Interior Height (in.)	26 (660 mm)
Interior Height (in.) (above condenser)	12 1/2 (318 mm)
Interior Width (in.)	89 (2261 mm)

### REFRIGERANT DATA

Condensing Unit Size (H.P.)	3/4
Capacity (BTU/Hr)*	2750

### ELECTRICAL DATA

Voltage (int'l)	115/60/1 (220/50/1)
Fans	5
Total Amps (int'l)	16.5 (11.0)
10 ft. Cord/Plug [attached] (int'l)	Yes (No)

### SHIPPING DATA

Weight (lbs.)	600 (272 kg)
Height - Crated (in.)	43 3/4 (1111 mm)
Width - Crated (in.)	95 (2413 mm)
Depth - Crated (in.)	47 (1194 mm)

\* Rating @ -15°F evaporator, 90°F ambient

Figures in parentheses reflect metric equivalents rounded to the nearest whole unit.



Equipped with one NEMA-5-15P Plug  
(varies by country)

## Model Plan Views

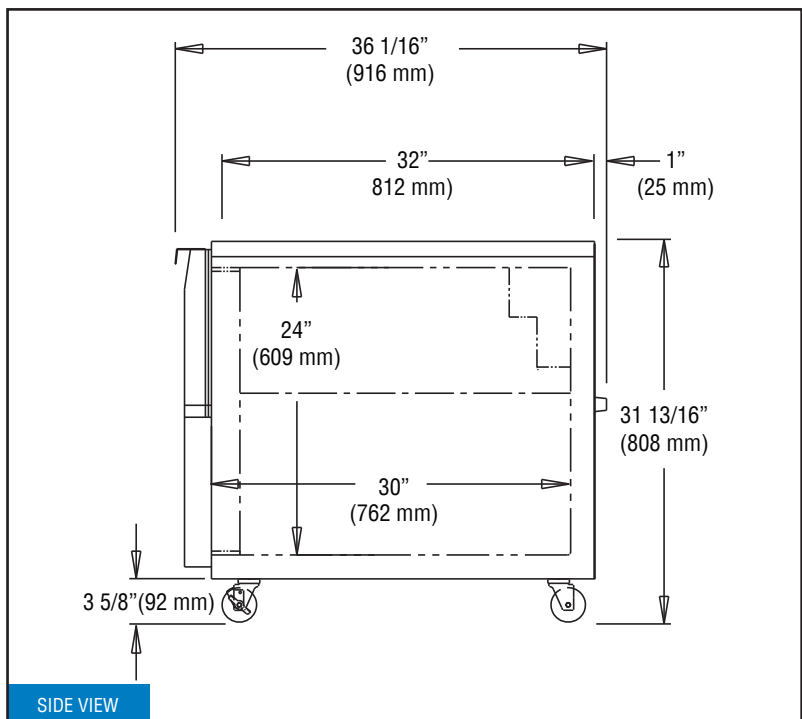
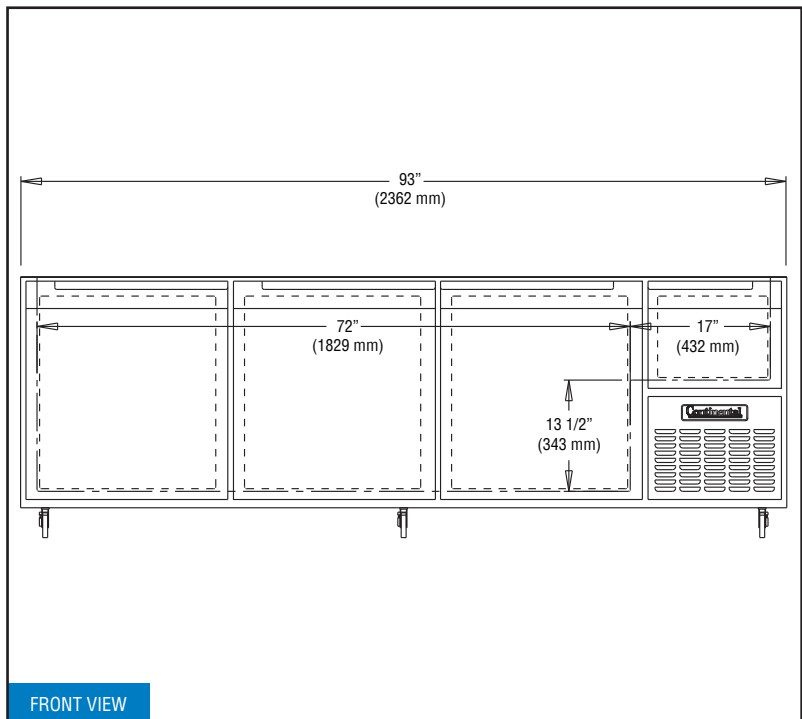

**Continental**  
Refrigerator

Toll-Free: 800-523-7138  
 Phone: 215-244-1400  
 Fax: 215-244-9579

539 Dunkserry Road  
 Bensalem, PA 19020  
[www.continentalrefrigerator.com](http://www.continentalrefrigerator.com)

Due to our continued efforts in developing innovative products, specifications subject to change without notice.



MADE IN THE U.S.A.

© Copyright 2014. Continental Refrigerator.  
 A Division of National Refrigeration & Air Conditioning Products, Inc.

CUFA93 (7/31/14)