

# GRIDDLE STAND REFRIGERATOR

**Model: DL48G**

## 48" Griddle Stand Refrigerator

Stainless steel exterior and interior.

Designed to maintain NSF-7 temperatures in 100°F ambient.



### Options and Accessories

(upcharge and lead times may apply)

Doors in lieu of drawers	Adjustable legs
Flat top in lieu of marine edge	Remote models
16-gauge stainless steel top (flat top only)	Digital thermometer
Condensing unit left or right	Cylinder locks
Automatic, electric condensate evaporator	Stainless steel pans
Stainless steel top extensions (flat or marine edge)	Special electrical requirements (consult factory)

Consult factory for other model configurations, options and accessories.

**Continental**  
Refrigerator

Toll-Free: 800-523-7138  
Phone: 215-244-1400  
Fax: 215-244-9579

539 Dunksferry Road  
Bensalem, PA 19020  
www.continentalrefrigerator.com

Project Name:

Model Specified:

Location:

Item No:

Quantity:

AIA #:

SIS #:

### Standard Model Features

#### REFRIGERATION SYSTEM

- Performance-rated refrigeration system
- Environmentally-safe R-134a refrigerant
- Side-mounted, automatic, energy saving non-electric condensate evaporator
- Non-corrosive, plasticized fin evaporator coil
- Easily serviceable, front slide-out condensing unit

#### CABINET ARCHITECTURE

- High density, non-CFC polyurethane foamed-in-place insulation
- Easy glide, fully extendable drawers designed to hold 6" deep pans side-by-side
- One-piece, snap-in magnetic drawer gaskets
- Heavy-duty drawer track with built-in drawer safety clips
- Drawers designed to hold 250 lb. capacity
- 4" casters on support plates
- Stainless steel case back
- Reinforced stainless steel work top with drip guard marine edge

#### MODEL FEATURES

- Capillary dial thermometer
- Front breathing

APPROVAL:

## Model Specifications

### DIMENSIONAL DATA

Net Capacity (cu. ft.)	9.0 (255 cu l)
Width, Overall (in.)	48 (1219 mm)
Depth, Overall (incl. handles) (in.)	34 3/4 (883 mm)
Height, Overall (in.) (incl. 4" casters)	26 3/8 (670 mm)
No. of Drawers	2

### REFRIGERANT DATA

Condensing Unit Size (H.P.)	1/5
Capacity (BTU/Hr)*	1725

### ELECTRICAL DATA

Voltage (int'l)	115/60/1 (220/50/1)
Fans	1
Feed Wires (incl. ground)	3
Total Amps (int'l)	5.7 (3.1)
10 ft. Cord/Plug [attached] (int'l)	Yes (No)

### SHIPPING DATA

Weight (lbs.)	450 (204 kg)
Height - Crated (in.)	44 (1118 mm)
Width - Crated (in.)	64 (1626 mm)
Depth - Crated (in.)	39 (991 mm)

### TOP WEIGHT CAPACITY

Max. Top Weight Capacity (lbs.)	775 (352 kg)
---------------------------------	--------------

\* Rating @ +25°F evaporator, 90°F ambient

Figures in parentheses reflect metric equivalents rounded to the nearest whole unit.



Equipped with one NEMA-5-15P Plug  
(varies by country)

**Continental**  
Refrigerator

Toll-Free: 800-523-7138  
Phone: 215-244-1400  
Fax: 215-244-9579

539 Dunkserry Road  
Bensalem, PA 19020  
[www.continentalrefrigerator.com](http://www.continentalrefrigerator.com)

Due to our continued efforts in developing innovative products, specifications subject to change without notice.



MADE IN THE U.S.A.

© Copyright 2014. Continental Refrigerator.  
A Division of National Refrigeration & Air Conditioning Products, Inc.

## Model Plan Views

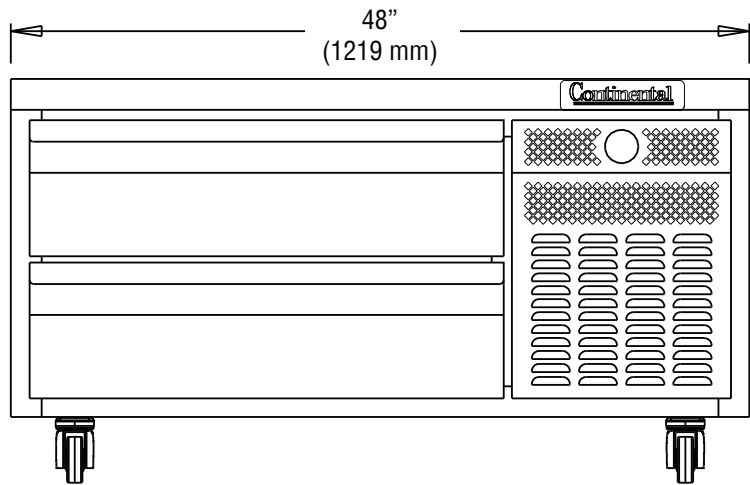

FRONT VIEW

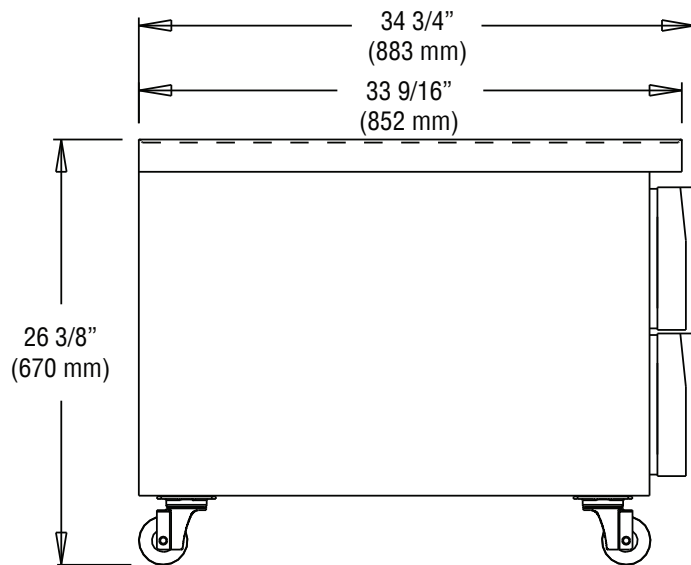

SIDE VIEW

Shown with (4) 12 x 20 x 6 pans (not furnished)

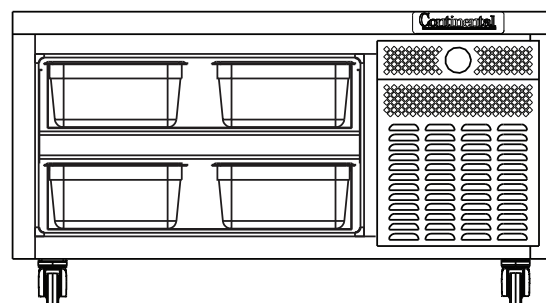

DRAWER PAN CONFIGURATION