

DESIGNER LINE WORKTOP FREEZER (0°F)

Model: DLF32-SS-U-D

32" Worktop Freezer with Drawers for Undercounter Applications

Stainless steel exterior and interior with stainless steel top.

Designed to maintain NSF-7 temperatures in 100°F ambient.



Options and Accessories

(upcharge and lead times may apply)

Solid door in lieu of drawers	Remote models
Automatic electric condensate evaporator	Drawer locks
Expansion valve system	Special electrical requirements (consult factory)

Consult factory for other model configurations, options and accessories.

Continental
Refrigerator

Toll-Free: 800-523-7138
Phone: 215-244-1400
Fax: 215-244-9579

539 Dunksferry Road
Bensalem, PA 19020
www.continentalrefrigerator.com

Project Name:

Model Specified:

Location:

Item No:

Quantity:

AIA #:

SIS #:

Standard Model Features

REFRIGERATION SYSTEM

Performance-rated refrigeration system

Environmentally-safe R-404A refrigerant

Automatic, energy-saving, non-electric condensate evaporator

Non-corrosive, plasticized fin evaporator coil

Easily serviceable back mounted compressor

CABINET ARCHITECTURE

2" non-CFC polyurethane foam insulation

Stainless steel roll-out drawers

Magnetic snap-in drawer gaskets

Completely enclosed, vented and removable case back

1 3/8" diameter plate casters (factory installed)

MODEL FEATURES

Interior hanging thermometer

2" high, bottom mounted front breather air divider

Automatic electric defrost

APPROVAL:

Model Specifications

DIMENSIONAL DATA

Net Capacity (cu. ft.)	9.0 (255 cu l)
Width, Overall (in.)	32 (813 mm)
Depth, Overall (in.) (incl. handle & bumpers)	31 3/16 (792 mm)
Height, Overall (in.) (incl. 1 3/8" plate casters)	31 13/16 (808 mm)
No. of Drawers (two tier)	2
No. of Drawers (three tier)	3

REFRIGERANT DATA

Condensing Unit Size (H.P.)	1/3
Capacity (BTU/Hr)*	1340

ELECTRICAL DATA

Voltage (int'l)	115/60/1 (220/50/1)
Fans	1
Total Amps (int'l)	5.8 (2.8)
Defrost Amps (int'l)	3.9 (2.0)
10 ft. Cord/Plug [attached] (int'l)	Yes (No)

SHIPPING DATA

Weight (lbs.)	240 (109 kg)
Height - Crated (in.)	43 1/4 (1099 mm)
Width - Crated (in.)	39 (991 mm)
Depth - Crated (in.)	37 1/4 (946 mm)

DRAWER PAN CONFIGURATIONS

Two Tier: (1) 12 x 20 x 6 pan per drawer
or (1) 1/2 size x 6 & (1) 1/3 size x 6 pan per drawer

Three Tier: (1) 12 x 20 x 4 pan per drawer
or (1) 1/2 size x 4 & (2) 1/3 size x 4 pans per drawer

* Rating @ -15°F evaporator, 90°F ambient

Figures in parentheses reflect metric equivalents rounded to the nearest whole unit.



Equipped with one NEMA-5-15P Plug
(varies by country)

Continental

Refrigerator

Toll-Free: 800-523-7138
Phone: 215-244-1400
Fax: 215-244-9579

539 Dunksferry Road
Bensalem, PA 19020
www.continentalrefrigerator.com

Due to our continued efforts in developing innovative products, specifications subject to change without notice.



MADE IN THE U.S.A.

© Copyright 2015, Continental Refrigerator.
A Division of National Refrigeration & Air Conditioning Products, Inc.

Model Plan Views

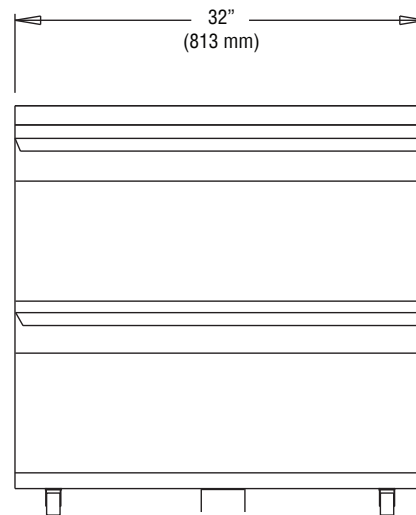

FRONT VIEW Note: Shown with two tier drawers.

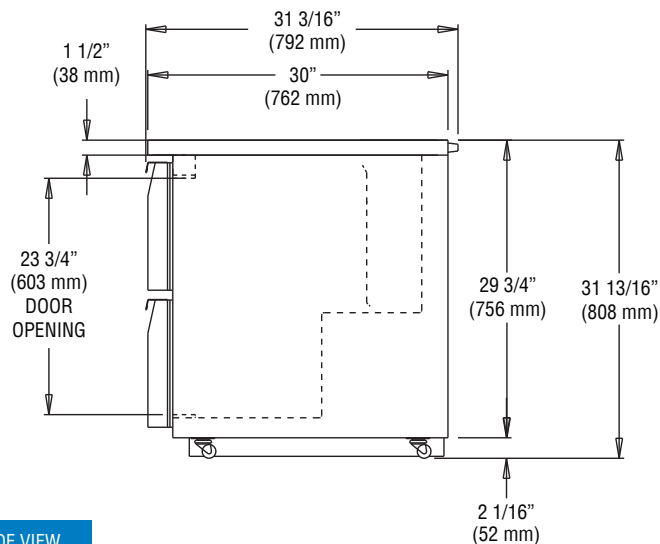

SIDE VIEW

REFRIGERATION SYSTEM

The self-contained refrigeration system is rear mounted, concealed behind a removable back cover. Bottom mounted, low-profile air divider allows for even air circulation to condensing unit. A "performance rated", air-cooled, hermetically sealed, expansion valve refrigeration system is installed in model. Plasticized finned coil and air circulating fans are contained within an easily accessible rear mounted housing. Our unique airflow design allows the cabinet to be enclosed on both sides or to be mounted flush against a wall.* Our refrigeration system, fully charged with R-404A refrigerant, is designed to maintain 0°F while operating with an unrestricted air supply in an ambient temperature of 100°F. All condensate water is directed to a non-electric condensate vaporizer located in the compressor compartment, no plumbing is required. A strict quality assurance team inspects all materials and components to certify that the model conforms to the most exacting standards. Model is performance tested for a minimum of 16 hours prior to crating.

INSULATION

All cabinet walls, top and bottom have high density, foamed-in-place, non-CFC polyurethane insulation.

*NOTE: For proper operation, the area under and in front of the cabinet **must** not be obstructed in any way.

CABINET CONSTRUCTION

Materials are top quality, assembled under rigid supervision conforming to strict quality assurance requirements. Case is welded metal construction, internally supported and braced for rigid unit construction. Exterior cabinet back and bottom are heavy gauge galvanized steel.

Design eliminates overlapping panels with raw edges. Interior corners are rounded with 1/4" radius. Joints and seams are vapor-tight sealed. Easily removable anti-sweat door heaters, concealed by non-metallic, non-conductive, high impact thermal breaker strips, eliminates condensation build-up on case front.

DRAWER CONSTRUCTION

Fronts/back are constructed of heavy-gauge, polished stainless steel with heavy-duty, safety grip, chrome plated handles. Drawer fronts are insulated with non-CFC polyurethane foam insulation. Full extension, lift-out frames are heavy gauge, welded stainless steel mounted on heavy-duty, easy glide, self closing slides. Self adjusting, full perimeter, magnetic snap-in gaskets guarantee a positive seal.