

DESIGNER LINE BASE MODEL

Model: DLRA43-SS-BS

43" Worktop Refrigerator with Solid Doors and 6" Backsplash

Stainless steel exterior front, sides and interior.

Designed to maintain NSF-7 temperatures in 100°F ambient.



Options and Accessories

(upcharge and lead times may apply)

| | |
|---|-------------------------------|
| Drawers in lieu of door | Stainless steel back |
| Drawer section above the condensing unit* | Condensing unit left or right |
| Overshelves (single or double) | Stainless steel pan slides |
| Additional epoxy-coated steel shelves | Remote models |
| Stainless steel shelves | Door locks |
| Automatic, electric condensate evaporator | Casters |
| Digital thermometer | Front breathing |

Drawer section above condensing unit holds (1) 12 x 20 x 6 pan.

Continental
Refrigerator

Toll-Free: 800-523-7138
Phone: 215-244-1400
Fax: 215-244-9579

539 Dunksferry Road
Bensalem, PA 19020
www.continentalrefrigerator.com

Project Name:

Model Specified:

Location:

Item No:

Quantity:

AIA #:

SIS #:

Standard Model Features

REFRIGERATION SYSTEM

Performance-rated refrigeration system

Environmentally-safe R-134a refrigerant

Unique forced air design utilizes fans (approx. every 12") across the entire back of unit for even distribution of cold

Automatic, energy saving, non-electric condensate evaporator

Non-corrosive, plasticized fin evaporator coil

Easily serviceable, slide-out condensing unit

CABINET ARCHITECTURE

2" non-CFC polyurethane foam insulation

Spring loaded, self closing doors

Magnetic snap-in door gaskets

Heavy-duty, epoxy-coated steel shelves

Adjustable 6" stainless steel legs

Completely enclosed, vented and removable rear and side grills

Refrigerated door section above the condensing unit

MODEL FEATURES

Expansion valve for quick recovery

Built-in, off cycle defrost timer

External dial thermometer

Field rehingable doors

NOTE: DLRA models come standard with a door over the condensing unit. A drawer over the condensing unit is an option.

APPROVAL:

Model Specifications

DIMENSIONAL DATA

| | |
|---|------------------|
| Net Capacity (cu. ft.) | 12 (340 cu l) |
| Width, Overall (in.) | 43 (1092 mm) |
| Depth, Overall (in.) (incl. handles & bumpers) | 36 1/16 (916 mm) |
| Height, Overall (in.) (incl. 6" legs) | 41 1/2 (1054 mm) |
| Shelf Area (sq. ft.) | 5.6 (.5 sq m) |
| No. of Shelves | 2 |
| No. of Full Doors | 1 |
| No. of Half Doors | 1 |
| Interior Depth (in.) | 30 (762 mm) |
| Interior Height (in.) | 26 (660 mm) |
| Interior Height (in.) (above condenser) | 12 1/2 (318 mm) |
| Interior Width (in.) | 39 (991 mm) |

REFRIGERANT DATA

| | |
|-----------------------------|------|
| Condensing Unit Size (H.P.) | 1/3 |
| Capacity (BTU/Hr)* | 2610 |

ELECTRICAL DATA

| | |
|-------------------------------------|---------------------|
| Voltage (int'l) | 115/60/1 (220/50/1) |
| Fans | 2 |
| Total Amps (int'l) | 6.0 (2.9) |
| 10 ft. Cord/Plug [attached] (int'l) | Yes (No) |

SHIPPING DATA

| | |
|-----------------------|------------------|
| Weight (lbs.) | 355 (161 kg) |
| Height - Crated (in.) | 43 3/4 (1111 mm) |
| Width - Crated (in.) | 45 (1143 mm) |
| Depth - Crated (in.) | 47 (1194 mm) |

* Rating @ +25°F evaporator, 90°F ambient

Figures in parentheses reflect metric equivalents rounded to the nearest whole unit.



Equipped with one NEMA-5-15P Plug
(varies by country)

Continental

Refrigerator

Toll-Free: 800-523-7138
Phone: 215-244-1400
Fax: 215-244-9579

539 Dunksferry Road
Bensalem, PA 19020
www.continentalrefrigerator.com

Due to our continued efforts in developing innovative products, specifications subject to change without notice.



MADE IN THE U.S.A.

© Copyright 2014. Continental Refrigerator.
A Division of National Refrigeration & Air Conditioning Products, Inc.

Model Plan Views

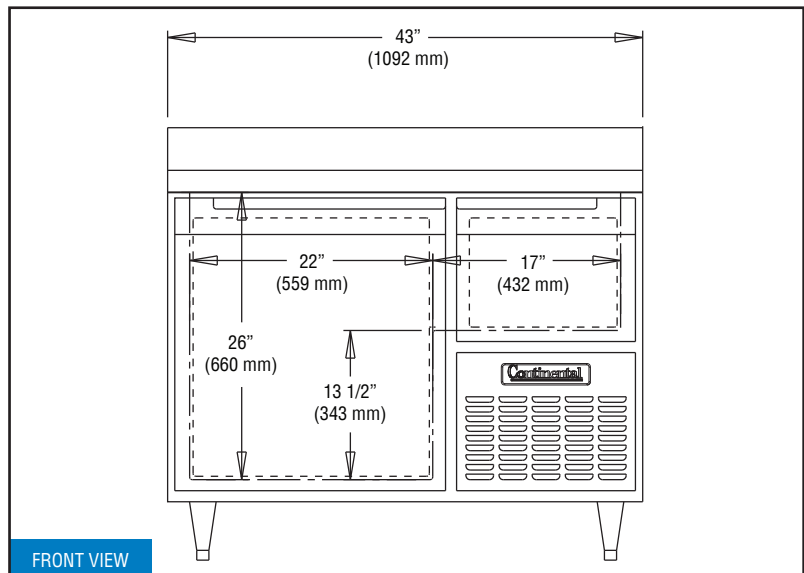

FRONT VIEW

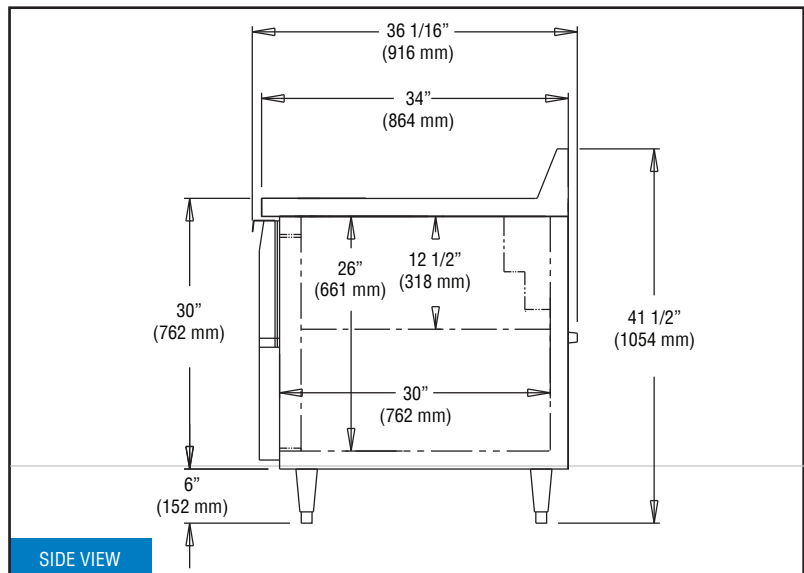

SIDE VIEW

REFRIGERATION SYSTEM

The self-contained refrigeration system is rear mounted, concealed behind a removable louvered cover. Full-length front air grille allows for even air circulation to condensing unit. A "performance rated", air-cooled, hermetically sealed, capillary type refrigeration system is installed in model. Plasticized finned coil and air circulating fans are contained within an easily accessible rear mounted housing. Our unique airflow design allows the cabinet to be enclosed on both sides or to be mounted flush against a wall. Our refrigeration system, fully charged with R-134a refrigerant, is designed to maintain 38°-41°F while operating with an unrestricted air supply in an ambient temperature of 100°F. All condensate water is directed to a non-electric condensate vaporizer located in the compressor compartment, no plumbing is required. A strict quality assurance team inspects all materials and components to certify that the model conforms to the most exacting standards. Model is performance tested for a minimum of 16 hours prior to crating.

INSULATION

All cabinet walls, top and bottom have high density, foamed-in-place, non-CFC polyurethane insulation.

DOOR CONSTRUCTION

Door shells are constructed of heavy-gauge stainless steel and are internally braced and urethane foam-insulated for rigidity. Door corners are of welded construction and polished. Replaceable snap-in door gaskets are self adjusting, heavy-duty, magnetic type. Door handles and hinges are chrome-plated and non-corrosive. Hinges are spring loaded, heavy duty and self-closing.

CABINET CONSTRUCTION

All materials are of top quality and are assembled under rigid supervision conforming to strict quality assurance requirements. Case is all welded metal construction and is internally supported and braced for rigid unit construction. Exterior, interior and worktop are heavy-gauge polished stainless steel for durability. Cabinet design eliminates overlapping panels with raw edges. Interior corners are rounded with a 1/4" radius for cleaning ease. All cabinet joints and seams are vapor-tight sealed. An easily removable anti-sweat drawer heater, concealed by a non-metallic, non-conductive, high impact thermal breaker strip, eliminates condensation build-up on case front.