

# COLD WALL MILK COOLERS

## Model: MC4-DCW

### 49" Cold Wall Milk Cooler Dual Access

White painted steel exterior, stainless steel top and doors, heavy-duty stainless steel lids, door hinges and latches, galvanized steel interior with reinforced stainless steel floor. **Designed to keep milk cold during serving.**



#### Options and Accessories

(upcharge and lead times may apply)

Stainless steel exterior	Adjustable legs
Stainless steel interior	Color laminate
Wrap around bumpers	Powder coating
Corner bumpers	Digital thermometer
Foot pedal floor lock	Single access

Consult factory for other model configurations, options and accessories.

**Continental**  
Refrigerator

Toll-Free: 800-523-7138  
Phone: 215-244-1400  
Fax: 215-244-9579

539 Dunksferry Road  
Bensalem, PA 19020  
[www.continentalrefrigerator.com](http://www.continentalrefrigerator.com)

Project Name:

Model Specified:

Location:

Item No:

Quantity:

AIA #:

SIS #:

#### Standard Model Features

##### REFRIGERATION SYSTEM

Cold wall, performance-rated refrigeration system

Environmentally-safe R-404A refrigerant

Easily serviceable, bottom-mounted compressor

##### CABINET ARCHITECTURE

2" high density, non-CFC polyurethane foamed-in-place insulation

Snap-in lids and door gaskets

Non-corrosive, heavy-duty, epoxy-coated steel wire floor racks

Door cylinder security locks

5" swivel casters w/ front locking brakes

##### MODEL FEATURES

Exterior-mounted dial thermometer

Floor drain

APPROVAL:

## Model Specifications

### DIMENSIONAL DATA

Net Capacity (cu. ft.)	20.0 (566 cu l)
Crate Capacity (13" x 13" x 11")	12
Crate Capacity (19" x 13" x 11")	8
Width, Overall (in.)	49 (1245 mm)
Depth, Overall (in.)	33 (838 mm)
Height, Overall (in.) (incl. 5" casters)	41 1/2 (1054 mm)

### REFRIGERANT DATA

Condensing Unit Size (H.P.)	1/3
Capacity (BTU/Hr)*	1725

### ELECTRICAL DATA

Voltage (int'l)	115/60/1 (220/50/1)
Total Amps (int'l)	5.6 (3.0)
10 ft. Cord/Plug [attached] (int'l)	Yes (No)

### SHIPPING DATA

Weight (lbs.)	470 (213 kg)
Height - Crated (in.)	56 1/4 (1429 mm)
Width - Crated (in.)	58 1/4 (1480 mm)
Depth - Crated (in.)	36 1/2 (927 mm)

\* Rating @ +10°F evaporator, 90°F ambient

Figures in parentheses reflect metric equivalents rounded to the nearest whole unit.



Equipped with one NEMA-5-15P Plug  
(varies by country)

## Model Plan Views

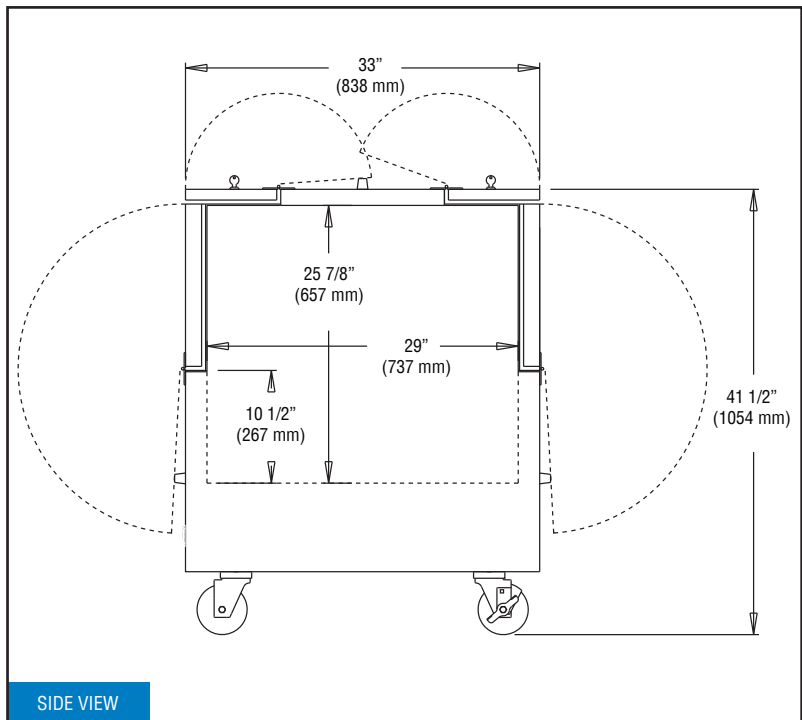
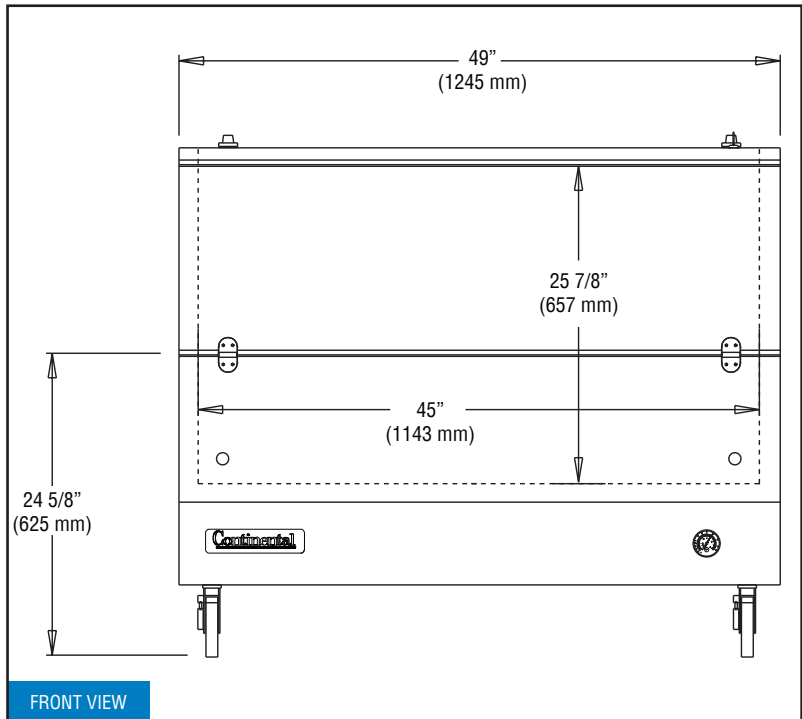

# Continental

Refrigerator

Toll-Free: 800-523-7138  
Phone: 215-244-1400  
Fax: 215-244-9579

539 Dunkserry Road  
Bensalem, PA 19020  
[www.continentalrefrigerator.com](http://www.continentalrefrigerator.com)

Due to our continued efforts in developing innovative products, specifications subject to change without notice.



MADE IN THE U.S.A.

© Copyright 2015. Continental Refrigerator.  
A Division of National Refrigeration & Air Conditioning Products, Inc.