

# FORCED AIR MILK COOLERS

## Model: MC4-SS-D

### 49" Forced Air Milk Cooler Dual Access

Stainless steel exterior and interior, heavy-duty stainless steel lids, door hinges and latches with reinforced stainless steel floor. **Designed to keep milk cold during serving.**



#### Options and Accessories

(upcharge and lead times may apply)

Wrap around bumpers	Color laminate
Corner bumpers	Powder coating
Foot pedal floor lock	Digital thermometer
Adjustable legs	Single access

Consult factory for other model configurations, options and accessories.

**Continental**  
Refrigerator

Toll-Free: 800-523-7138  
Phone: 215-244-1400  
Fax: 215-244-9579

539 Dunksferry Road  
Bensalem, PA 19020  
[www.continentalrefrigerator.com](http://www.continentalrefrigerator.com)

Project Name:

Model Specified:

Location:

Item No:

Quantity:

AIA #:

SIS #:

#### Standard Model Features

##### REFRIGERATION SYSTEM

Forced air, performance-rated refrigeration system  
Environmentally-safe R-134a refrigerant  
Easily serviceable, bottom-mounted compressor  
Built-in, electric condensate evaporator

##### CABINET ARCHITECTURE

2" high density, non-CFC polyurethane foamed-in-place insulation  
Snap-in lids and door gaskets  
Non-corrosive, heavy-duty, epoxy-coated steel wire floor racks  
Door cylinder security locks  
5" swivel casters w/ front locking brakes

##### MODEL FEATURES

Exterior-mounted dial thermometer  
Floor drain  
Unique forced air flow curtain

APPROVAL:

## Model Specifications

### DIMENSIONAL DATA

Net Capacity (cu. ft.)	20.0 (566 cu l)
Crate Capacity (13" x 13" x 11")	12
Crate Capacity (19" x 13" x 11")	8
Width, Overall (in.)	49 (1245 mm)
Depth, Overall (in.)	33 (838 mm)
Height, Overall (in.) (incl. 5" casters)	47 (1194 mm)

### REFRIGERANT DATA

Condensing Unit Size (H.P.)	1/3
Capacity (BTU/Hr)*	2620

### ELECTRICAL DATA

Voltage (int'l)	115/60/1 (220/50/1)
Total Amps (int'l)	7.4 (4.3)
10 ft. Cord/Plug [attached] (int'l)	Yes (No)

### SHIPPING DATA

Weight (lbs.)	470 (213 kg)
Height - Crated (in.)	56 1/4 (1429 mm)
Width - Crated (in.)	58 1/4 (1480 mm)
Depth - Crated (in.)	36 1/2 (927 mm)

\* Rating @ +25°F evaporator, 90°F ambient

Figures in parentheses reflect metric equivalents rounded to the nearest whole unit.



Equipped with one NEMA-5-15P Plug  
(varies by country)

## Model Plan Views

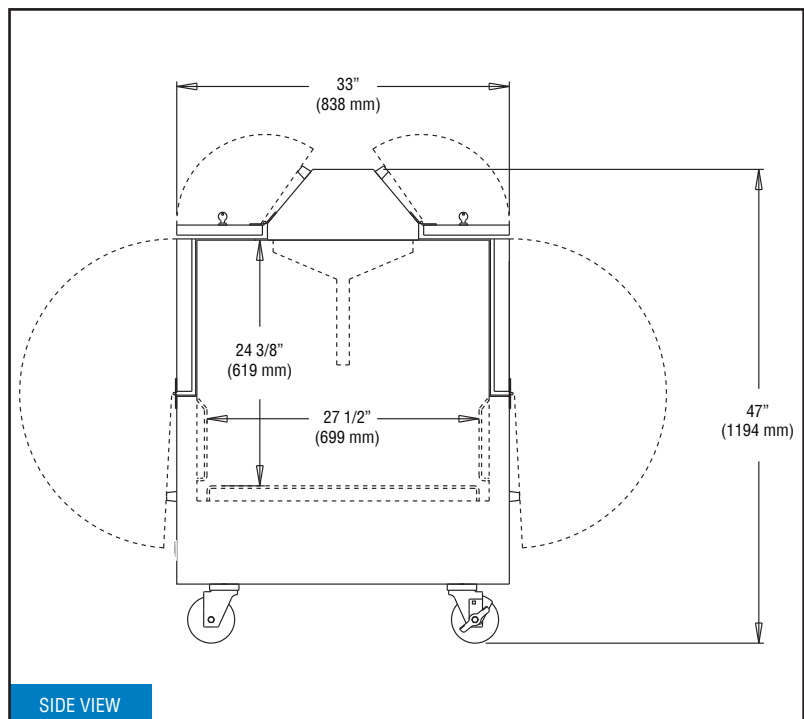
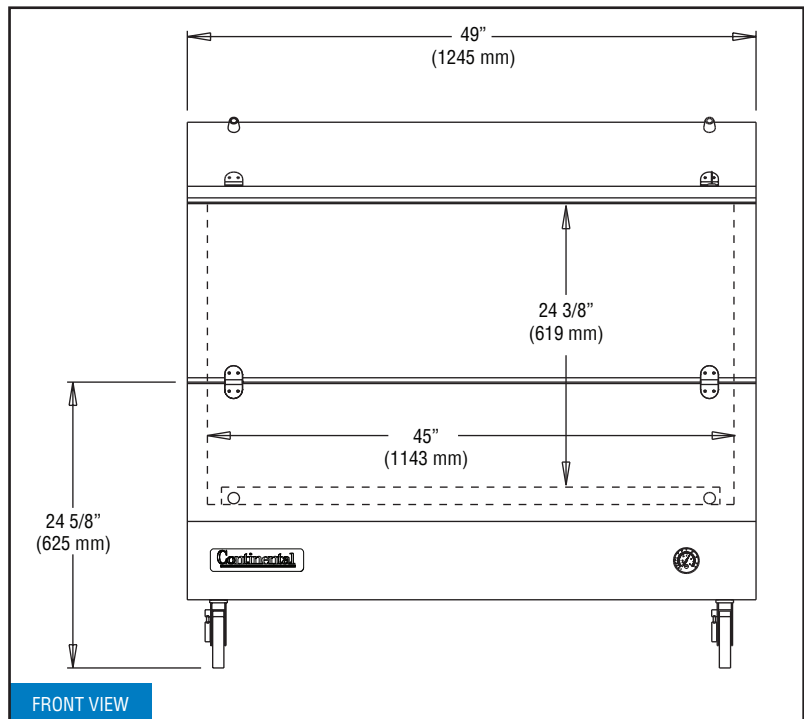

# Continental

Refrigerator

Toll-Free: 800-523-7138  
Phone: 215-244-1400  
Fax: 215-244-9579

539 Dunkserry Road  
Bensalem, PA 19020  
[www.continentalrefrigerator.com](http://www.continentalrefrigerator.com)

Due to our continued efforts in developing innovative products, specifications subject to change without notice.



MADE IN THE U.S.A.

© Copyright 2015, Continental Refrigerator.  
A Division of National Refrigeration & Air Conditioning Products, Inc.