

# SANDWICH UNIT REFRIGERATOR

**Model: SW48-18M-D**

## 48" Mighty Top Sandwich Unit Refrigerator with Drawers - 18 Pans

Stainless steel front and top, aluminum end panels, case back and interior.  
**Certified under NSF-7 to maintain temperatures in 86°F ambient and designed to maintain NSF-7 temperatures in 100°F ambient.**



### Options and Accessories

(upcharge and lead times may apply)

|   |                            |
|---|----------------------------|
| Stainless steel exterior and interior - SS models | Rear-mounted cutting board |
| Stainless steel end panels - SA models            | Flat insulated night cover |
| Glass doors in lieu of drawers - GD models        | Remote models              |
| Stainless steel finished back in lieu of aluminum | Drawer locks               |
| Solid doors in lieu of drawers                    | Adjustable legs            |
| Overshelves (single or double)                    | Digital thermometer        |
| Automatic, electric condensate evaporator         | Crumb catcher              |
| Expansion valve system                            | Three tier drawers         |

Consult factory for other model configurations, options and accessories.

**Continental**  
 Refrigerator

Toll-Free: 800-523-7138  
 Phone: 215-244-1400  
 Fax: 215-244-9579

539 Dunksferry Road  
 Bensalem, PA 19020  
[www.continentalrefrigerator.com](http://www.continentalrefrigerator.com)

Project Name:

Model Specified:

Location:

Item No:

Quantity:

AIA #:

SIS #:

### Standard Model Features

#### REFRIGERATION SYSTEM

- Performance-rated refrigeration system
- Environmentally-safe R-134a refrigerant
- Unique air flow distribution allows pan product to maintain 33° - 41°F
- Automatic, energy saving, non-electric condensate evaporator
- Non-corrosive, plasticized fin evaporator coil
- Easily serviceable, back mounted compressor

#### CABINET ARCHITECTURE

- 2" non-CFC polyurethane foam insulation
- Magnetic snap-in drawer gaskets
- 10" deep, full length nylon cutting board
- Stainless steel roll-out drawers
- Insulated lid
- 5" casters
- Completely enclosed, vented and removable case back

#### MODEL FEATURES

- (18) 1/6 size non-recessed pans, 4" deep
- Interior hanging thermometer

APPROVAL:

## Model Specifications

### DIMENSIONAL DATA

|   |                  |
|---|------------------|
| Net Capacity (cu. ft.)                            | 13.4 (379 cu l)  |
| 1/6 Size Pans (4" deep)                           | 18               |
| Width, Overall (in.)                              | 48 (1219 mm)     |
| Depth, Overall (in.)<br>(incl. handles & bumpers) | 35 (889 mm)      |
| Depth, Body Only<br>(less drawers) (in.)          | 27 1/2 (699 mm)  |
| Depth, Cutting Board (in.)                        | 10 (254 mm)      |
| Height, Overall (in.)<br>(incl. 5" casters)       | 42 1/4 (1073 mm) |
| No. of Drawers (two tier)                         | 4                |
| No. of Drawers (three tier)                       | 6                |

### REFRIGERANT DATA

|                             |      |
|-----------------------------|------|
| Condensing Unit Size (H.P.) | 1/5  |
| Capacity (BTU/Hr)*          | 1620 |

### ELECTRICAL DATA

|                                     |                     |
|-------------------------------------|---------------------|
| Voltage (int'l)                     | 115/60/1 (220/50/1) |
| Fans                                | 3                   |
| Total Amps (int'l)                  | 7.3 (3.6)           |
| 10 ft. Cord/Plug [attached] (int'l) | Yes (No)            |

### SHIPPING DATA

|                       |                  |
|-----------------------|------------------|
| Weight (lbs.)         | 285 (129 kg)     |
| Height - Crated (in.) | 43 1/4 (1099 mm) |
| Width - Crated (in.)  | 64 (1626 mm)     |
| Depth - Crated (in.)  | 46 (1168 mm)     |

### DRAWER PAN CONFIGURATIONS

**Two Tier:** (1) 12 x 18 x 6 pan per drawer  
or (1) 1/2 size x 6 & (1) 1/3 x 6 pans per drawer

**Three Tier:** (1) 12 x 18 x 3 1/2 pan per drawer  
or (1) 1/2 size x 4 & (1) 1/3 x 4 pans per drawer

\* Rating @ +25°F evaporator, 90°F ambient  
Figures in parentheses reflect metric equivalents rounded to the nearest whole unit.



Equipped with one NEMA-5-15P Plug  
(varies by country)

# Continental

Refrigerator

Toll-Free: 800-523-7138  
Phone: 215-244-1400  
Fax: 215-244-9579

539 Dunksferry Road  
Bensalem, PA 19020  
[www.continentalrefrigerator.com](http://www.continentalrefrigerator.com)

Due to our continued efforts in developing innovative products, specifications subject to change without notice.



MADE IN THE U.S.A.

© Copyright 2014. Continental Refrigerator.  
A Division of National Refrigeration & Air Conditioning Products, Inc.

## Model Plan Views

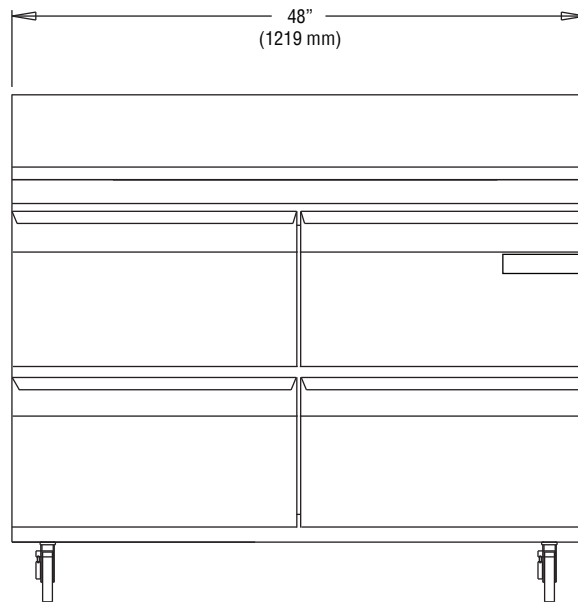

FRONT VIEW

Note: Shown with two tier drawers.

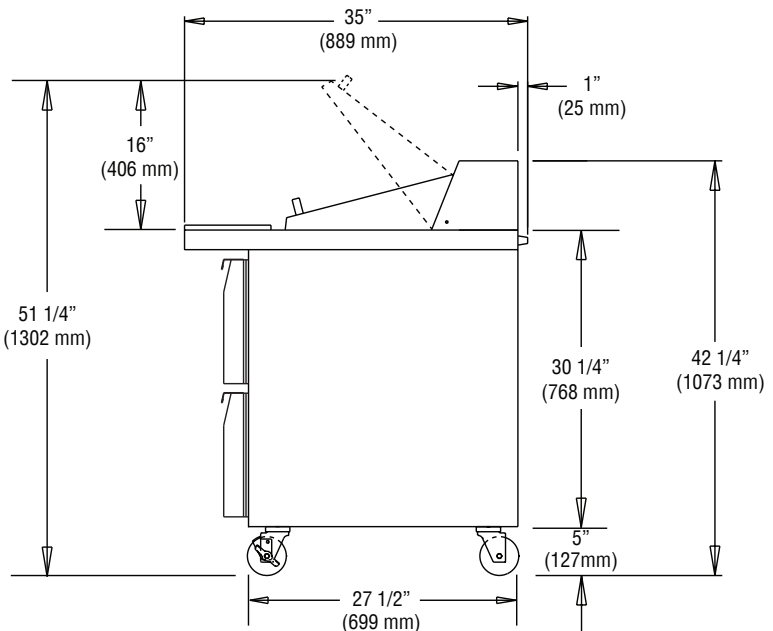

SIDE VIEW

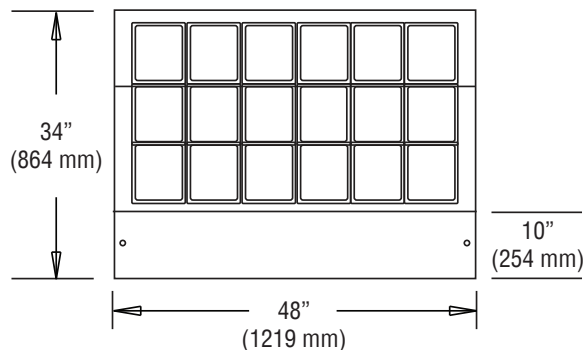

PAN TOP CONFIGURATION