

WORKTOP FREEZER (0°F)

Model: SWF27-BS-D

27" Worktop Freezer with Drawers and 6" Backsplash

Stainless steel front and top, aluminum end panels, case back and interior.

Designed to maintain NSF-7 temperatures in 100°F ambient.



Options and Accessories

(upcharge and lead times may apply)

Stainless steel exterior and interior	Glass door - GD models
Stainless back in lieu of aluminum	Adjustable legs
Overshelves (single or double)	Remote models
Automatic electric condensate evaporator	Drawers locks
Door in lieu of drawers	Digital thermometer
Expansion valve system	Special electrical requirements (consult factory)

Consult factory for other model configurations, options and accessories.

Continental
Refrigerator

Toll-Free: 800-523-7138
Phone: 215-244-1400
Fax: 215-244-9579

539 Dunksferry Road
Bensalem, PA 19020
www.continentalrefrigerator.com

Project Name:

Model Specified:

Location:

Item No:

Quantity:

AIA #:

SIS #:

Standard Model Features

REFRIGERATION SYSTEM

- Performance-rated refrigeration system
- Environmentally-safe R-404A refrigerant
- Automatic, energy-saving, non-electric condensate evaporator
- Non-corrosive, plasticized fin evaporator coil
- Easily serviceable back mounted compressor

CABINET ARCHITECTURE

- 2" non-CFC polyurethane foam insulation
- Stainless steel roll-out drawers
- Magnetic snap-in drawer gaskets
- Completely enclosed, vented and removable case back
- 5" casters

MODEL FEATURES

- Interior hanging thermometer
- Automatic electric defrost

APPROVAL:

Model Specifications

DIMENSIONAL DATA

Net Capacity (cu. ft.)	7.4 (210 cu l)
Width, Overall (in.)	27 1/2 (699 mm)
Depth, Overall (in.) (incl. handle & bumpers)	31 7/16 (799 mm)
Depth, Body Only (less drawers) (in.)	27 1/2 (699 mm)
Height, Overall (in.) (incl. 5" casters)	40 3/4 (1035 mm)
No. of Drawers (two tier)	2
No. of Drawers (three tier)	3

REFRIGERANT DATA

Condensing Unit Size (H.P.)	1/3
Capacity (BTU/Hr)*	1340

ELECTRICAL DATA

Voltage (int'l)	115/60/1 (220/50/1)
Fans	1
Total Amps (int'l)	5.8 (2.8)
Defrost Amps (int'l)	3.9 (2.0)
10 ft. Cord/Plug [attached] (int'l)	Yes (No)

SHIPPING DATA

Weight (lbs.)	170 (77 kg)
Height - Crated (in.)	43 1/4 (1099 mm)
Width - Crated (in.)	35 3/4 (908 mm)
Depth - Crated (in.)	37 1/4 (946 mm)

DRAWER PAN CONFIGURATIONS

Two Tier: (1) 12 x 20 x 6 pan per drawer

Three Tier: (1) 12 x 20 x 4 pan per drawer

* Rating @ -15°F evaporator, 90°F ambient

Figures in parentheses reflect metric equivalents rounded to the nearest whole unit.



Equipped with one NEMA-5-15P Plug
(varies by country)

Model Plan Views

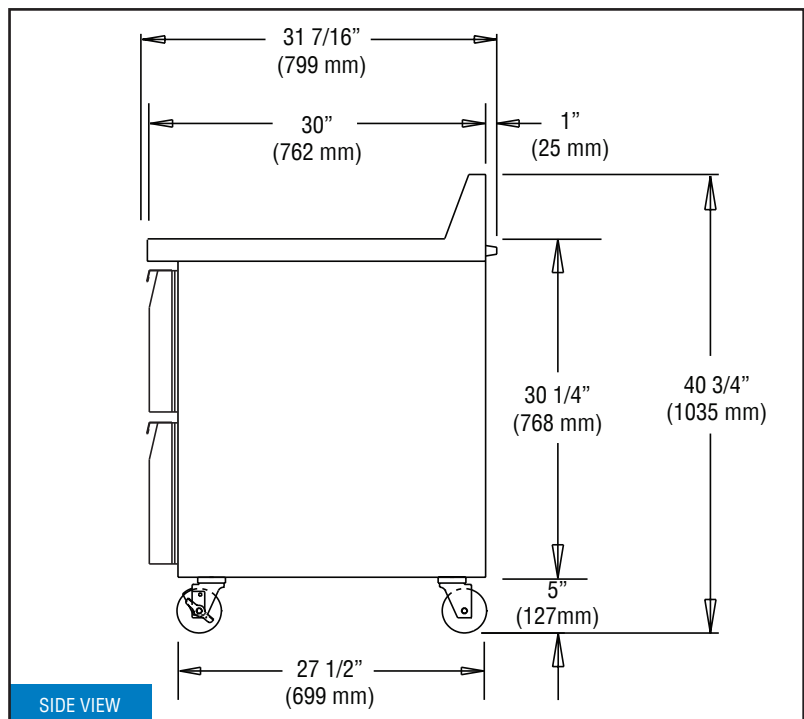
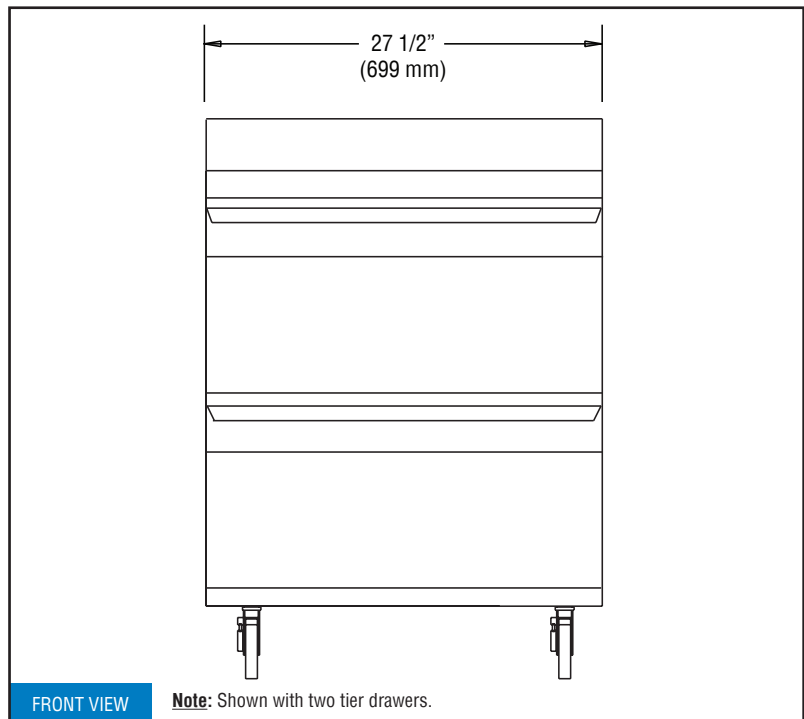

Continental
Refrigerator

Toll-Free: 800-523-7138
Phone: 215-244-1400
Fax: 215-244-9579

539 Dunkserry Road
Bensalem, PA 19020
www.continentalrefrigerator.com

Due to our continued efforts in developing innovative products, specifications subject to change without notice.



MADE IN THE U.S.A.

© Copyright 2013. Continental Refrigerator.
A Division of National Refrigeration & Air Conditioning Products, Inc.

SWF27-BS-D (11/14/13)