

WORKTOP FREEZER (0°F)

Model: SWF27-FB-D

27" Worktop Freezer with Drawers Front Breathing

Stainless steel front and top, aluminum end panels, case back and interior.

Designed to maintain NSF-7 temperatures in 100°F ambient.



Options and Accessories

(upcharge and lead times may apply)

Stainless steel exterior and interior	Glass door - GD models
Stainless back in lieu of aluminum	Expansion valve system
Overshelves (single or double)	Remote models
Automatic electric condensate evaporator	Drawers locks
Door in lieu of drawers	Digital thermometer
Backsplash - BS models	Special electrical requirements (consult factory)

Consult factory for other model configurations, options and accessories.

Continental
Refrigerator

Toll-Free: 800-523-7138
Phone: 215-244-1400
Fax: 215-244-9579

539 Dunksferry Road
Bensalem, PA 19020
www.continentalrefrigerator.com

Project Name:

Model Specified:

Location:

Item No:

Quantity:

AIA #:

SIS #:

Standard Model Features

REFRIGERATION SYSTEM

Performance-rated refrigeration system

Environmentally-safe R-404A refrigerant

Automatic, energy-saving, non-electric
condensate evaporator

Non-corrosive, plasticized fin evaporator coil

Easily serviceable back mounted compressor

CABINET ARCHITECTURE

2" non-CFC polyurethane foam insulation

Stainless steel roll-out drawers

Magnetic snap-in drawer gaskets

Completely enclosed, vented and removable case back

3 5/8" casters

MODEL FEATURES

Interior hanging thermometer

Automatic electric defrost

Front breathers are a unique, field assembled, bottom mounted ventilation system designed to allow cabinets to be flush against a wall or built into a counter to conserve space.

APPROVAL:

Model Specifications

DIMENSIONAL DATA

Net Capacity (cu. ft.)	7.4 (210 cu l)
Width, Overall (in.)	27 1/2 (699 mm)
Depth, Overall (in.) (incl. handle & bumpers)	31 7/16 (799 mm)
Depth, Body Only (less drawers) (in.)	27 1/2 (699 mm)
Height, Overall (in.) (incl. 3 5/8" casters)	33 7/8 (860 mm)
No. of Drawers (two tier)	2
No. of Drawers (three tier)	3

REFRIGERANT DATA

Condensing Unit Size (H.P.)	1/3
Capacity (BTU/Hr)*	1340

ELECTRICAL DATA

Voltage (int'l)	115/60/1 (220/50/1)
Fans	1
Total Amps (int'l)	5.8 (2.8)
Defrost Amps (int'l)	3.9 (2.0)
10 ft. Cord/Plug [attached] (int'l)	Yes (No)

SHIPPING DATA

Weight (lbs.)	165 (75 kg)
Height - Crated (in.)	43 1/4 (1099 mm)
Width - Crated (in.)	35 3/4 (908 mm)
Depth - Crated (in.)	37 1/4 (946 mm)

DRAWER PAN CONFIGURATIONS

Two Tier: (1) 12 x 20 x 6 pan per drawer

Three Tier: (1) 12 x 20 x 4 pan per drawer

* Rating @ -15°F evaporator, 90°F ambient

Figures in parentheses reflect metric equivalents rounded to the nearest whole unit.



Equipped with one NEMA-5-15P Plug
(varies by country)

Model Plan Views

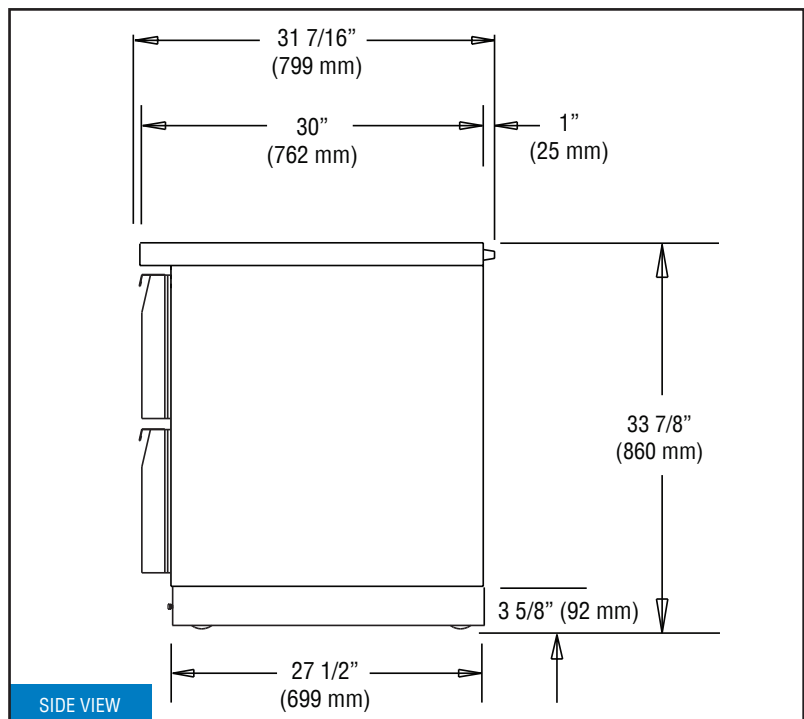
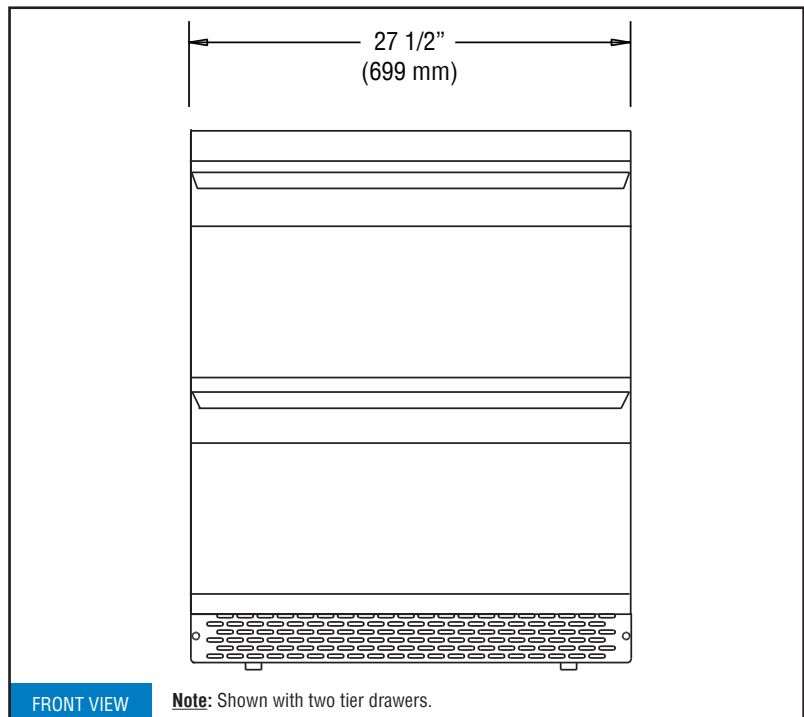

Continental

Refrigerator

Toll-Free: 800-523-7138
Phone: 215-244-1400
Fax: 215-244-9579

539 Dunkserry Road
Bensalem, PA 19020
www.continentalrefrigerator.com

Due to our continued efforts in developing innovative products, specifications subject to change without notice.



MADE IN THE U.S.A.

© Copyright 2013. Continental Refrigerator.
A Division of National Refrigeration & Air Conditioning Products, Inc.

SWF27-FB-D (11/15/13)