

WORKTOP FREEZER (0°F)

Model: SWF27-U-D

27" Worktop Freezer with Drawers for Undercounter Applications

Stainless steel front and top, aluminum end panels, case back and interior.

Designed to maintain NSF-7 temperatures in 100°F ambient.



Options and Accessories

(upcharge and lead times may apply)

Stainless steel exterior and interior - SS models	Remote models
Glass door in lieu of drawers - GD models	Drawer locks
Solid door in lieu of drawers	Special electrical requirements (consult factory)

Consult factory for other model configurations, options and accessories.

Continental
Refrigerator

Toll-Free: 800-523-7138
Phone: 215-244-1400
Fax: 215-244-9579

539 Dunksferry Road
Bensalem, PA 19020
www.continentalrefrigerator.com

Project Name:

Model Specified:

Location:

Item No:

Quantity:

AIA #:

SIS #:

Standard Model Features

REFRIGERATION SYSTEM

Performance-rated refrigeration system
Environmentally-safe R-134a refrigerant
Automatic, hot gas condensate evaporator
Non-corrosive, plasticized fin evaporator coil
Easily serviceable back mounted compressor

CABINET ARCHITECTURE

2" non-CFC polyurethane foam insulation
Stainless steel roll-out drawers
Magnetic snap-in drawer gaskets
Completely enclosed, vented and removable case back
1 3/8" diameter plate casters (factory installed)

MODEL FEATURES

Interior digital thermometer
2" high, bottom mounted front breather air divider
Automatic electric defrost
Expansion valve system

APPROVAL:

Model Specifications

DIMENSIONAL DATA

Net Capacity (cu. ft.)	7.4 (210 cu l)
Width, Overall (in.)	27 1/2 (699 mm)
Depth, Overall (in.) (incl. handle & bumpers)	31 3/16 (792 mm)
Height, Overall (in.) (incl. 1 3/8" plate casters)	31 13/16 (808 mm)
No. of Drawers (two tier)	2
No. of Drawers (three tier)	3

REFRIGERANT DATA

Condensing Unit Size (H.P.)	1/4
Capacity (BTU/Hr)*	1325

ELECTRICAL DATA

Voltage (int'l)	115/60/1 (n/a)
Fans	1
Total Amps (int'l)	4.8 (n/a)
Defrost Amps (int'l)	5.7 (n/a)
10 ft. Cord/Plug [attached] (int'l)	Yes (n/a)

SHIPPING DATA

Weight (lbs.)	165 (75 kg)
Height - Crated (in.)	43 1/4 (1099 mm)
Width - Crated (in.)	35 3/4 (908 mm)
Depth - Crated (in.)	37 1/4 (946 mm)

DRAWER PAN CONFIGURATIONS

Two Tier: (1) 12 x 20 x 6 pan per drawer

Three Tier: (1) 12 x 20 x 4 pan per drawer

* Rating @ -15°F evaporator, 90°F ambient

Figures in parentheses reflect metric equivalents rounded to the nearest whole unit.



Equipped with one NEMA-5-15P Plug
(varies by country)

Model Plan Views

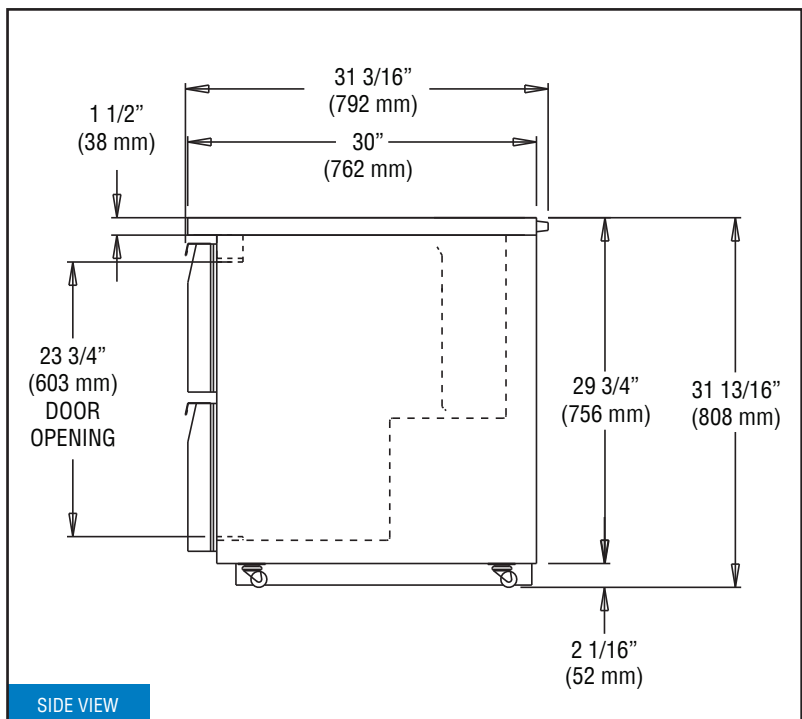
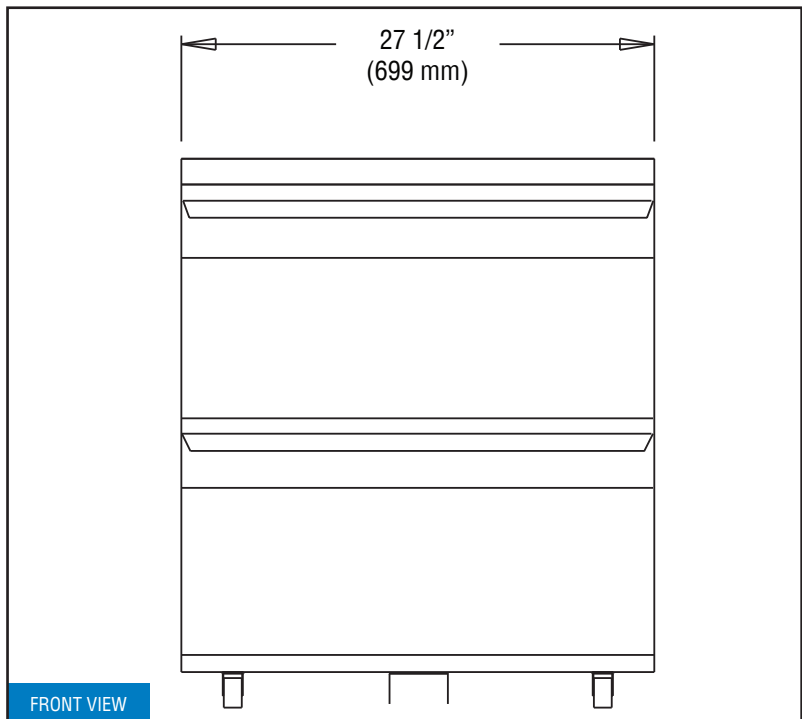

Continental
Refrigerator

Toll-Free: 800-523-7138
Phone: 215-244-1400
Fax: 215-244-9579

539 Dunkserry Road
Bensalem, PA 19020
www.continentalrefrigerator.com

Due to our continued efforts in developing innovative products, specifications subject to change without notice.



MADE IN THE U.S.A.

© Copyright 2015. Continental Refrigerator.
A Division of National Refrigeration & Air Conditioning Products, Inc.