

WORKTOP FREEZER (0°F)

Model: SWF36-U

36" Worktop Freezer with Solid Doors for Undercounter Applications

Stainless steel front and top, aluminum end panels, case back and interior.

Designed to maintain NSF-7 temperatures in 100°F ambient.



Options and Accessories

(upcharge and lead times may apply)

Stainless steel exterior and interior - SS models	Expansion valve system
Additional epoxy-coated steel shelves	Remote models
Automatic electric condensate evaporator	Door locks
Stainless steel shelves	Special electrical requirements (consult factory)

Consult factory for other model configurations, options and accessories.

Project Name:

Model Specified:

Location:

Item No:

Quantity:

AIA #:

SIS #:

Standard Model Features

REFRIGERATION SYSTEM

- Performance-rated refrigeration system
- Environmentally-safe R-404A refrigerant
- Automatic, energy-saving, non-electric condensate evaporator
- Non-corrosive, plasticized fin evaporator coil
- Easily serviceable back mounted compressor

CABINET ARCHITECTURE

- 2" non-CFC polyurethane foam insulation
- Spring loaded, self closing doors
- Magnetic snap-in door gaskets
- Heavy-duty, epoxy-coated steel shelves
- Completely enclosed, vented and removable case back
- 1 3/8" diameter plate casters (factory installed)

MODEL FEATURES

- Interior hanging thermometer
- 2" high, bottom mounted front breather air divider
- Automatic electric defrost
- Field rehingeable doors

Continental
Refrigerator

Toll-Free: 800-523-7138
Phone: 215-244-1400
Fax: 215-244-9579

539 Dunksferry Road
Bensalem, PA 19020
www.continentalrefrigerator.com

APPROVAL:

Model Specifications

DIMENSIONAL DATA

Net Capacity (cu. ft.)	10.3 (292 cu l)
Width, Overall (in.)	36 (914 mm)
Depth, Overall (in.) (incl. handles & bumpers)	31 3/16 (792 mm)
Height, Overall (in.) (incl. 1 3/8" plate casters)	31 13/16 (808 mm)
Shelf Area (sq. ft.)	4.6 (.4 sq m)
No. of Shelves	2
No. of Doors	2
Interior Depth (in.)	See Drawing
Interior Height (in.)	26 1/4 (667 mm)
Interior Width (in.)	32 (813 mm)

REFRIGERANT DATA

Condensing Unit Size (H.P.)	1/3
Capacity (BTU/Hr)*	1340

ELECTRICAL DATA

Voltage (int'l)	115/60/1 (220/50/1)
Fans	1
Total Amps (int'l)	5.8 (2.8)
Defrost Amps (int'l)	3.9 (2.0)
10 ft. Cord/Plug [attached] (int'l)	Yes (No)

SHIPPING DATA

Weight (lbs.)	239 (108 kg)
Height - Crated (in.)	43 1/4 (1099 mm)
Width - Crated (in.)	43 (1092 mm)
Depth - Crated (in.)	37 1/4 (946 mm)

* Rating @ -15°F evaporator, 90°F ambient
 Figures in parentheses reflect metric equivalents rounded to the nearest whole unit.



Equipped with one NEMA-5-15P Plug
 (varies by country)

Model Plan Views

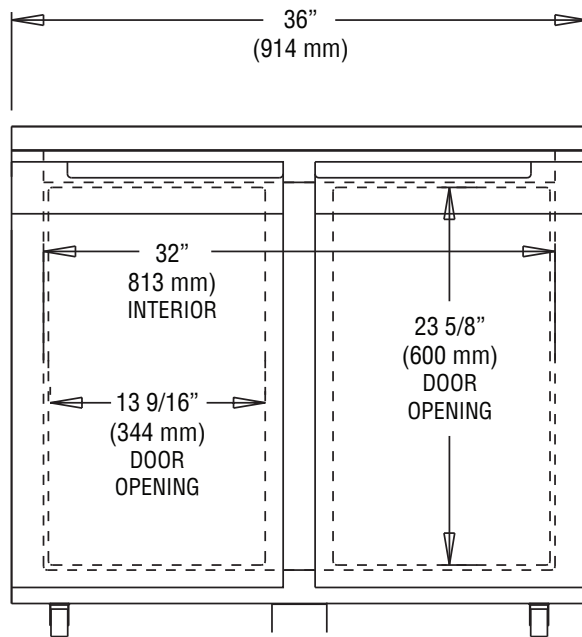

FRONT VIEW

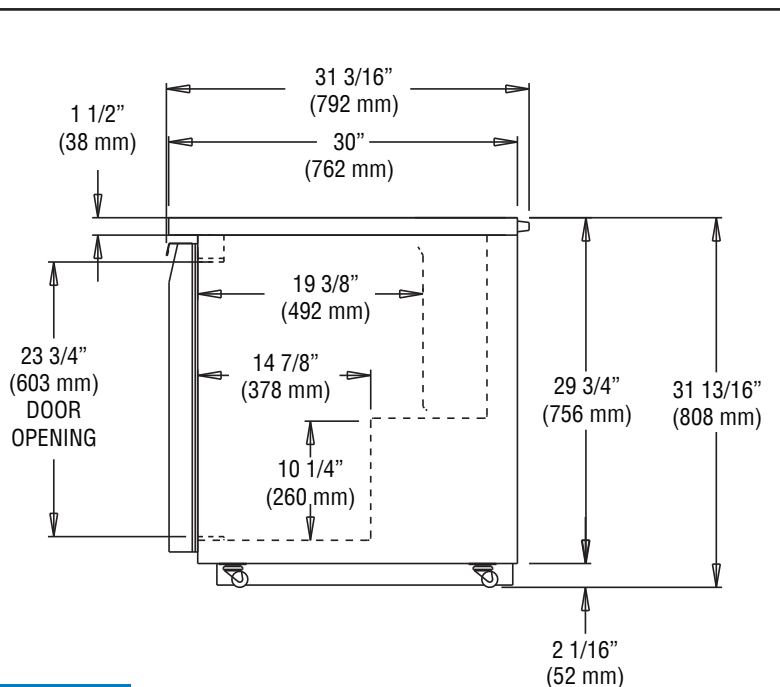

SIDE VIEW

Continental
 Refrigerator

Toll-Free: 800-523-7138
 Phone: 215-244-1400
 Fax: 215-244-9579

539 Dunkserry Road
 Bensalem, PA 19020
www.continentalrefrigerator.com

Due to our continued efforts in developing innovative products, specifications subject to change without notice.



MADE IN THE U.S.A.

© Copyright 2015. Continental Refrigerator.
 A Division of National Refrigeration & Air Conditioning Products, Inc.