



*Energy*  
**MIZER®**

**DOUBLE RACK  
MODEL B  
ENERGY SAVER  
(extended wrapper)**

**.96**  
Gallons Of Water  
Per Rack!



**MODEL B  
ENERGY SAVER  
(Extended Wrapper)**

**FEATURES:**

- 80 racks / 320 covers per hour.
- Large 20-1/2" clearance for dishes.
- Economical to operate. Uses as little as .96 gallons of water per rack.
- All stainless steel construction assures long life and years of trouble free operation.
- Unique spray arm system features upper and lower stainless steel wash arms with reinforced end caps. Specially designed pull-pins allow wash arms to be easily removed for cleaning.
- Pump purging system improves results by eliminating soil and chemical carryover during rinse cycle.
- Top mounted controls include built-in chemical pumps and deliming system that assures proper chemical usage.
- Auto start/stop makes operation safe and easy.
- Integrated scrap accumulator prevents food soil from entering drain system.
- Water inlet comes with built-in strainer, prevents debris from clogging the water valve.
- Dishmachine comes with 2 dishracks.
- Stainless steel impeller offers extended life and service.
- Stainless steel scrap tray long lasting.

**Available Options**

- Solid/Powder Dual Bowl Dispenser
- CMA Temp-Sure™  
(Self contained 12kW heater)
- Sanitizer Alarm
- Alternative Cycle Times
- Alternative Voltages Available
- Stainless Steel Tables
- Stainless Steel Scrap Trap
- Slant Shelf 21"X42"



Optional Temp-Sure™ heater assures a continuous supply of 140°F hot water that guarantees excellent results.

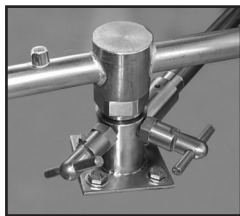

Unique pull-pin design allows wash arms to be easily removed for cleaning.



Sanitizer Alarm System is an audible alarm and warning light feature that gives a warning when sanitizer product is nearly empty.



Top mounted controls include built-in chemical pumps and deliming system that assures proper chemical usage.

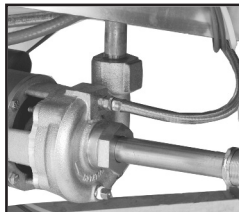

Pump purging system improves results by eliminating soil and chemical carryover during rinse cycle.



**LISTED**  
COMMERCIAL  
DISHWASHER  
864T



CMA Dishmachines 12700 Knott Street Garden Grove, CA 92841 • 800-854-6417 • 714-898-8781 • Fax: 714-895-2141 • www.cmadishmachines.com

CMA reserves the right to modify specifications or discontinue models without prior notification.



**DOUBLE RACK  
MODEL B  
ENERGY SAVER  
(extended wrapper)**

**WARNING:** Plumbing connections must be made by a qualified service company who will comply with all available Federal, State, and Local Health, Plumbing and Safety codes.

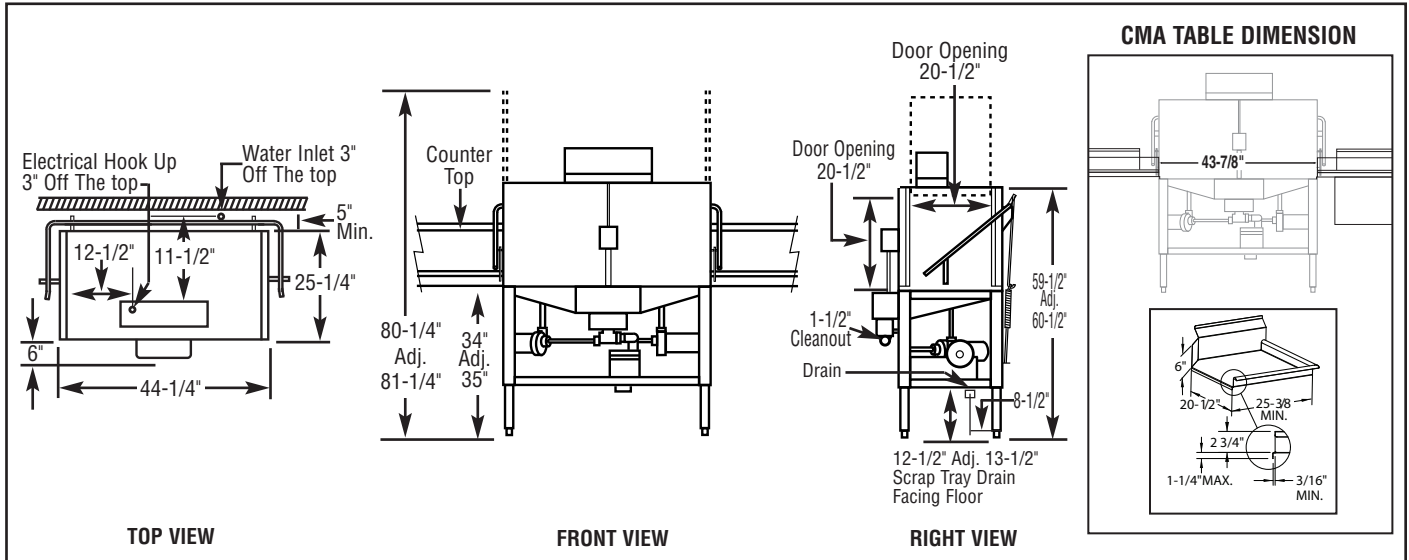

**Specifications:**

MODEL B ENERGY SAVER		USA	METRIC	WASH PUMP MOTORS HP		USA	METRIC
<b>OPERATING CAPACITY</b>				1			1
RACKS PER HOUR (NSF RATED)		80	80	<b>DIMENSIONS</b>			
<b>OPERATING CYCLE</b>				DEPTH	25-1/4"		(64cm)
WASH TIME-SEC		45	45	WIDTH	44-1/4"		(112cm)
RINSE TIME-SEC		30	30	HEIGHT	59-1/2"-60-1/2"		(151.1cm-153.7cm)
DWELL TIME-SEC		15	15	STANDARD TABLE HEIGHT	34"		(86cm)
TOTAL CYCLE TIME		90	90	MAXIMUM CLEARANCE FOR DISHES	20-1/2"		(52cm)
<b>WASH TANK CAPACITY MIN.</b>		1.92 GAL.	(7.27 L)	<b>STANDARD DISHRACK DIMENSIONS</b>	19-3/4"X19-3/4"		(50X50cm)
<b>OPERATING TEMPERATURE</b>				<b>ELECTRICAL RATING</b>	<b>VOLTS</b>		<b>AMPS</b>
REQUIRED		120°F	(49°C)		115		30
RECOMMENDED		140°F	(60°C)	<b>SHIPPING WEIGHT APPROXIMATE</b>		352#	(160kg)
<b>WATER CONSUMPTION</b>							
PER RACK		.96 GAL.	(3.63 L)				
PER HOUR		76.8 GPH	(290.7 LPH)				
<b>WATER REQUIREMENTS</b>							
WATER INLET		3/4"	(1.9cm)				
DRAIN-I.P.S.		2"	(5.1cm)				

**Summary Specifications: Model B Energy Saver**

CMA Energy Mizer model B Energy Saver low temperature, chemical sanitizing commercial dishwasher meets NSF, UL and ETL sanitation and construction standards WITHOUT the use of BOOSTER or TANK HEATERS. The model B Energy Saver meets Energy Star rating's and uses as little as .96 gallons of water per rack. The model B Energy Saver is constructed entirely of stainless steel. Each unit automatically washes, rinses and sanitizes food service utensils in standard 19-3/4" x 19-3/4" racks. Unit comes standard with upper and lower stainless steel wash arms. The model B Energy Saver incorporates a pump purging system that improves results by eliminating soil and chemical carryover during rinse cycle. **Note: This machine does not have built-in heaters, therefore produces no steam.**





## CMA TEMP-SURE™

Hot Water Assurance System  
For Dump And Fill Style  
Dishwashers

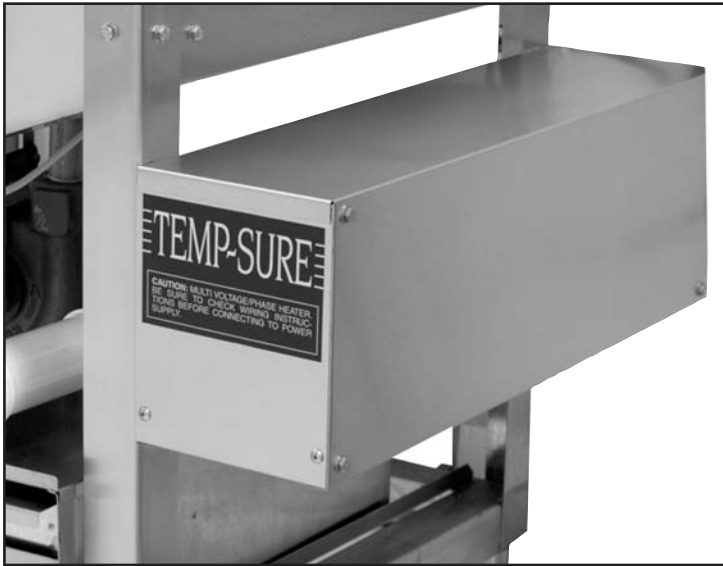

### FEATURES:

- Specifically designed to maintain proper rinse temperatures in dump and fill style dishwasher.
- 12kW industrial heater is proven to be more durable than commercial style heater.
- Fast recovery, 40° rise in 90 seconds.
- Available 208/240 volt, single or three phase for flexible applications.
- Universal mounting system fits all single tank CMA models and most competitor model dishwashers.
- Free standing units also available.

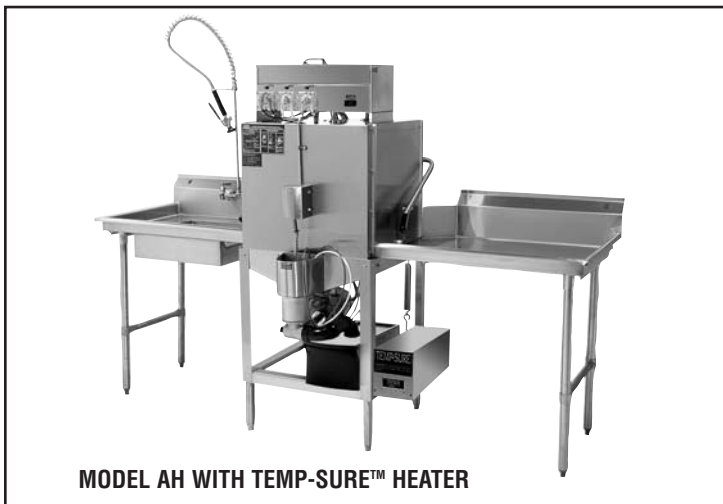

MODEL AH WITH TEMP-SURE™ HEATER



Temp-Sure™ shown as a free standing unit.

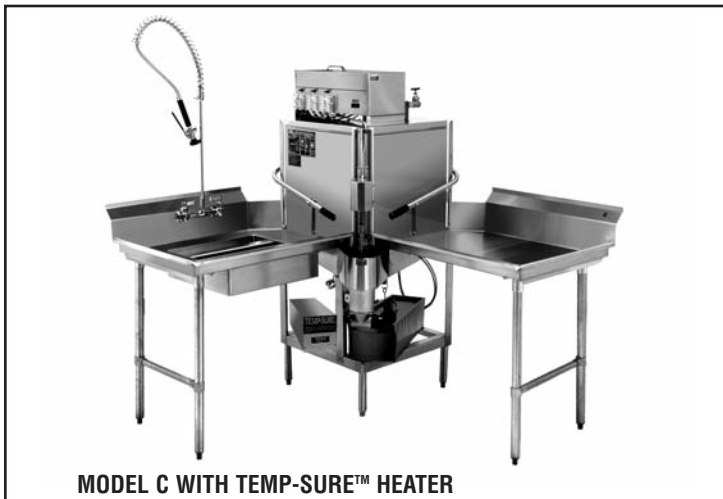

MODEL C WITH TEMP-SURE™ HEATER



# CMA TEMP-SURE™

Hot Water Assurance System  
For Dump And Fill Style  
Dishwashers

**WARNING:** Plumbing connections must be made by a qualified service company who will comply with all available Federal, State, and Local Health, Plumbing and Safety codes.

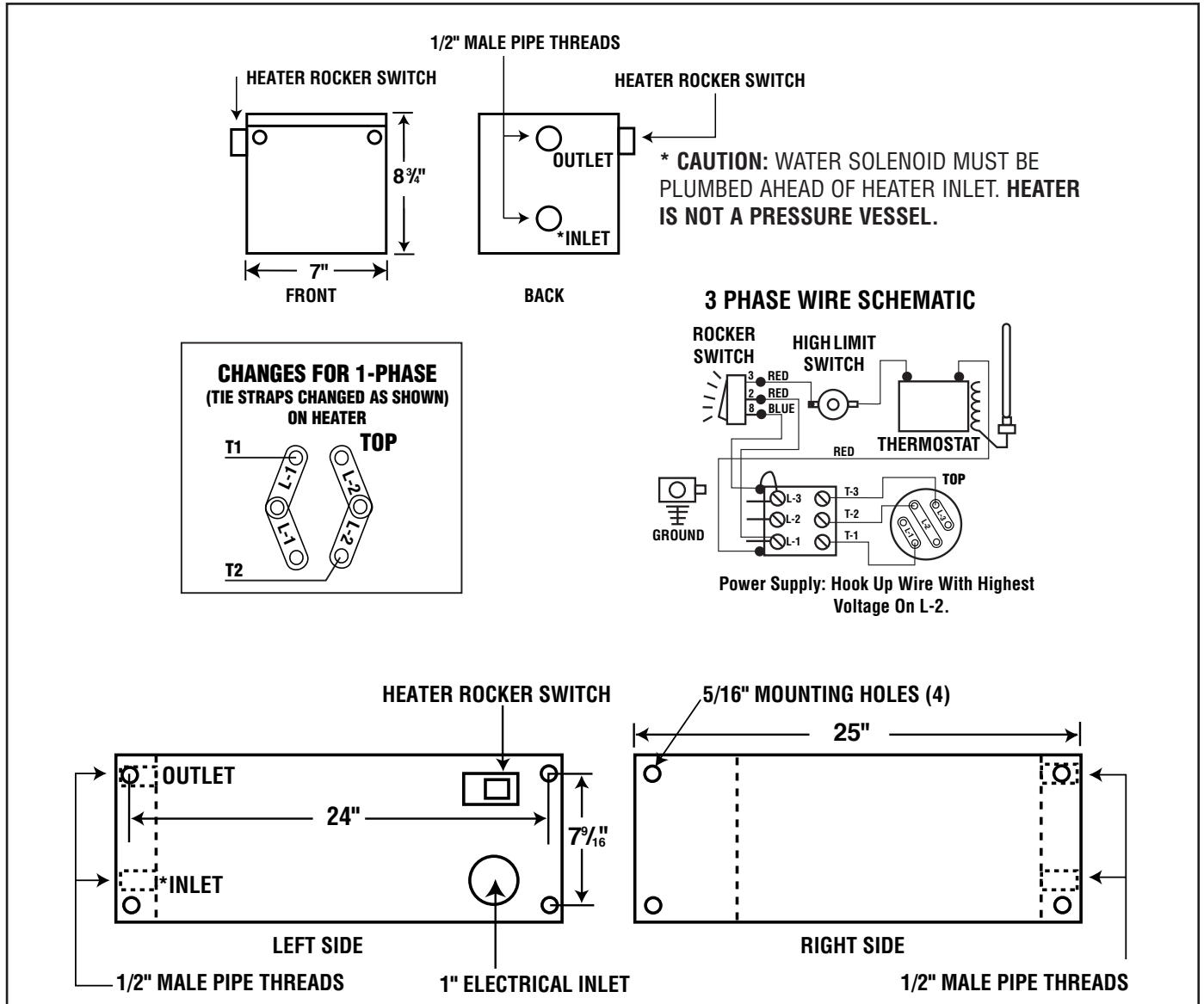

The CMA-Temp-Sure™ option assures a continuous supply of 140°F hot water resulting in excellent dishmachine performance. The heater is custom-designed for fill and dump CMA single tank dishwashers as a factory added option or an infield add-on. The heater will also fit most competitor's single tank dishmachines.

## SPECIFICATIONS:

MODEL: CMA TEMP-SURE™	USA	METRIC
MIN. INCOMING WATER TEMP.	100°F	(55°C)
RISE	40°F	(22°C)
AVAILABLE HOT WATER	90 GPH	(341LPH)
HEATER TANK CAPACITY	2.6 GAL	(9.8L)
<b>ELECTRICAL RATING</b>	<b>VOLTS</b>	<b>PHASE</b>
	208	1
	240	1
	208	3
	240	3
		<b>AMPS</b>
		44
		51
		26
		30

