



MODEL GL-X

**FEATURES:**

- **ENERGY STAR® Approved**
- 30 racks per hour.
- Economical to operate. Uses only 1.7 gallons of water per cycle.
- All stainless steel construction assures long life and years of trouble free operation.
- Unique spray arm system features upper and lower stainless steel wash arms with reinforced end caps.
- Built-in chemical pumps and delimiting system assures proper chemical usage.
- Convenient to service "Works-in-a-drawer". All electrical components are attached to a sliding drawer for easy access and service.
- Instant start for simple operation.
- Built-in Hot Water Assurance System guarantees hot water every cycle.
- Pumped drain allows for flexible installations. No floor drain required.
- Wash tank sustainer heater keeps water at proper temperature between loads.

**Available Options**

- Sanitizer Alarm

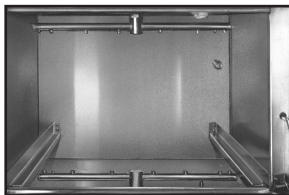

Upper and lower rotating wash arms guarantee excellent results.



Uses standard 19-3/4" X 19-3/4" racks. Large 11-1/4" glass clearance.

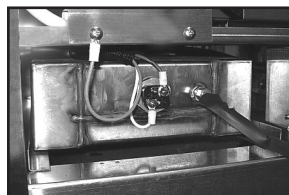

"Built in" Hot Water Assurance System provides hot water every cycle.



"Works-in-a-drawer". All electrical components are attached to a sliding drawer for easy access and service.





**WARNING:** Plumbing connections must be made by a qualified service company who will comply with all available Federal, State, and Local Health, Plumbing and Safety codes.

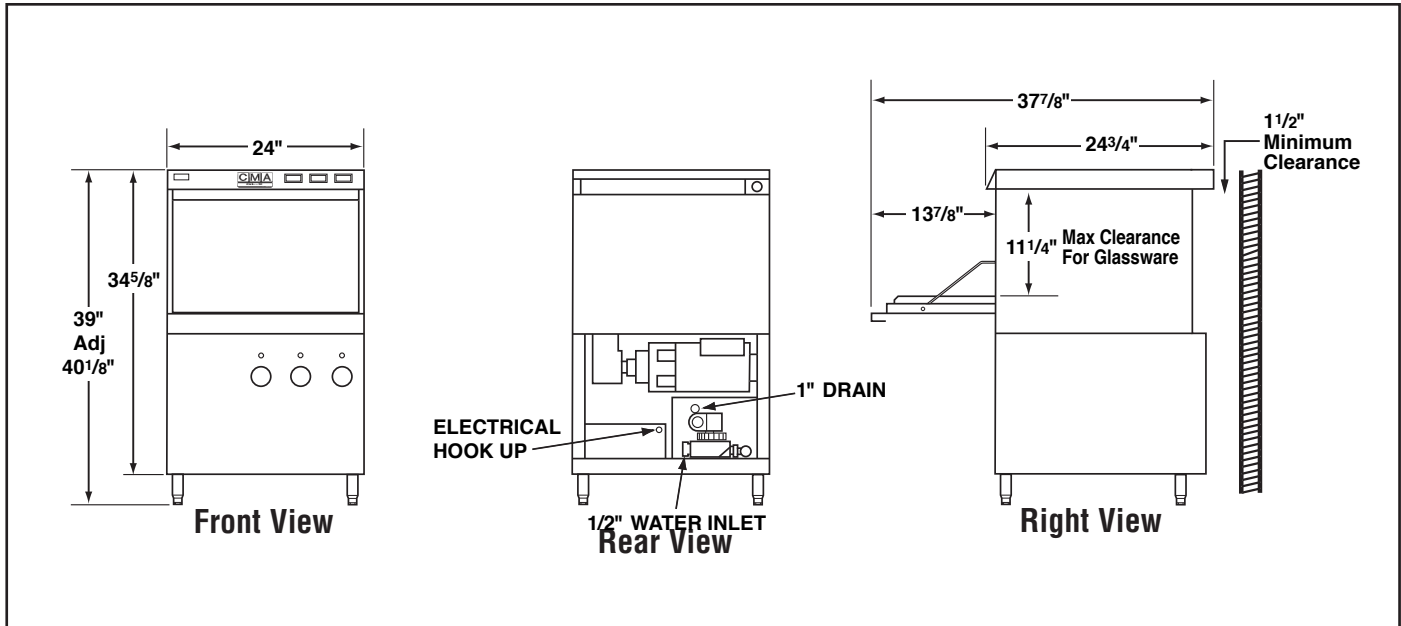

**Specifications:**

MODEL GL-X	USA	METRIC	USA	METRIC
<b>OPERATING CAPACITY</b>				
RACKS PER HOUR	30	30		
<b>OPERATING CYCLE</b>				
WASH TIME-SEC	57	57		
RINSE TIME-SEC	48	48		
DWELL/TIME-SEC	15	15		
TOTAL CYCLE TIME	120	120		
WASH TANK CAPACITY	1.7 GAL.	(6.45 L)		
WASH PUMP CAPACITY	35 GPM	(132 LPM)		
<b>MINIMUM TEMPERATURE REQUIRED</b>				
WASH TEMP.	120°F	(50°C)		
<b>WATER CONSUMPTION</b>				
PER RACK	1.7 GAL.	(6.45 L)		
PER HOUR	40.8 GPH	(154.4 LPH)		
WATER INLET	1/2"	(1.27 cm)		
DRAIN	1"	(2.54cm)		
<b>WASH PUMP MOTOR HP</b>			1	1
<b>DIMENSIONS</b>				
DEPTH			24-3/4"	(63cm)
WIDTH			24"	(61cm)
HEIGHT			39"-40-1/8"	(99-102cm)
MAXIMUM CLEARANCE FOR GLASSWARE			11-1/4"	(28.57cm)
<b>STANDARD DISHRACK DIMENSIONS</b>			19-3/4"X19-3/4"	(50X50cm)
<b>ELECTRICAL RATING</b>			<b>VOLTS</b>	<b>AMPS</b>
			115	16
<b>SHIPPING WEIGHT APPROXIMATE</b>			244#	(110.6kg)

**Summary Specifications: Model GL-X**

The GL-X glasswasher is designed to produce sparkling clean glassware utilizing our unique Hot Water Assurance System. The GL-X is easy to use, fast and efficient, while conserving water, energy and chemicals. Built-in sustainer heater provides continuous 130°F hot water every cycle. The GL-X is constructed entirely of stainless steel and is equipped with an integrated chemical delivery system. The GL-X incorporates a pump purging system that improves results by eliminating soil and chemical carryover during rinse cycle.

